

# Unidad Didáctica



Guía Didáctica  
de Educación Vial para la  
Educación Infantil



GOBIERNO  
DE ESPAÑA

MINISTERIO  
DEL INTERIOR



Dirección General  
de Tráfico

# 1 Los trayectos "En busca del destino"

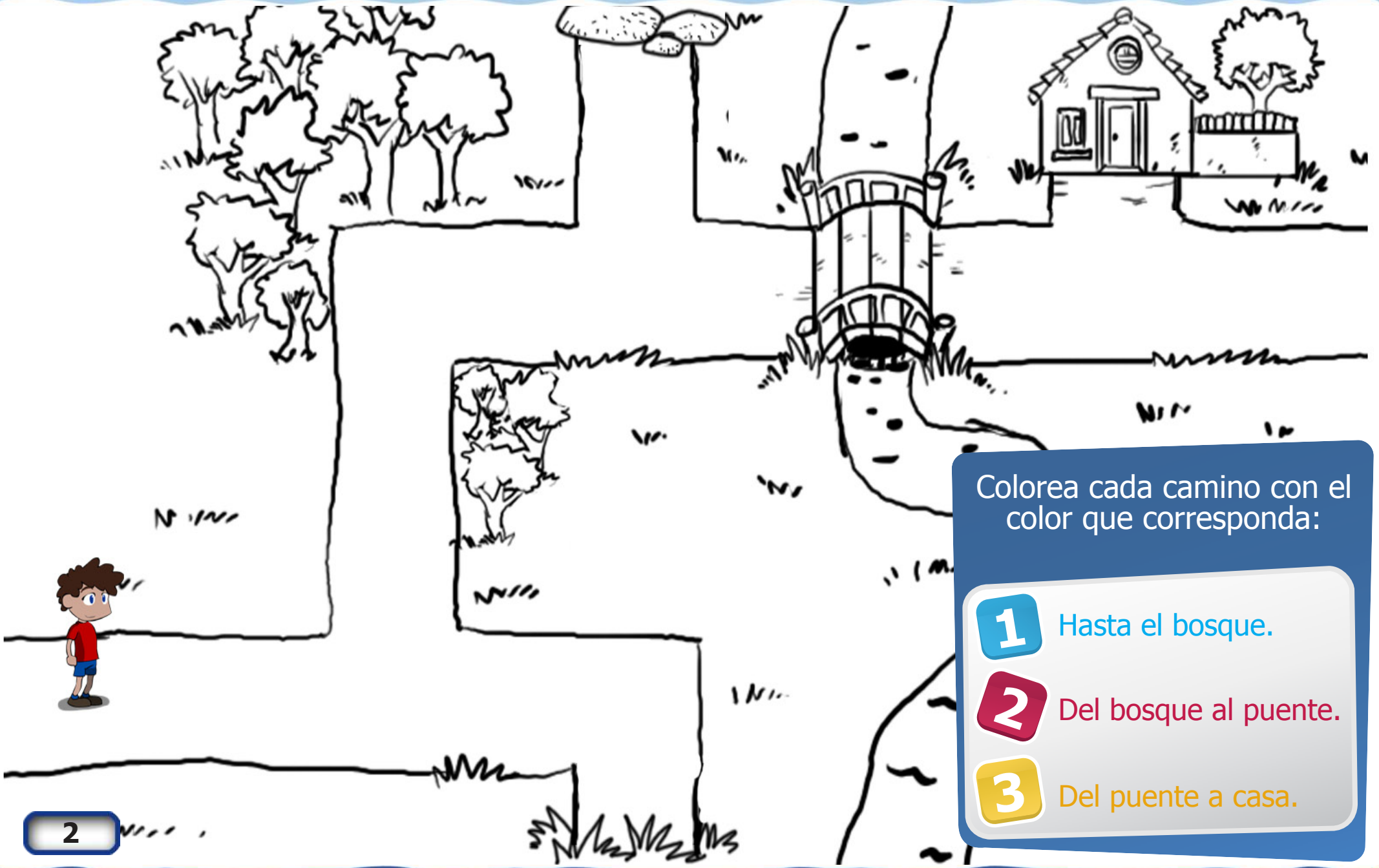

Colorea cada camino con el color que corresponda:

- 1 Hasta el bosque.
- 2 Del bosque al puente.
- 3 Del puente a casa.

# 1 Los trayectos "De camino al colegio"

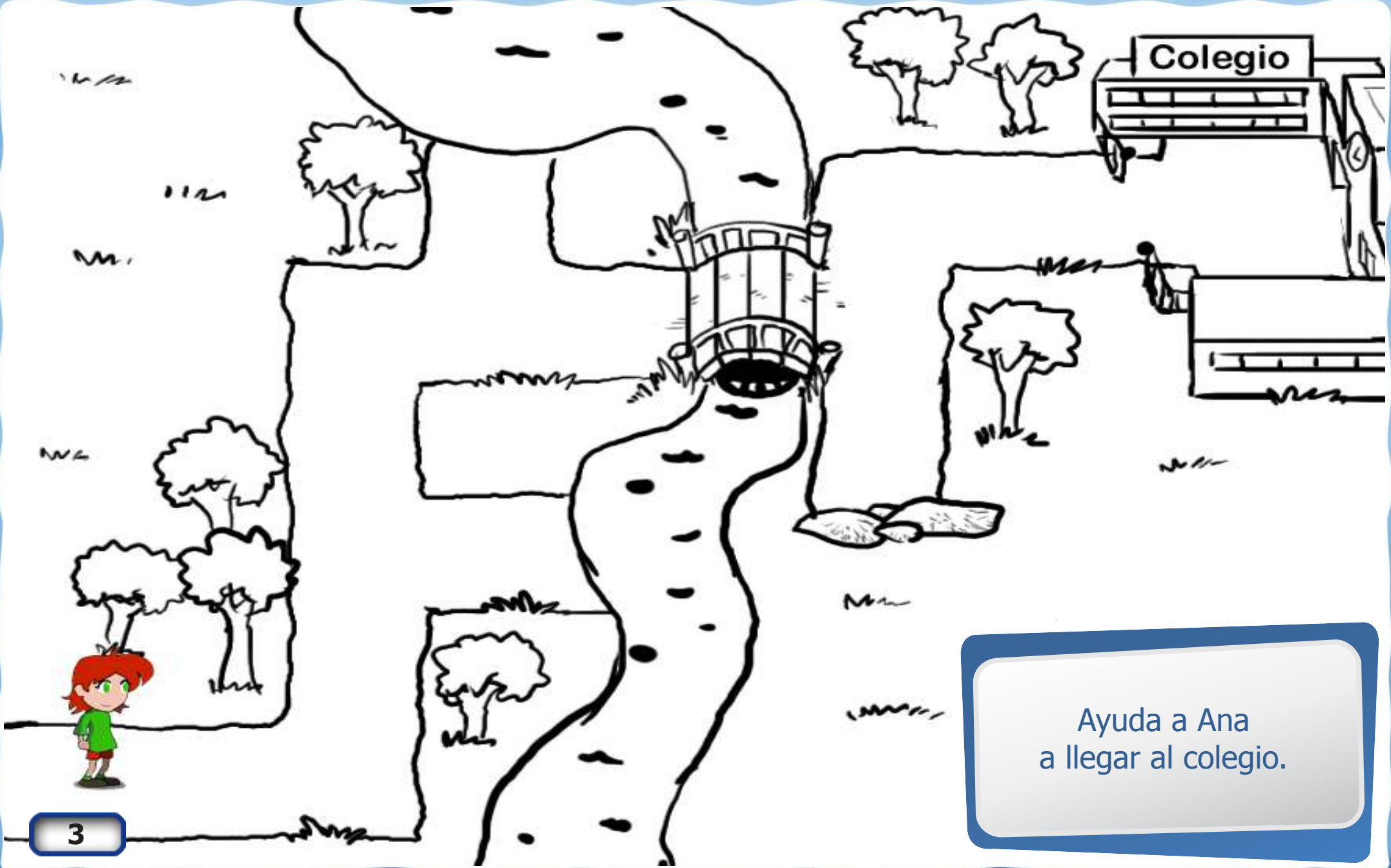

Ayuda a Ana  
a llegar al colegio.

# 1 Los trayectos "De camino al parque"



Ayuda a Tino  
a llegar al parque.

# 1 Los trayectos "De viaje en el coche"

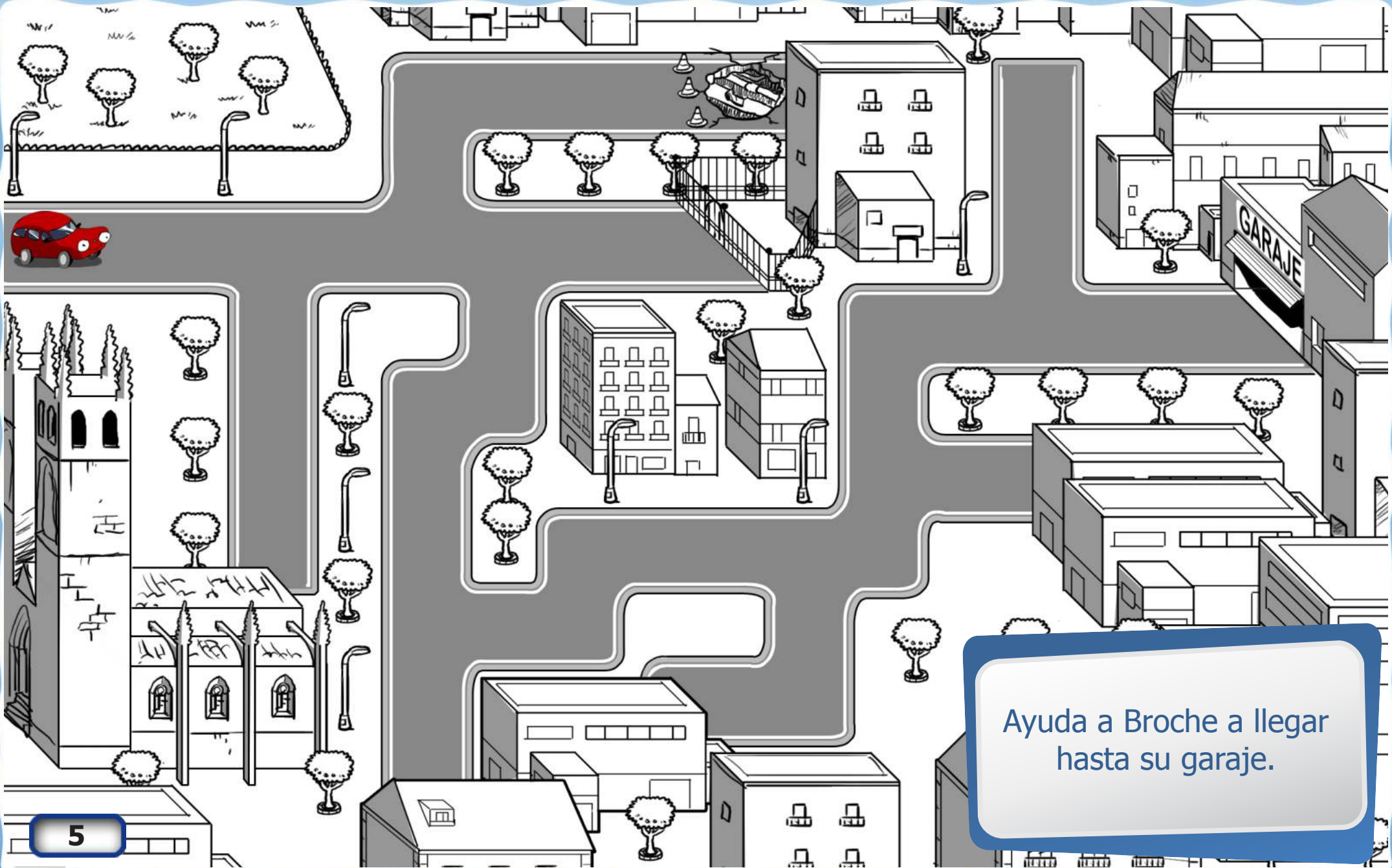

5

Ayuda a Broche a llegar hasta su garaje.

★ Coloca sobre el autobús las fotos y nombres de tus compañeros y compañeras.

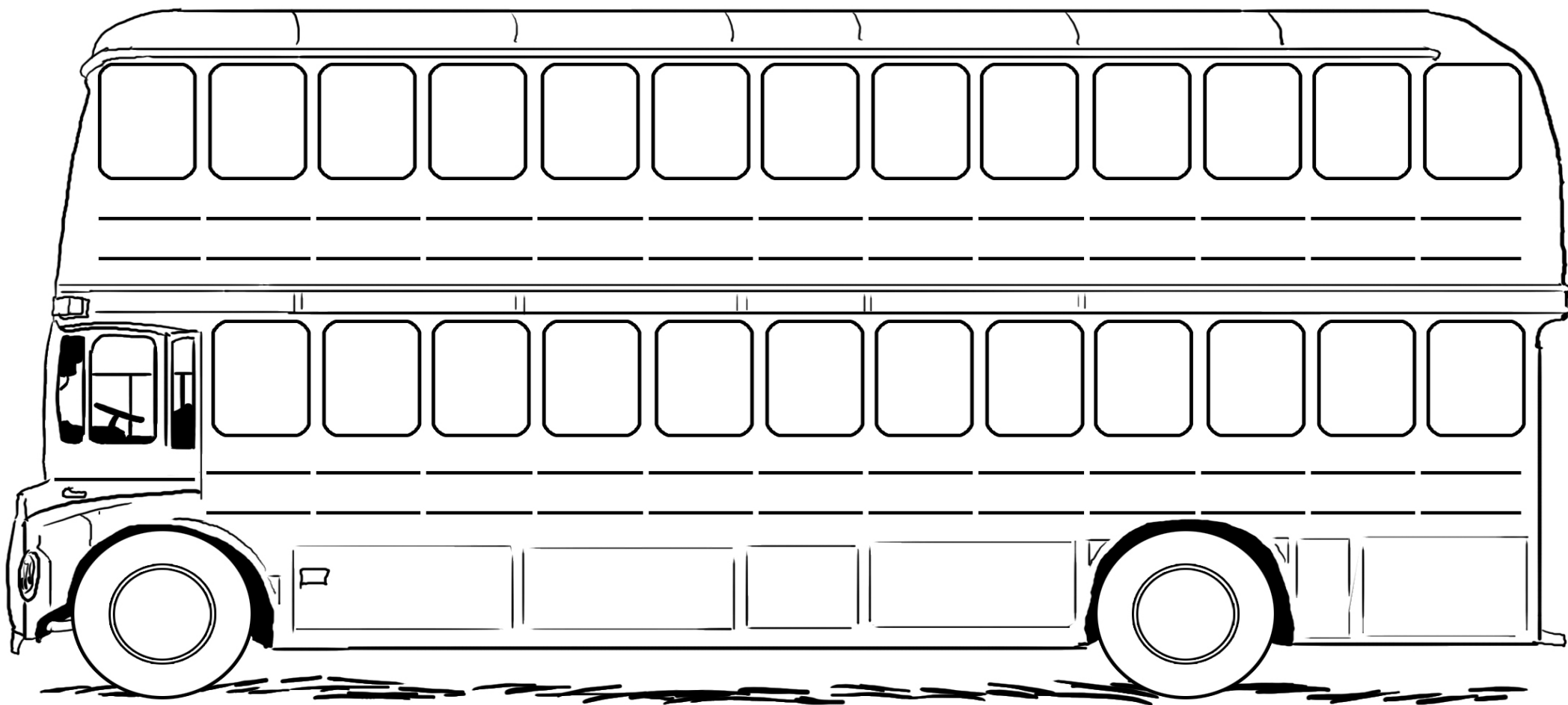

★ Coloca sobre cada ventana del colegio las fotos y el nombre de tus compañeros y compañeras.

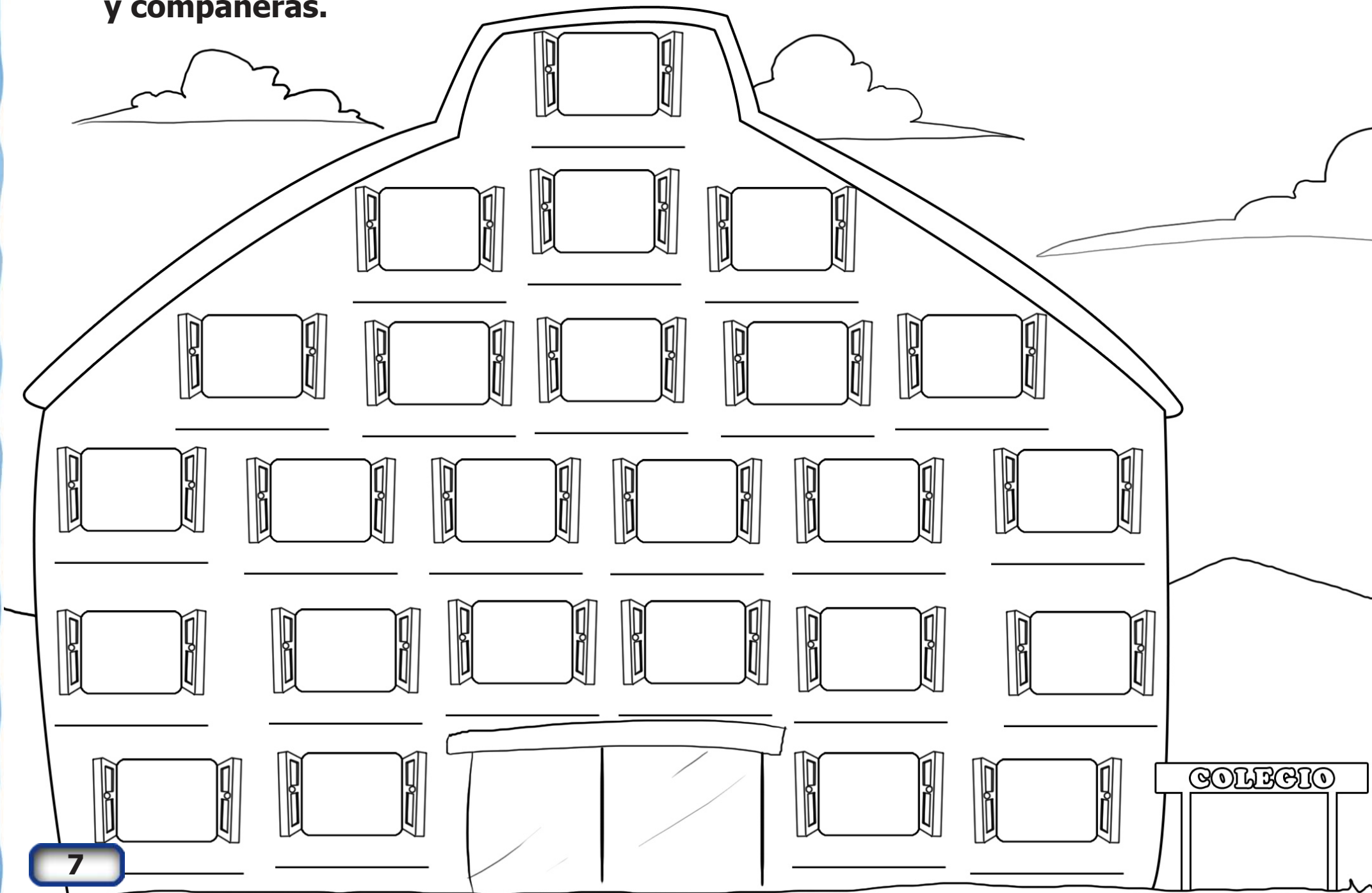



Recorta y colorea.





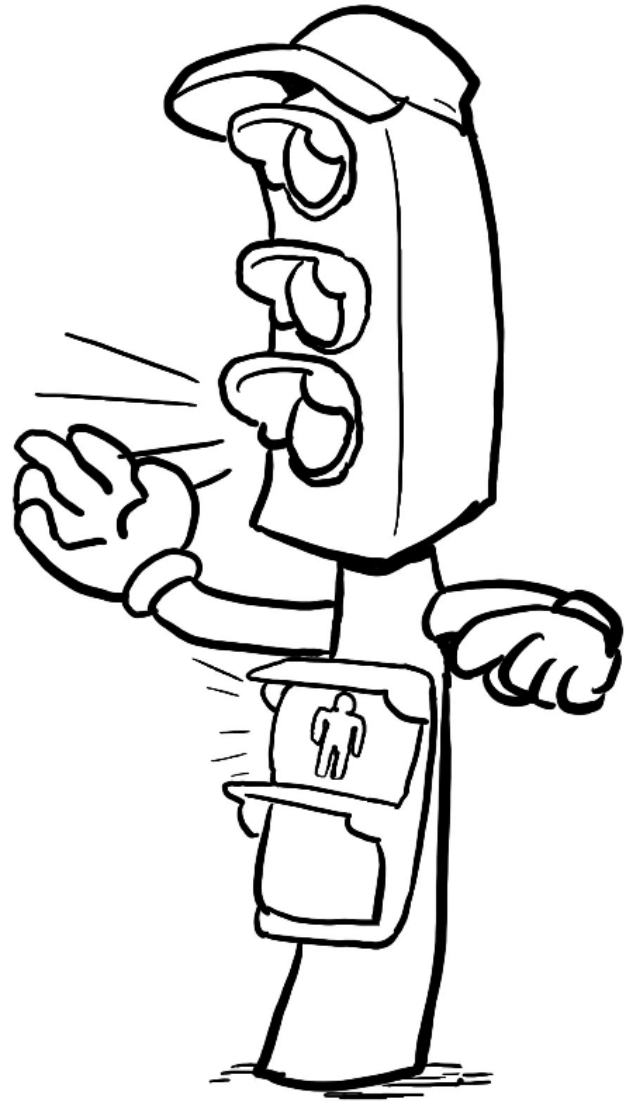
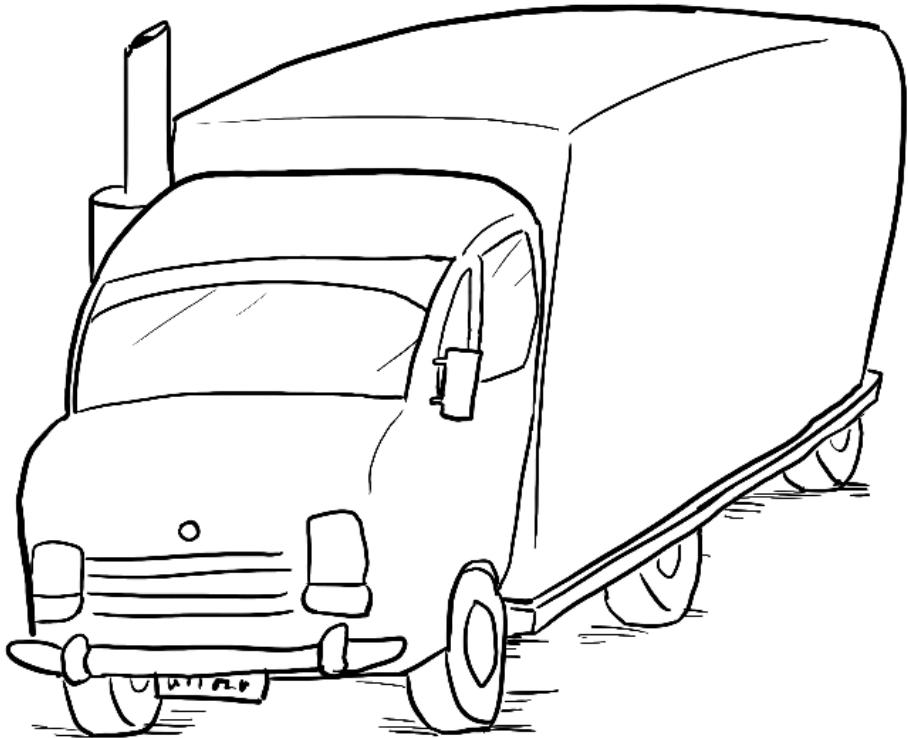

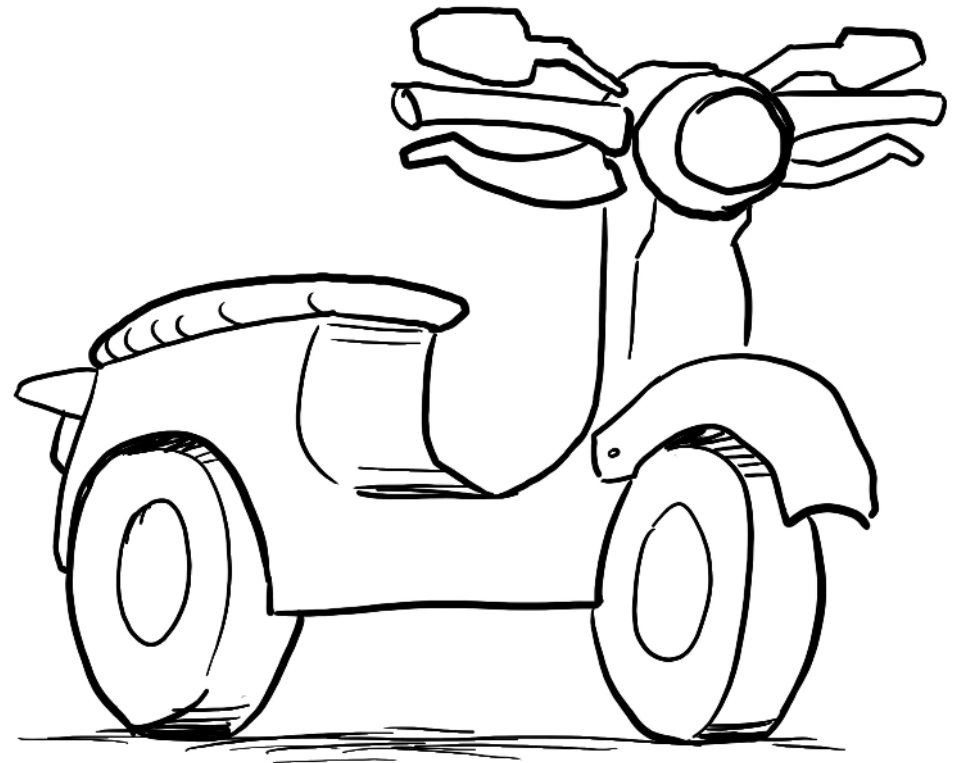
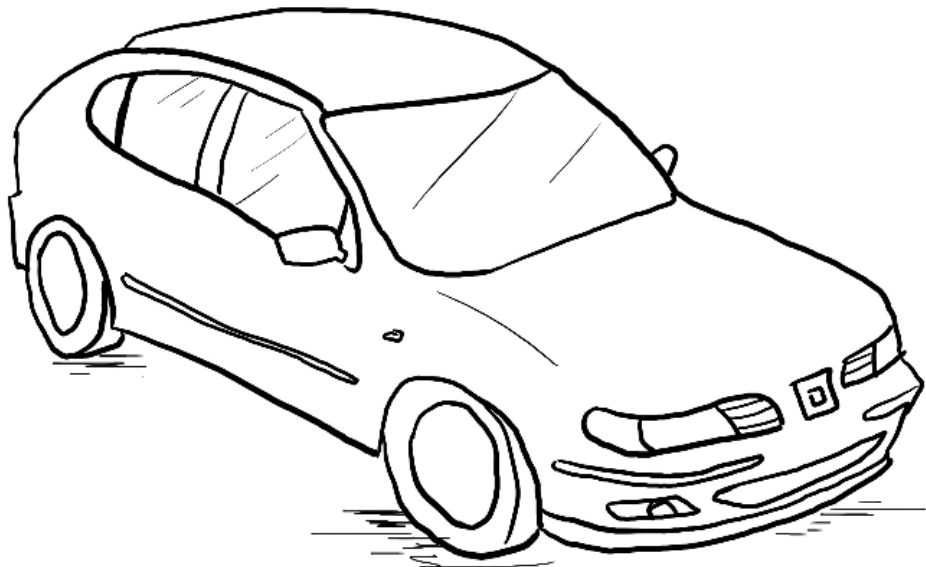

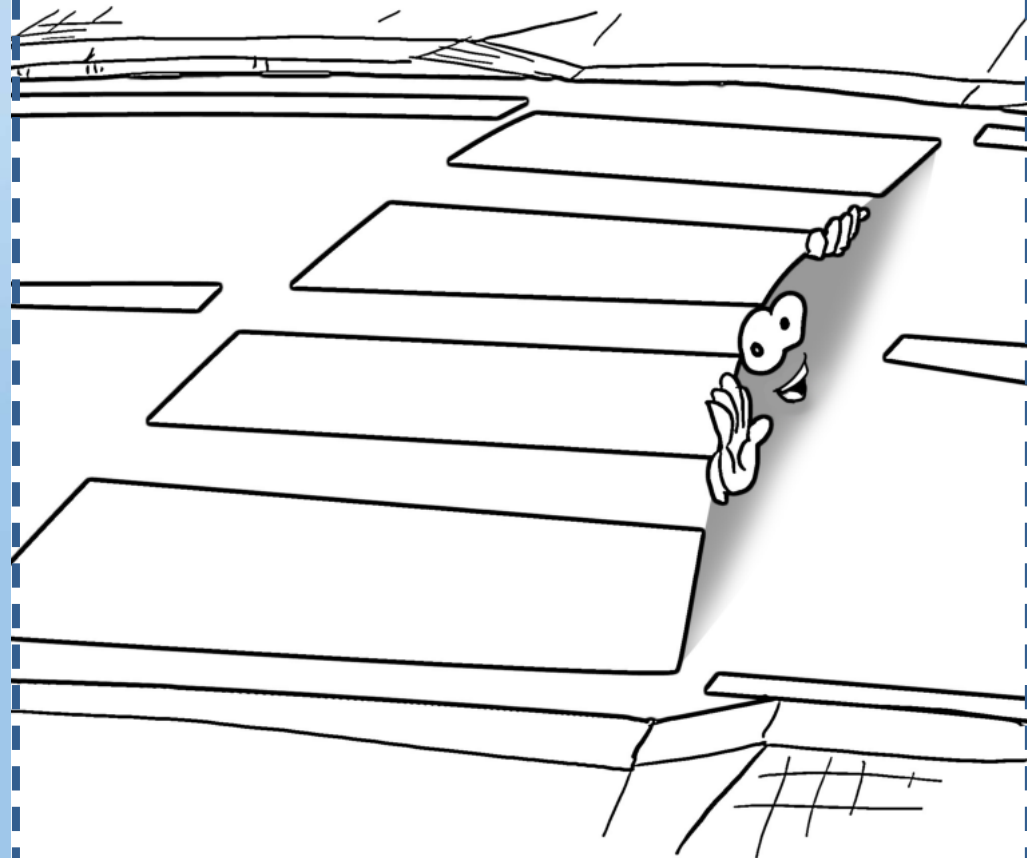
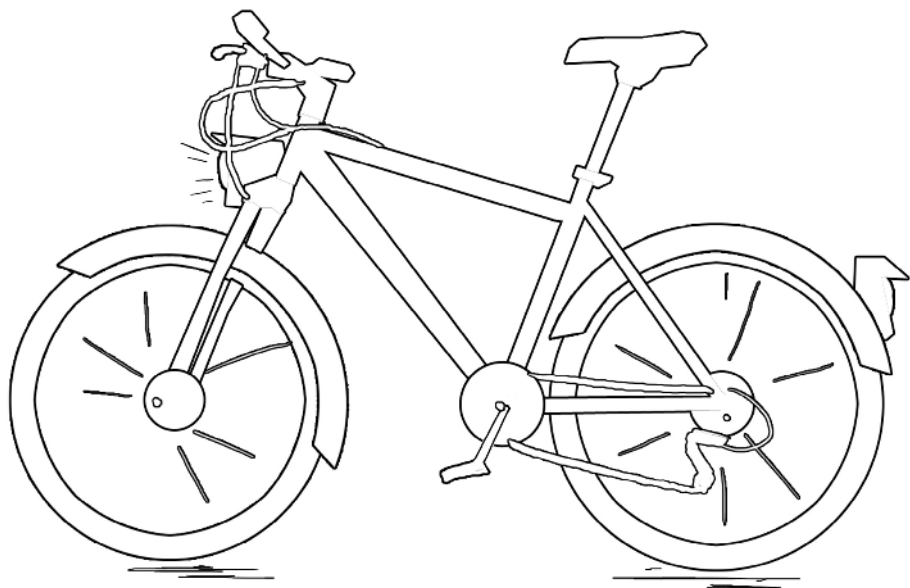



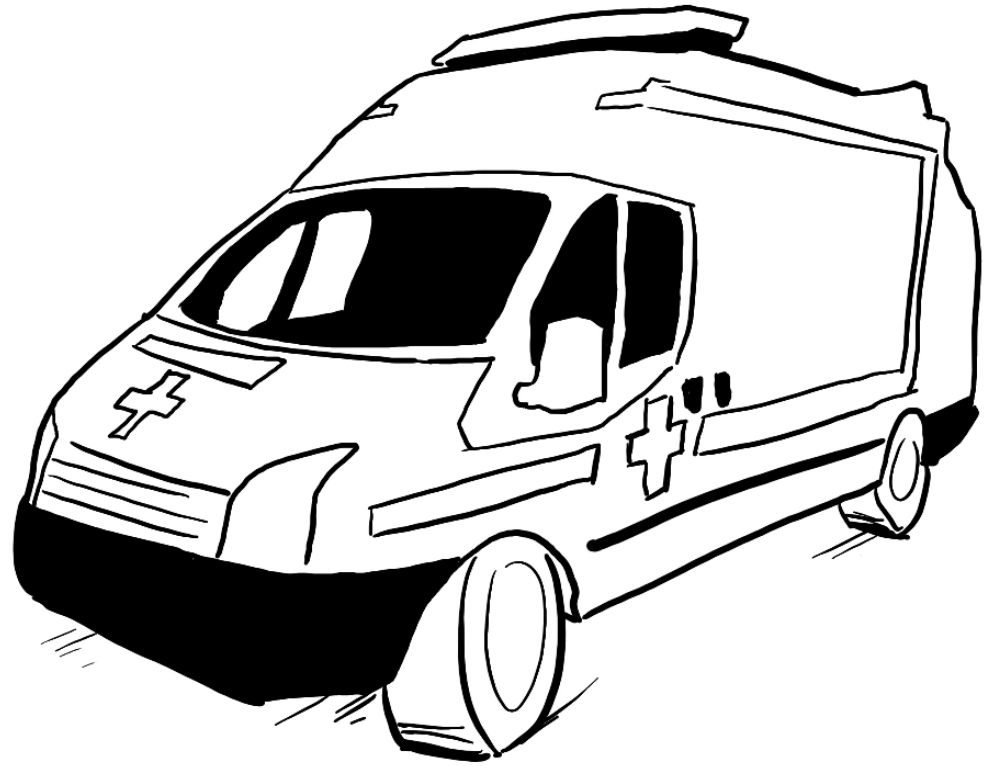

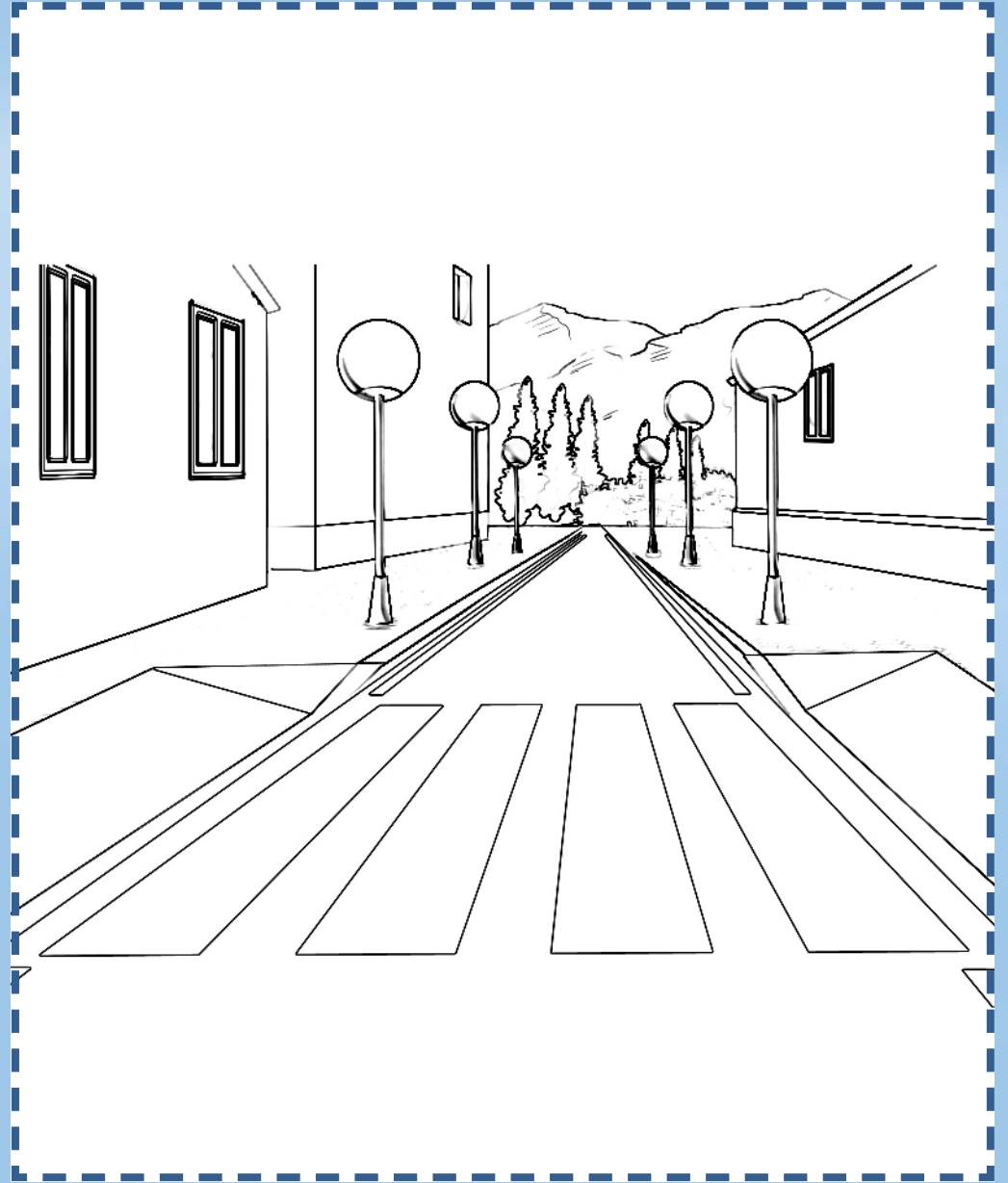

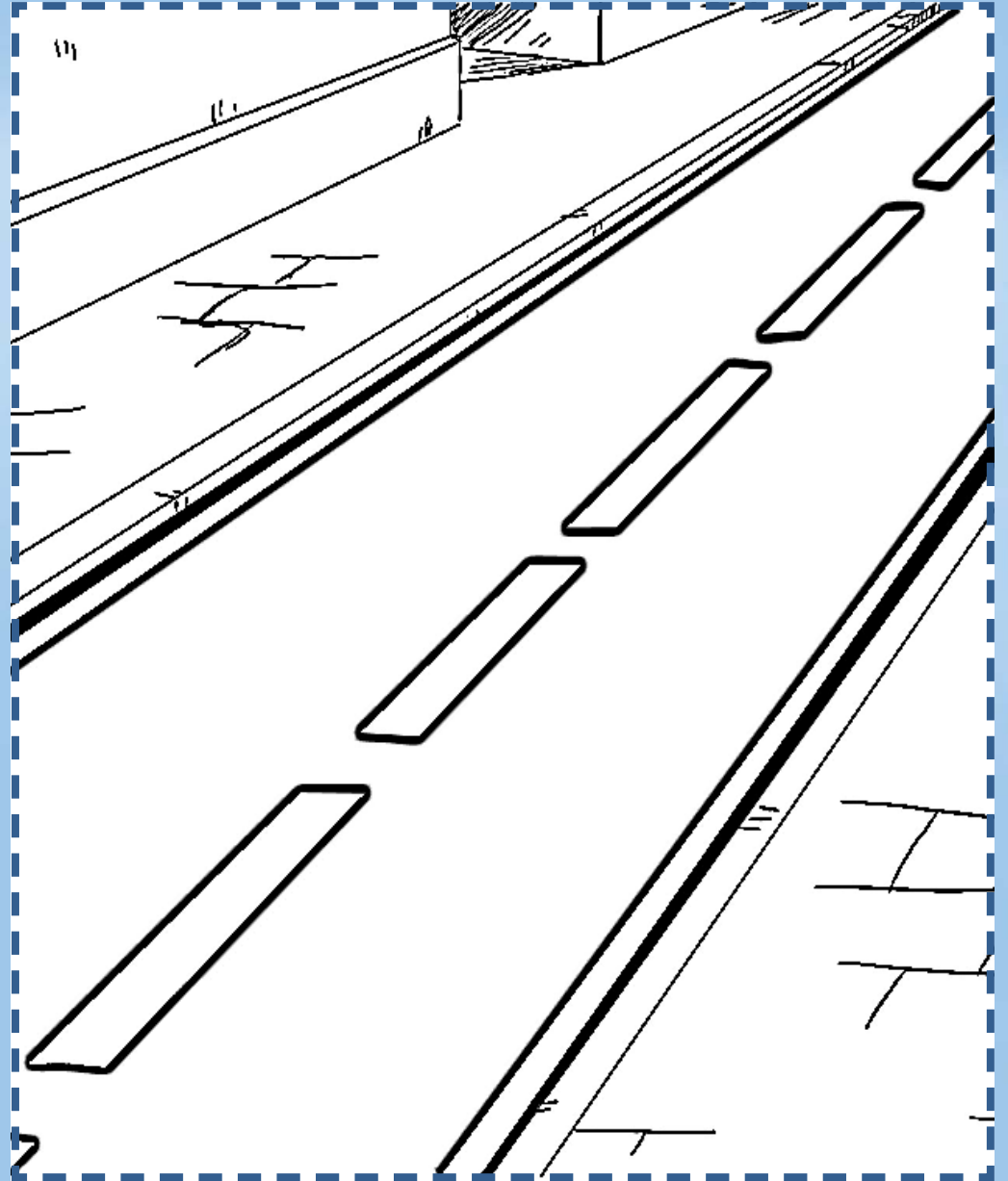
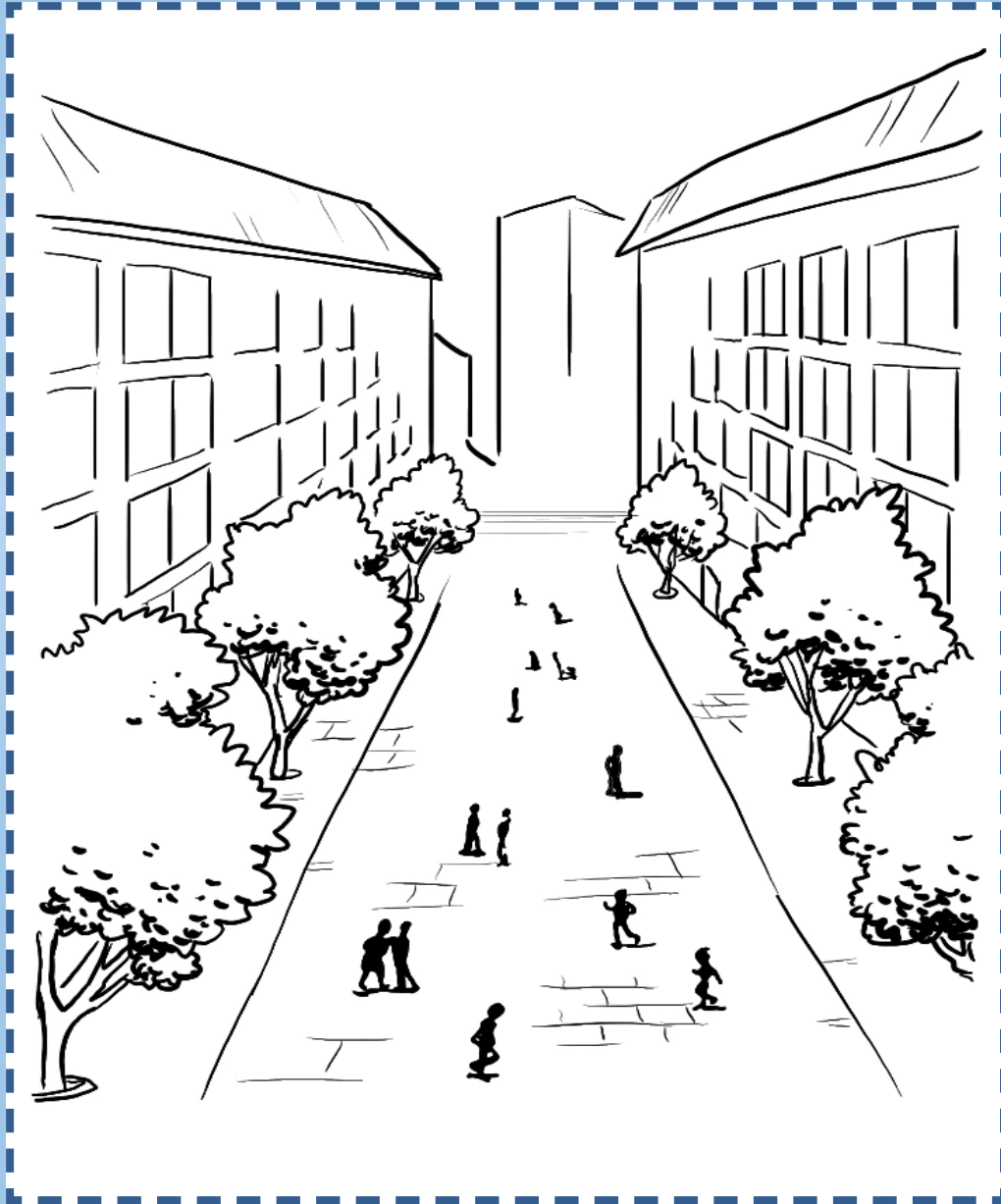

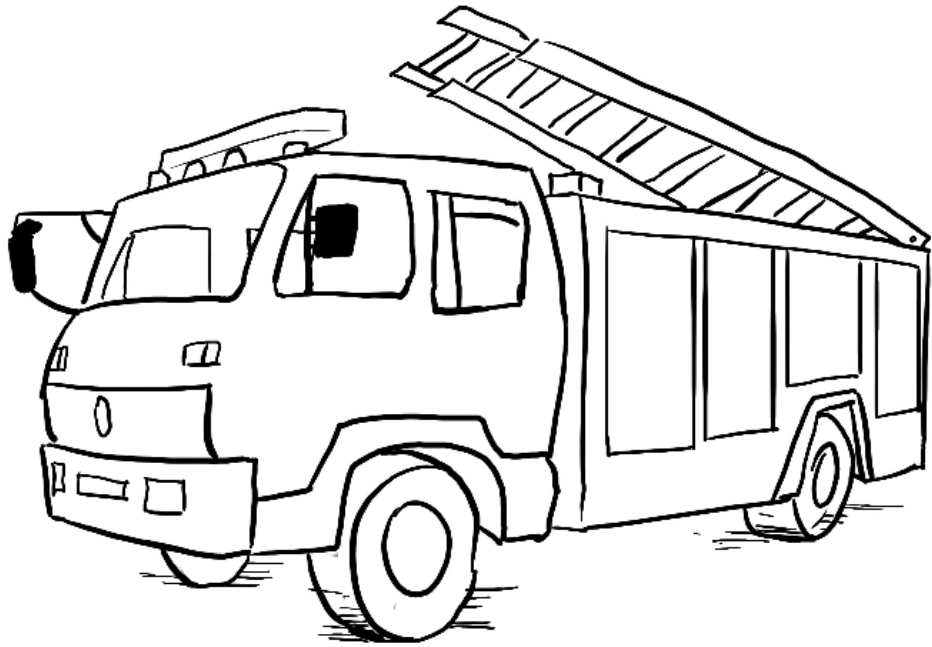



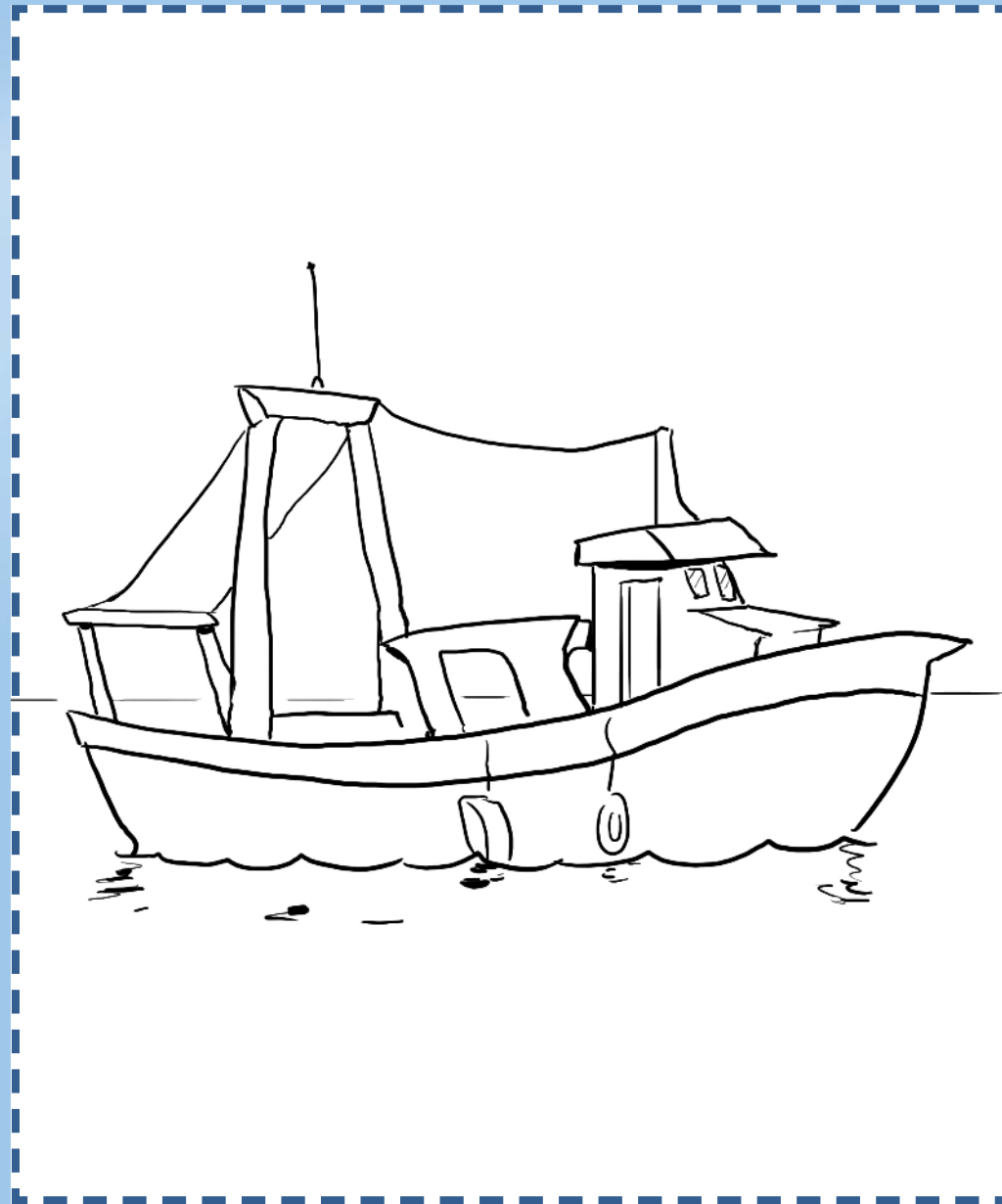
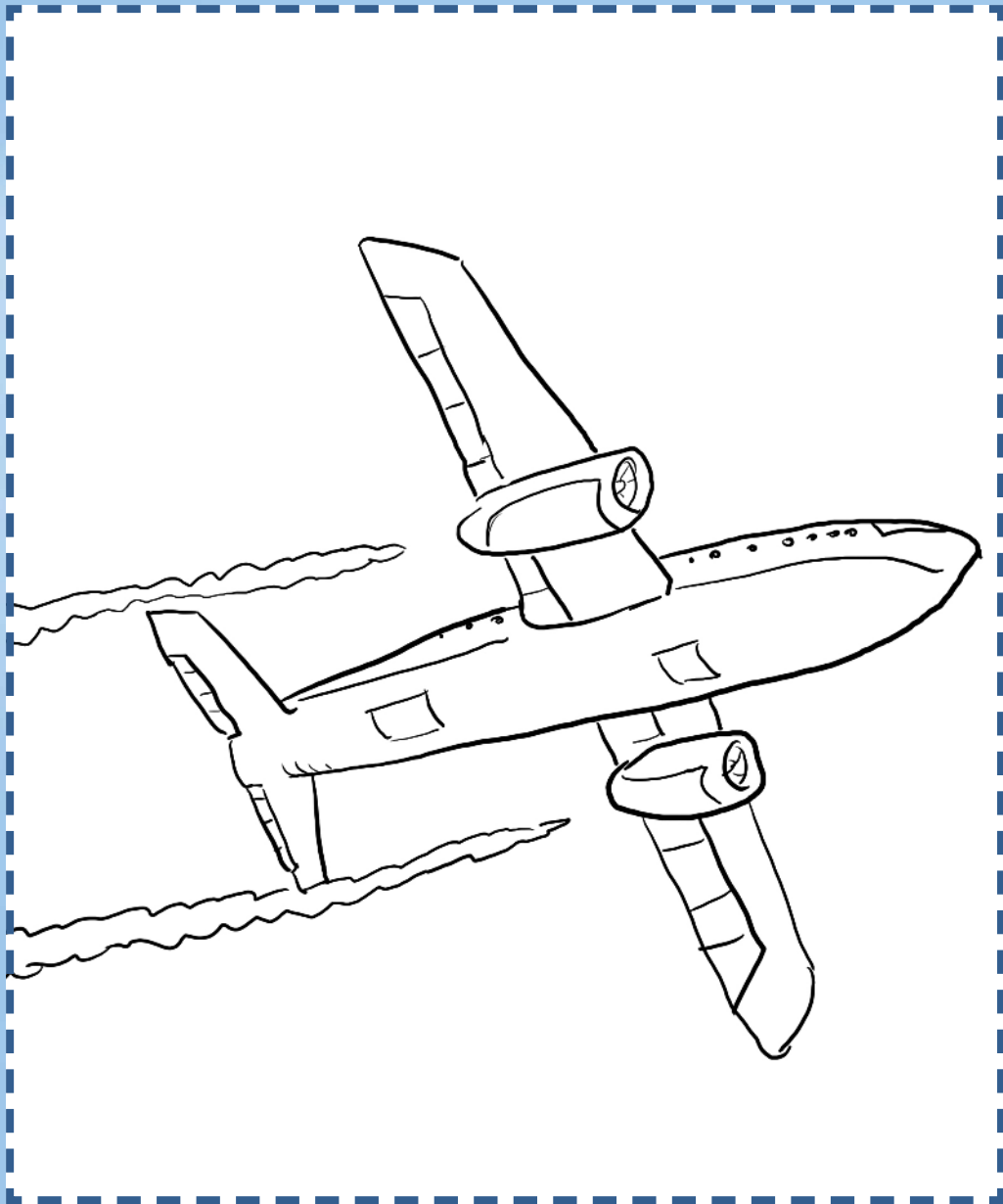

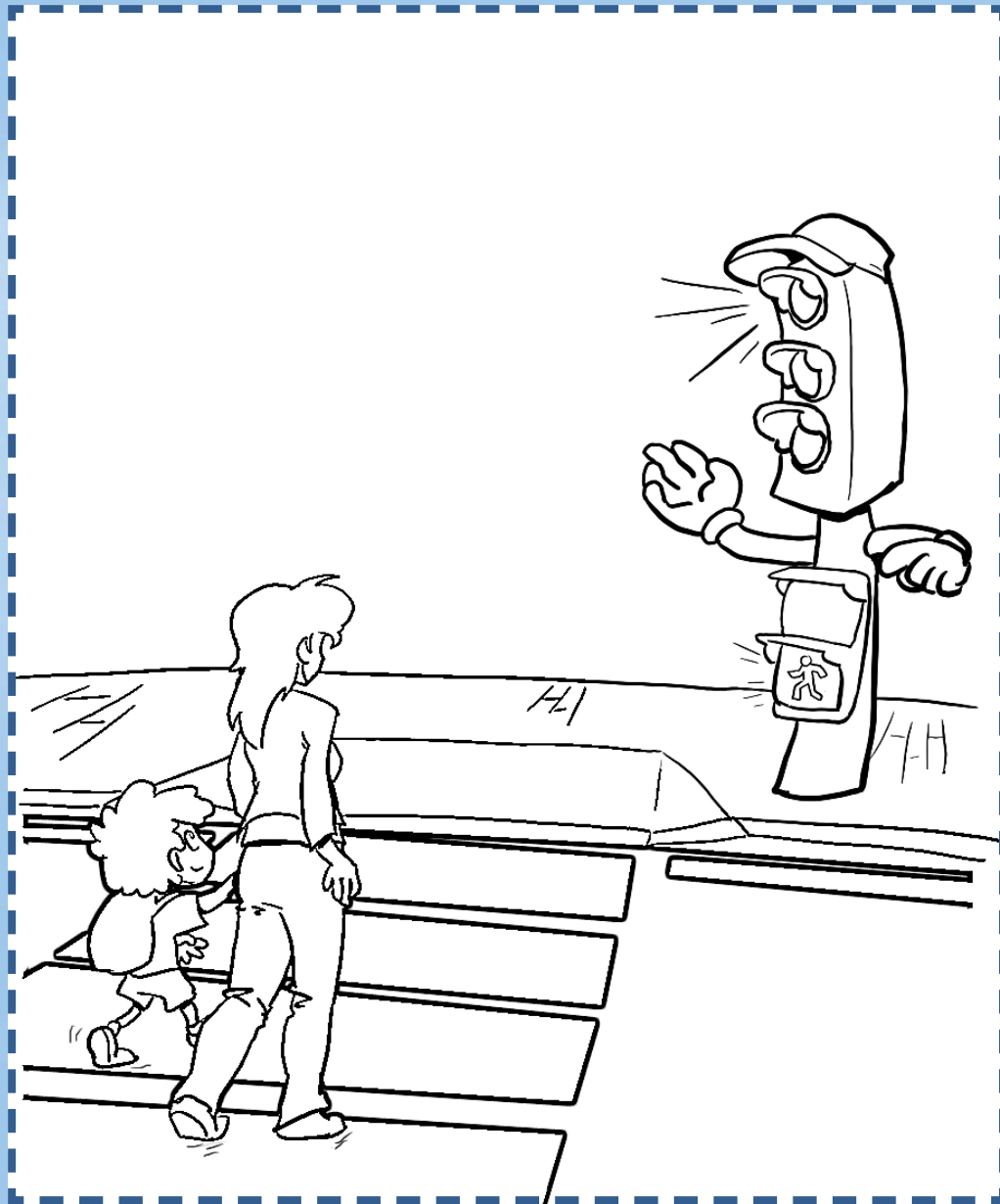

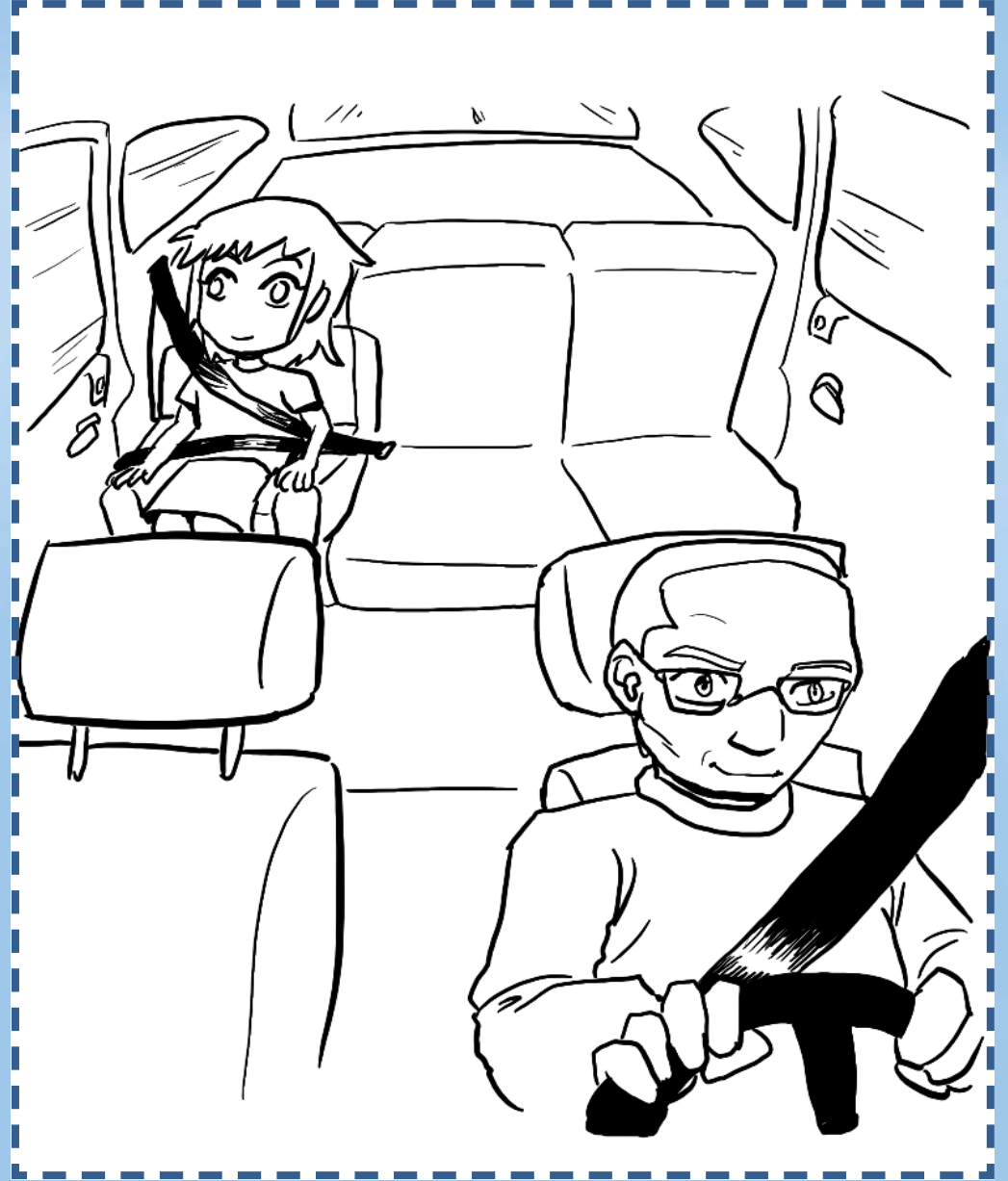
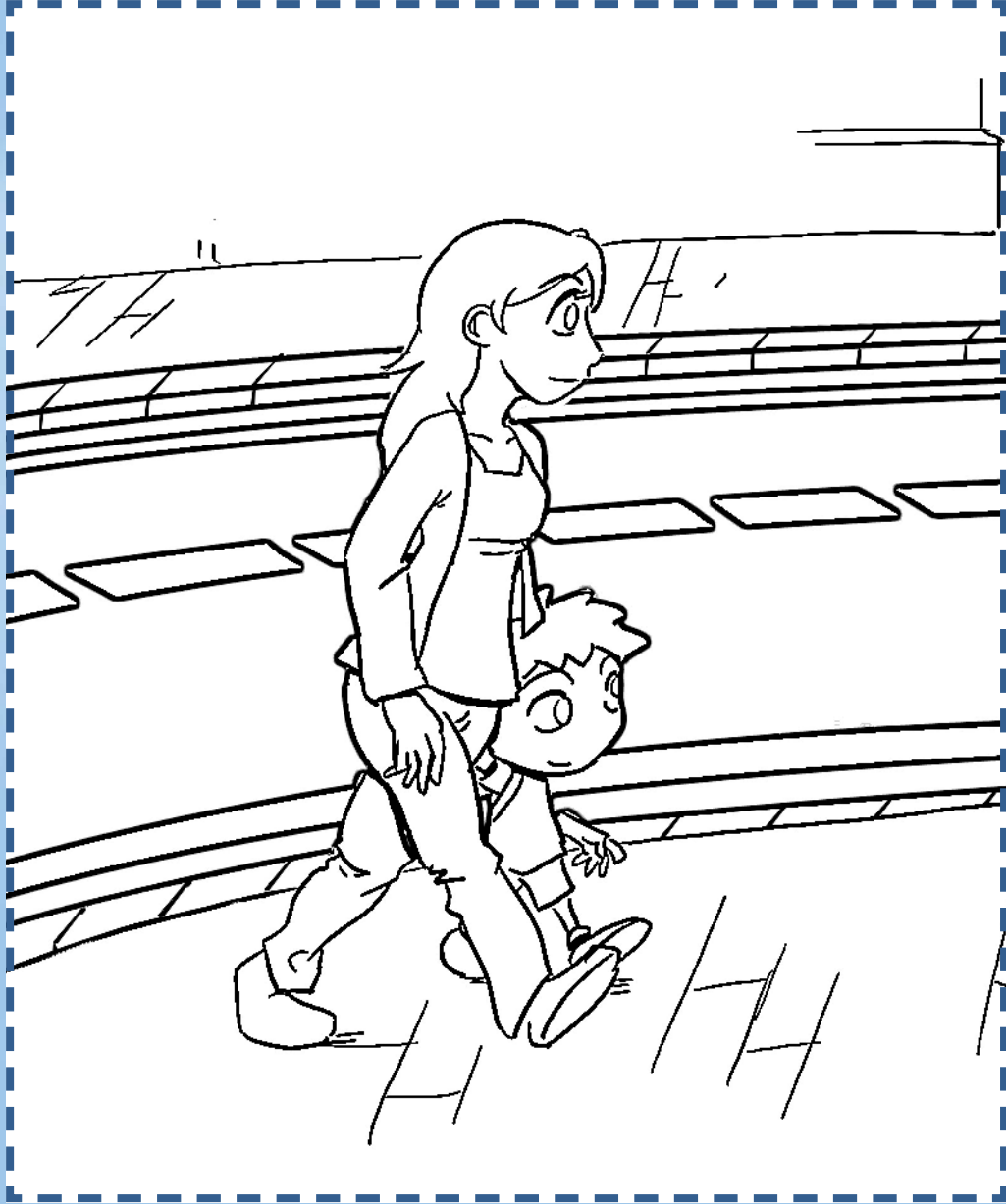

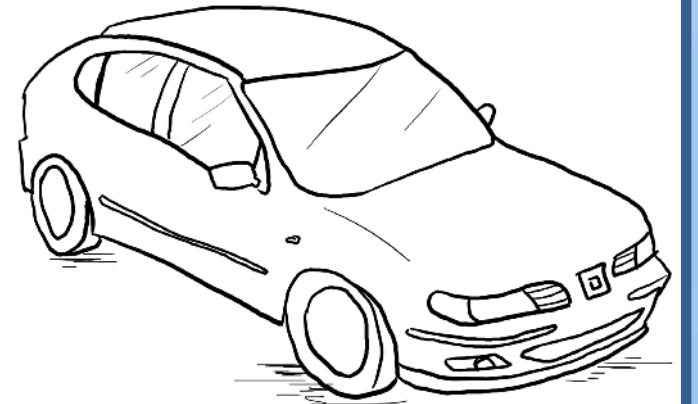
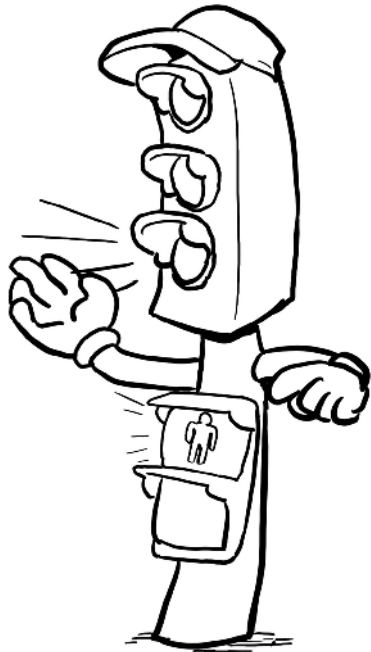
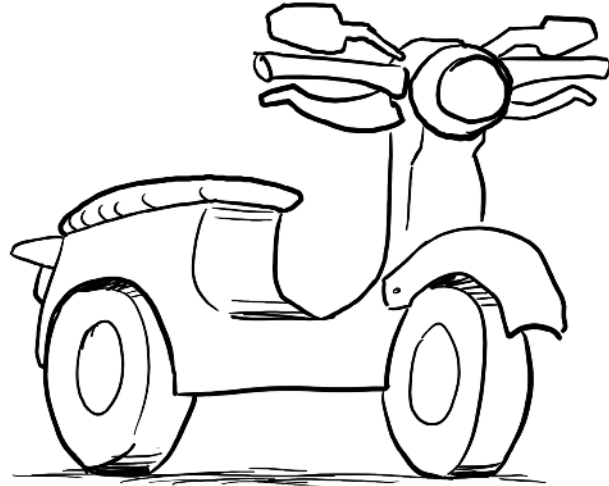

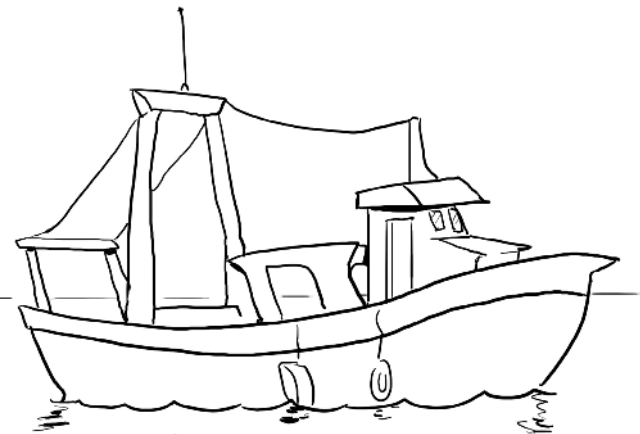
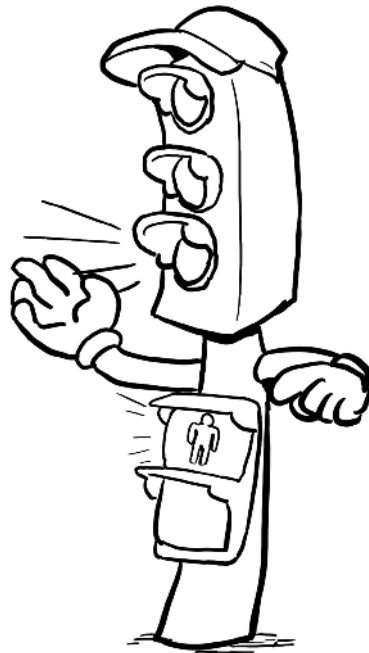
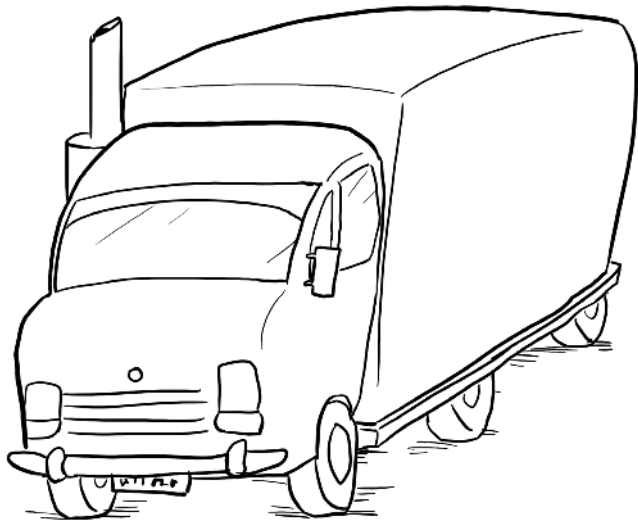
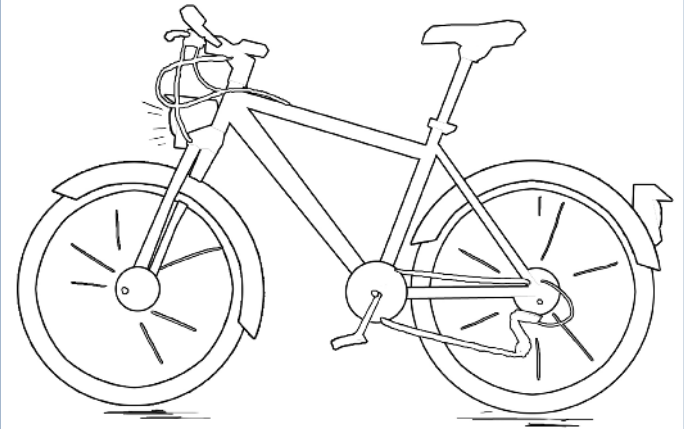
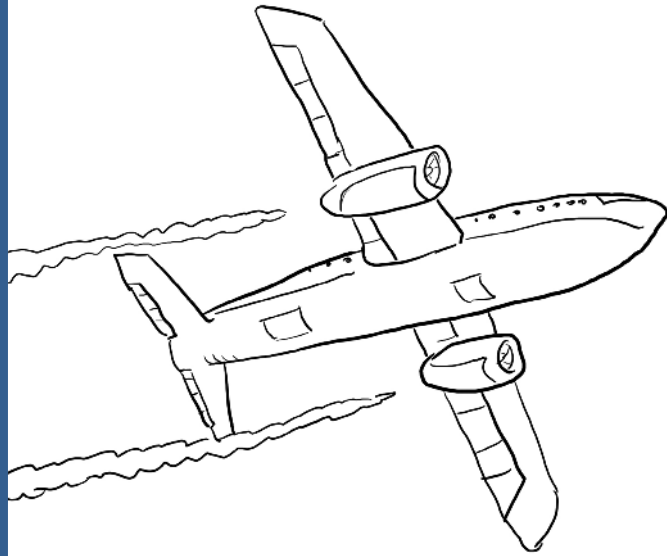

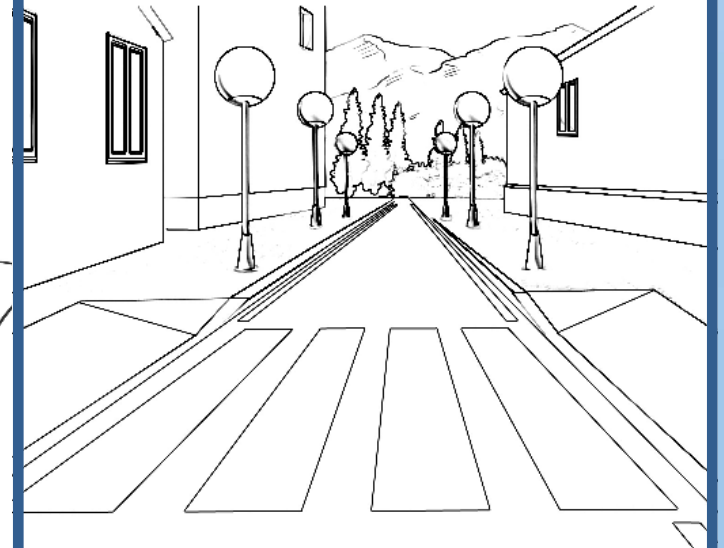
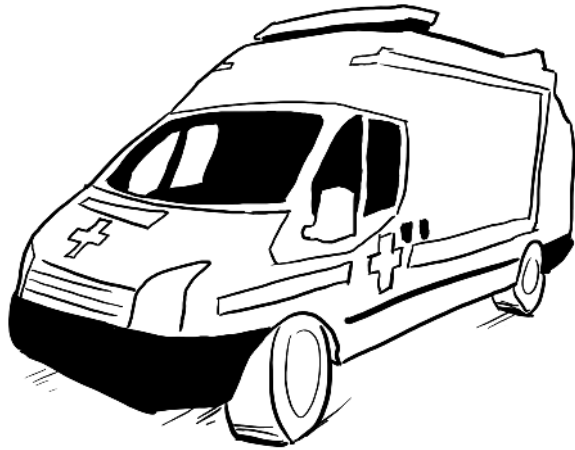
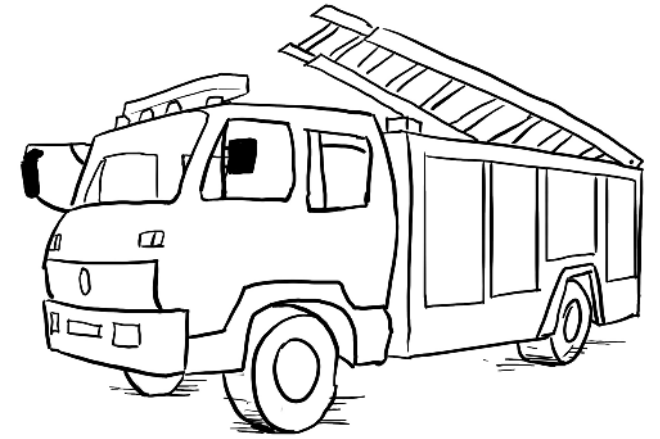

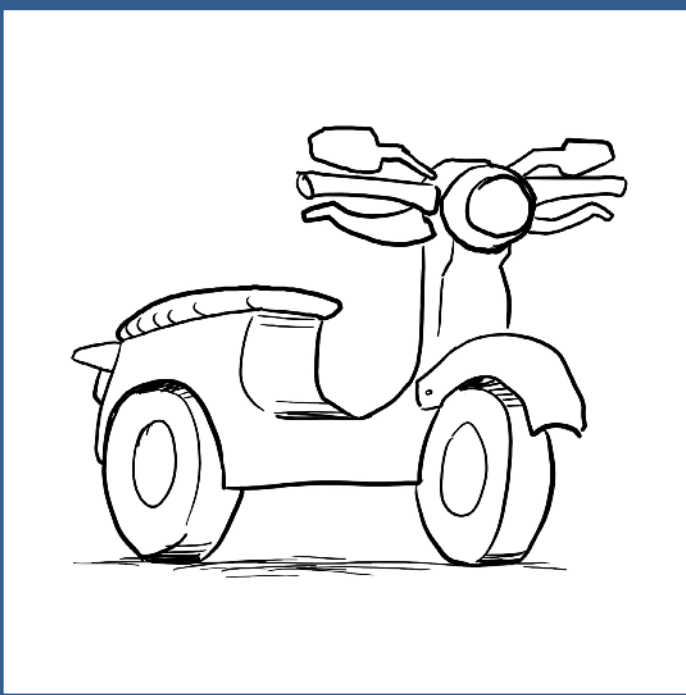
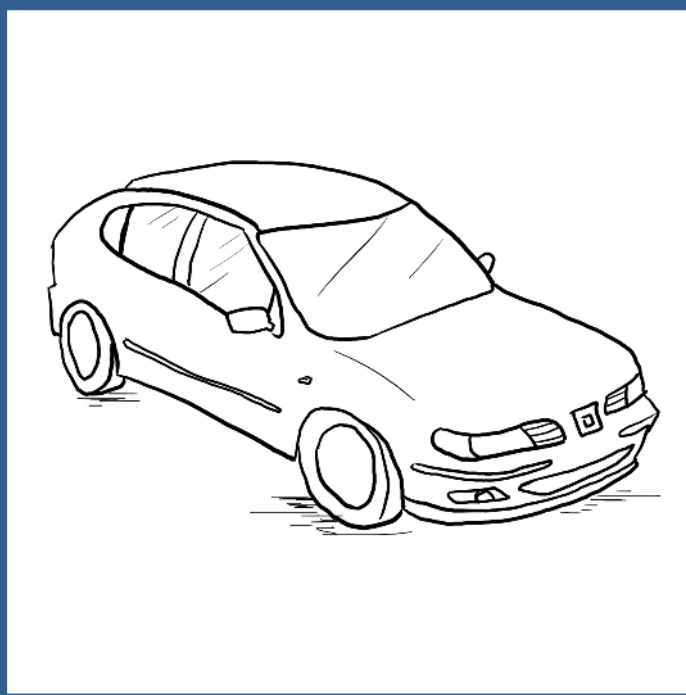
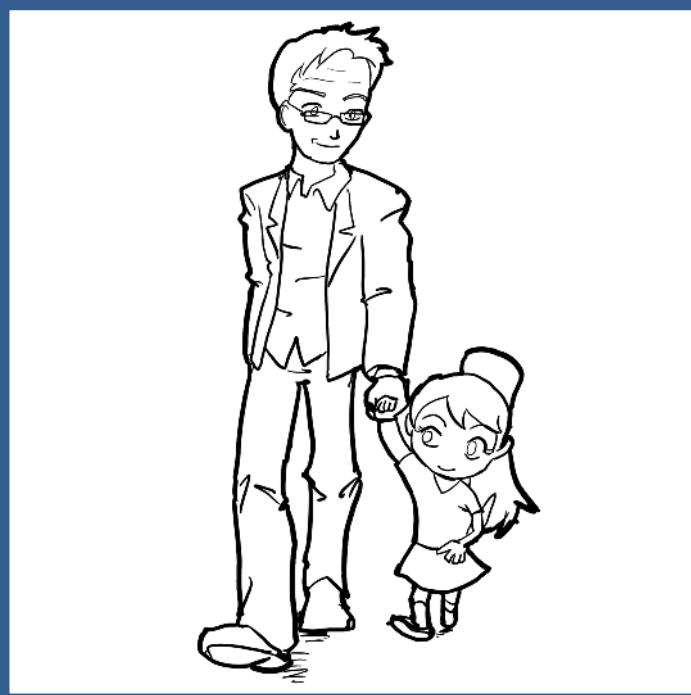
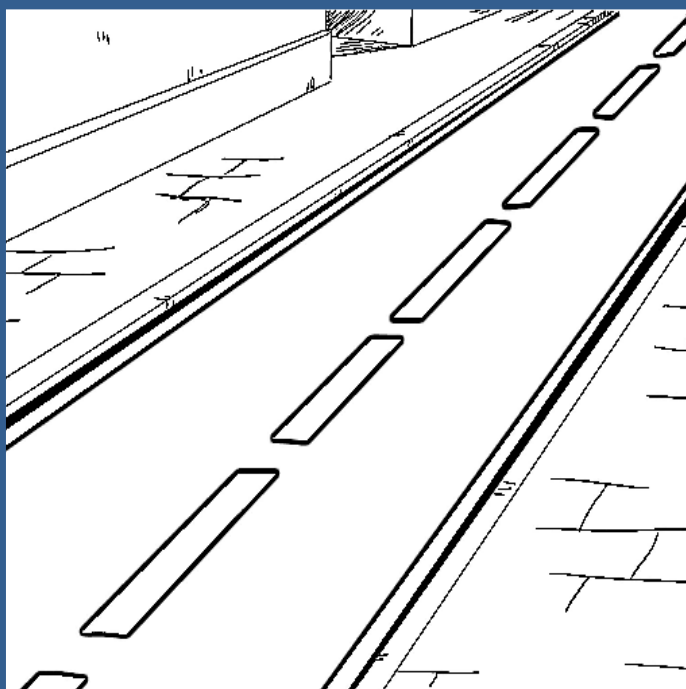
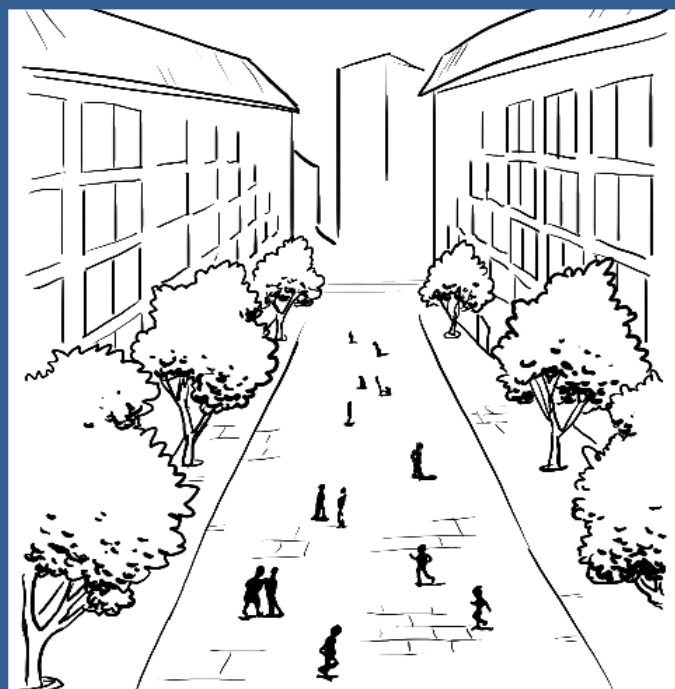

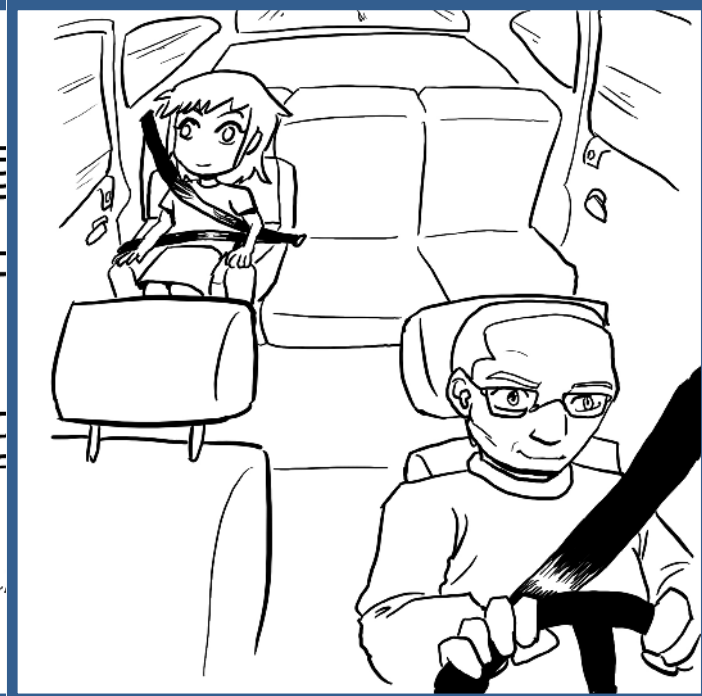
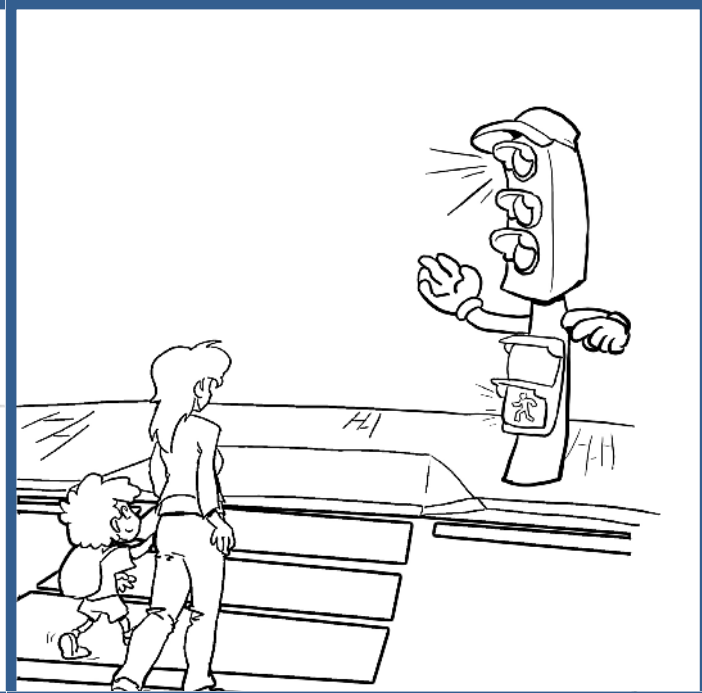
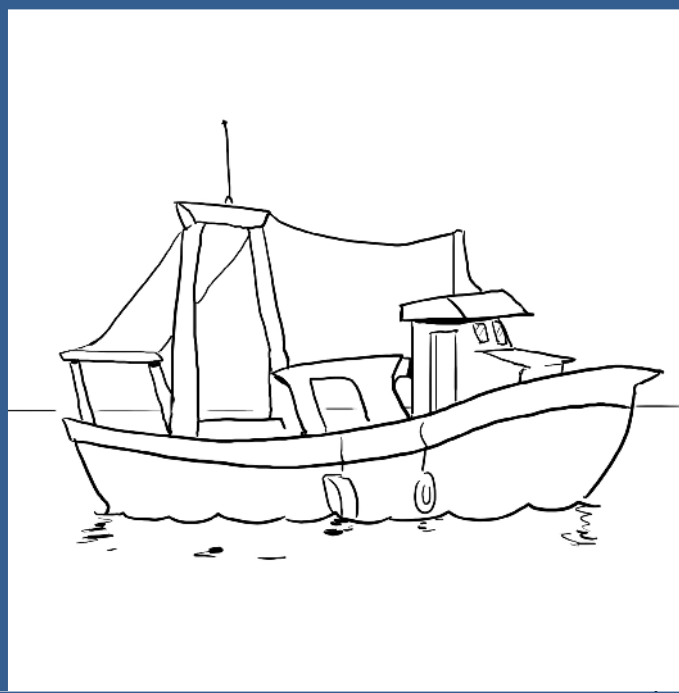
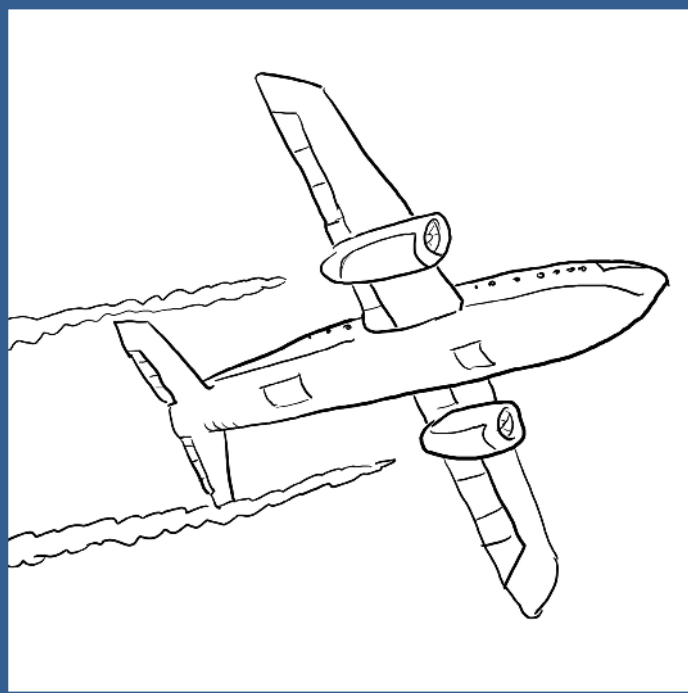



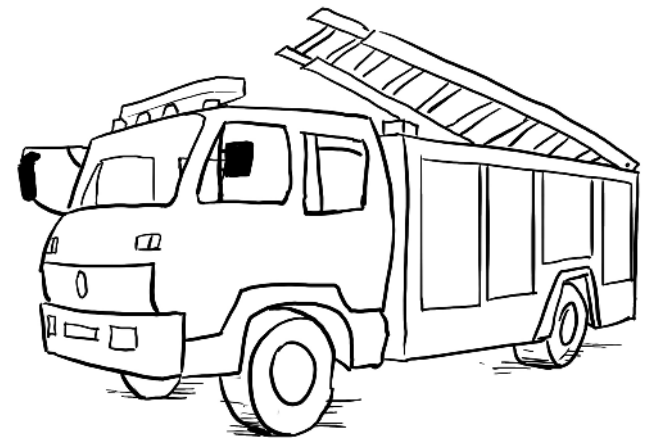
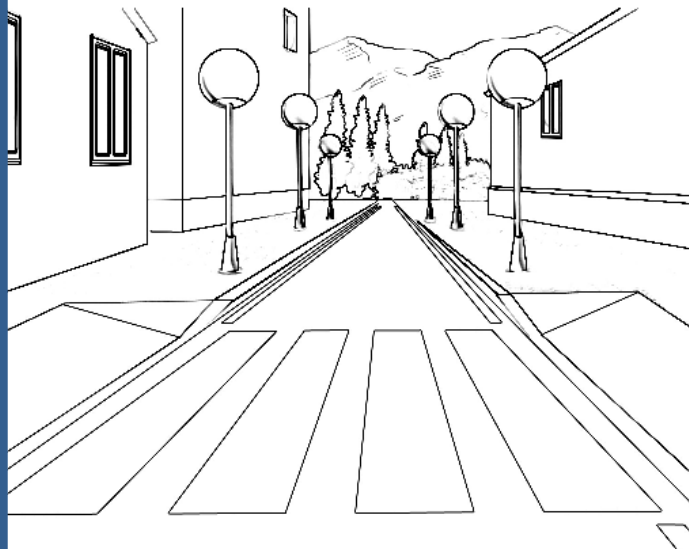
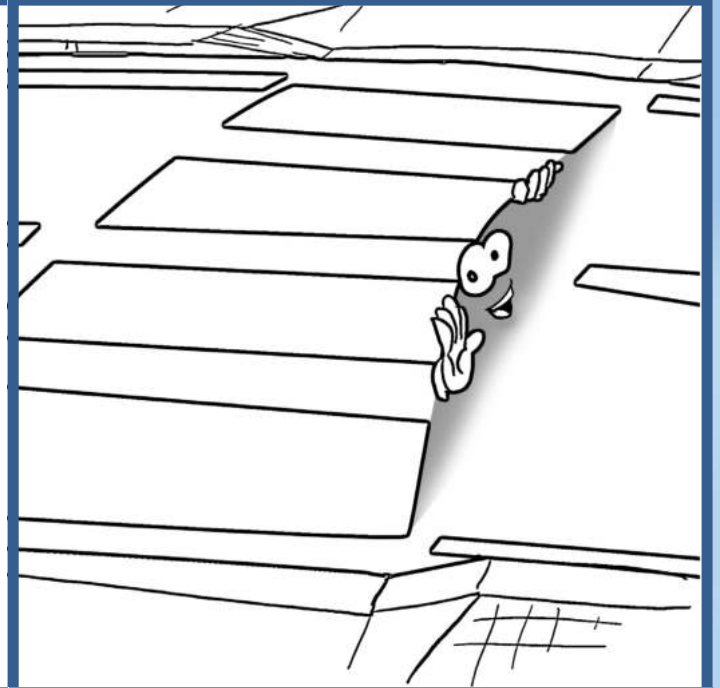
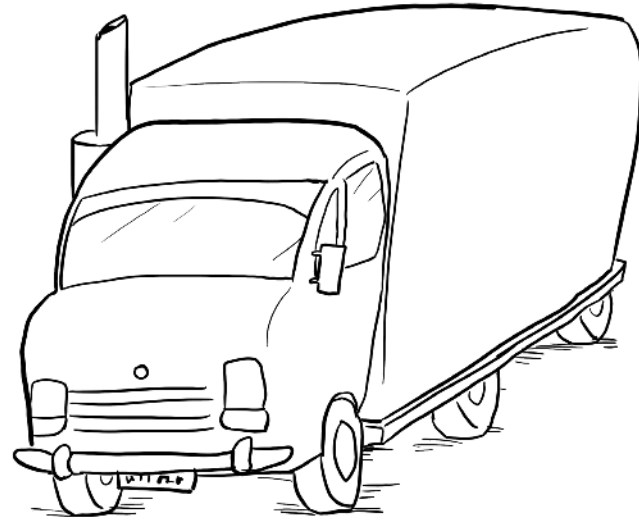

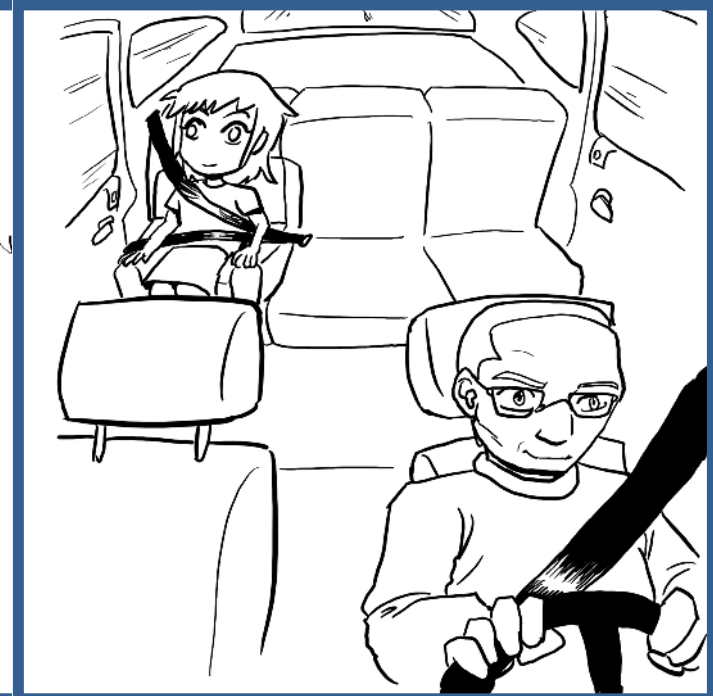
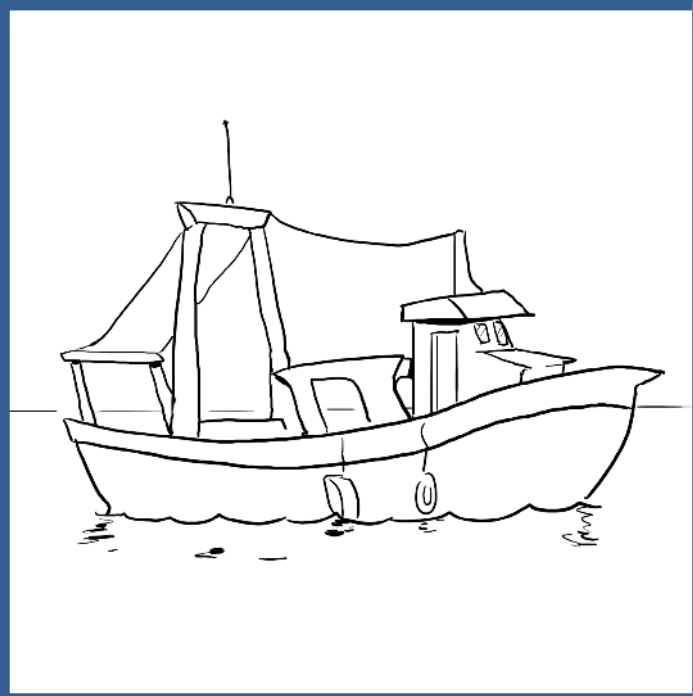
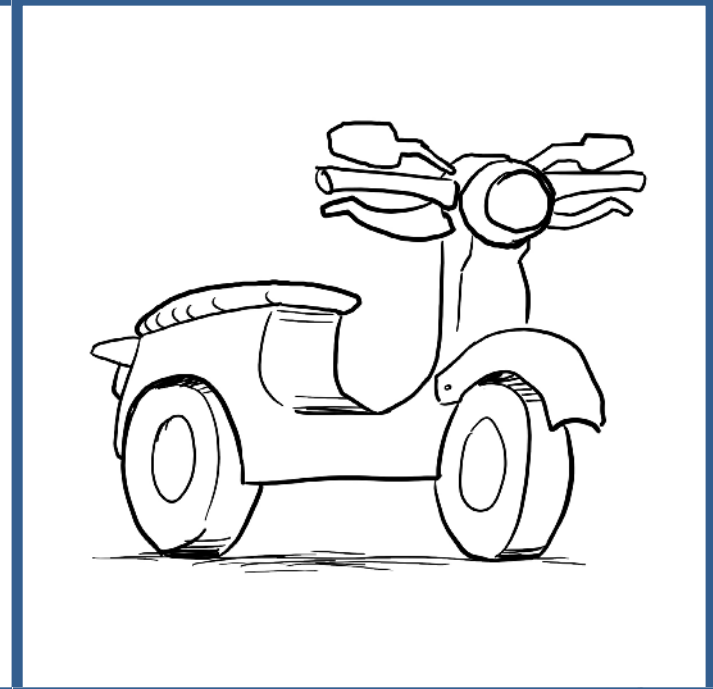
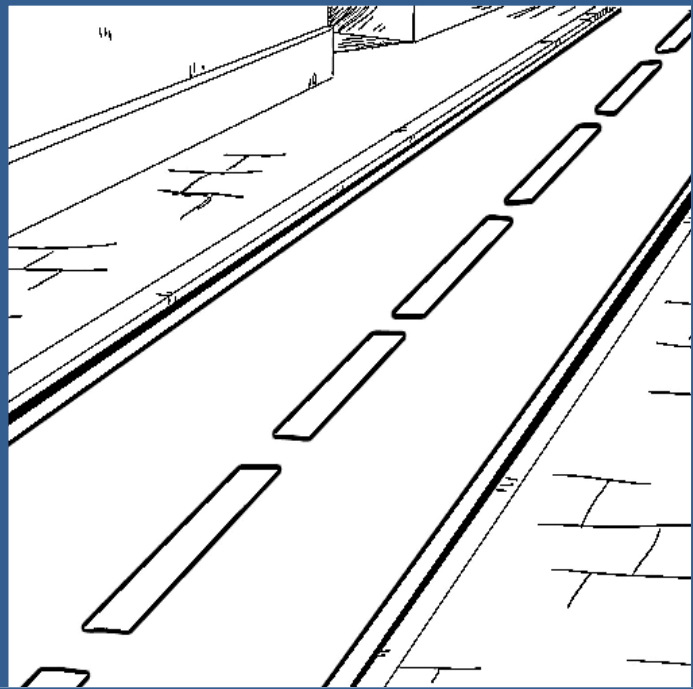

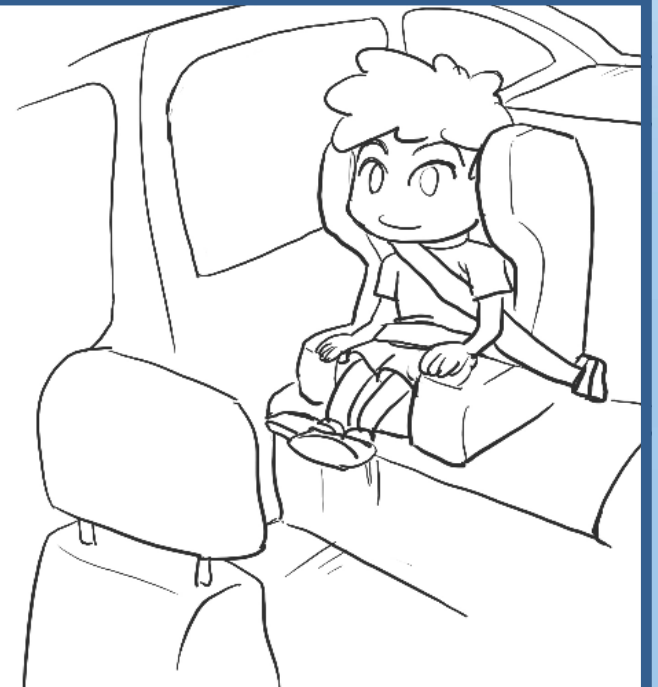
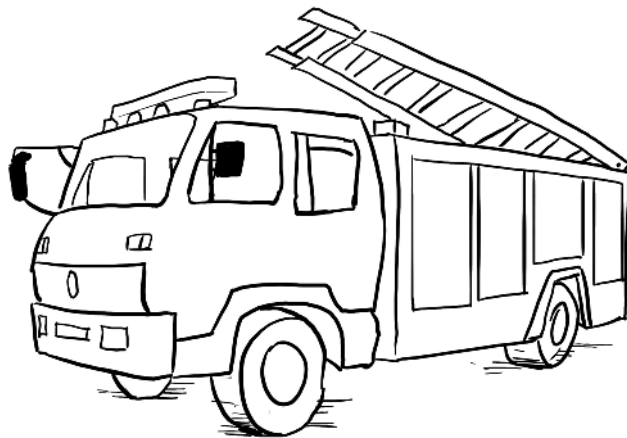
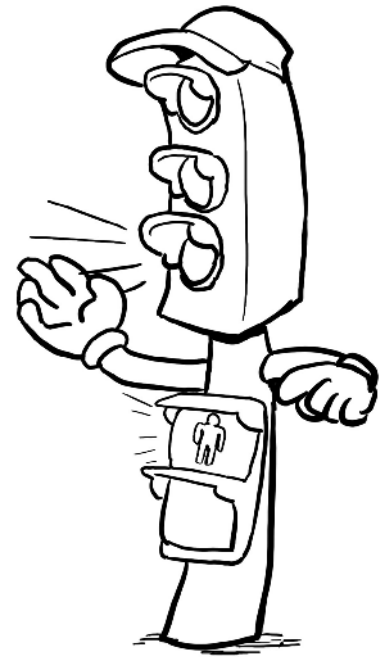
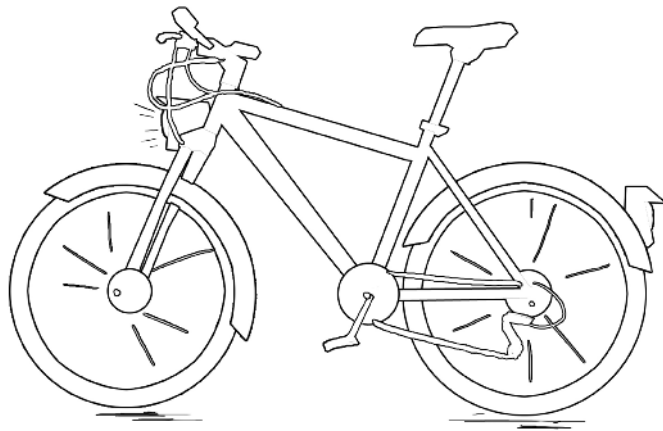

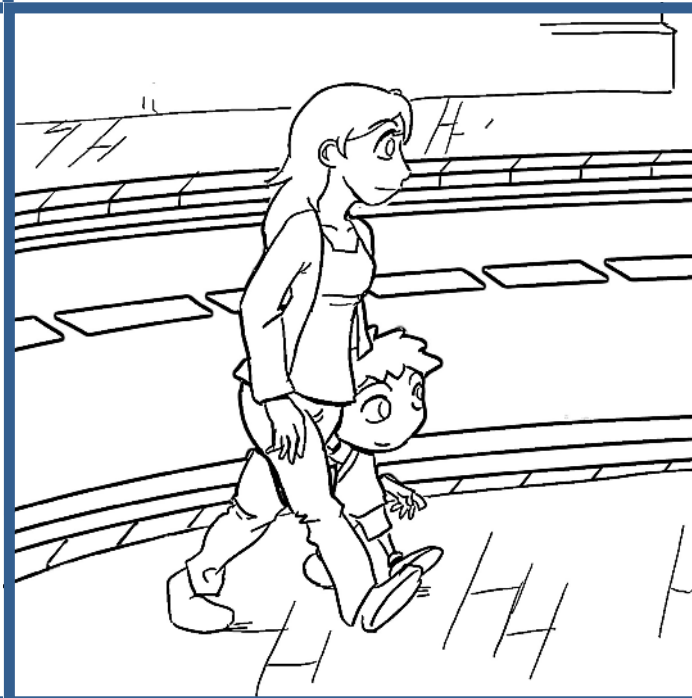
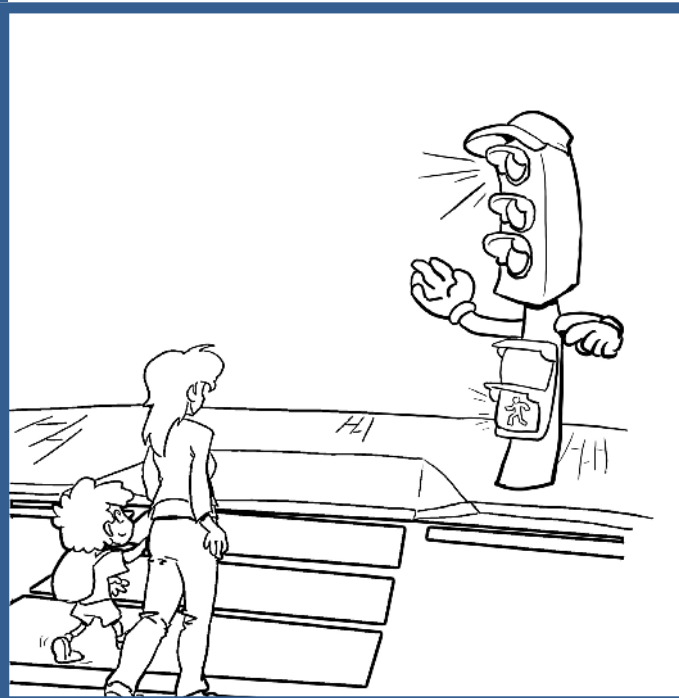
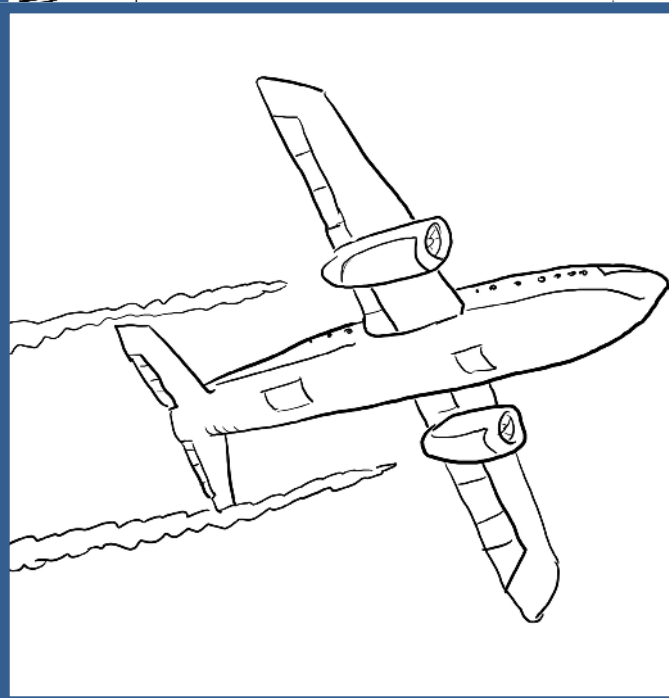
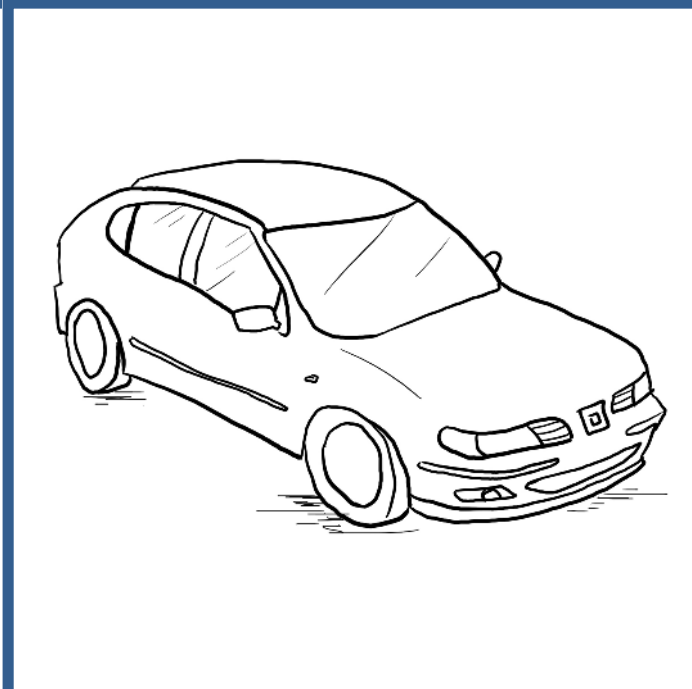
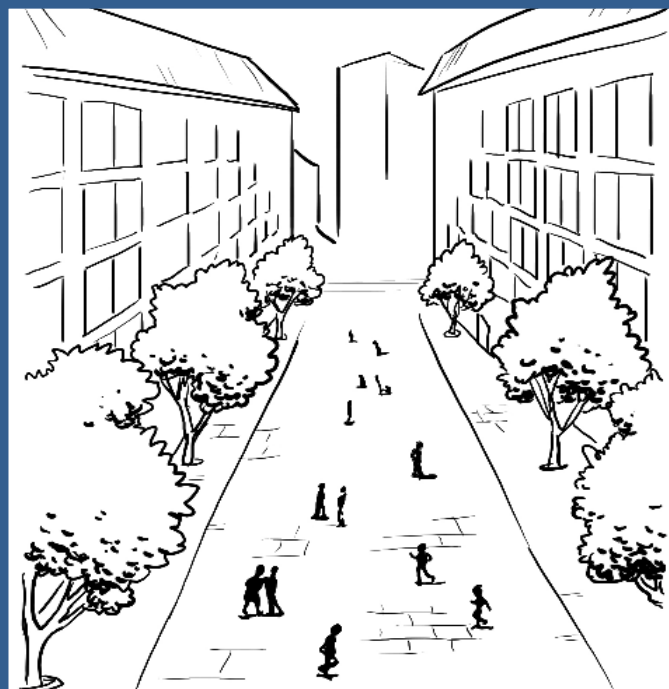

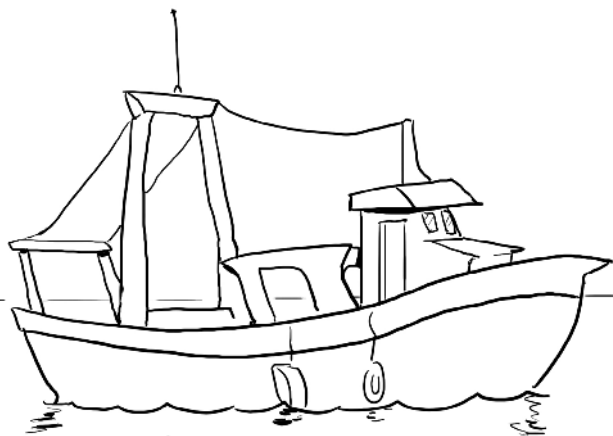
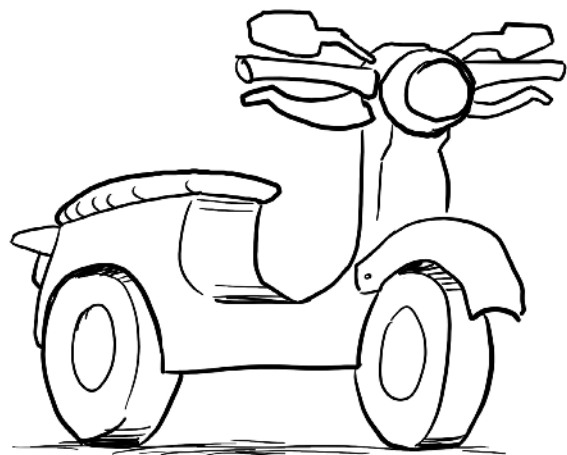
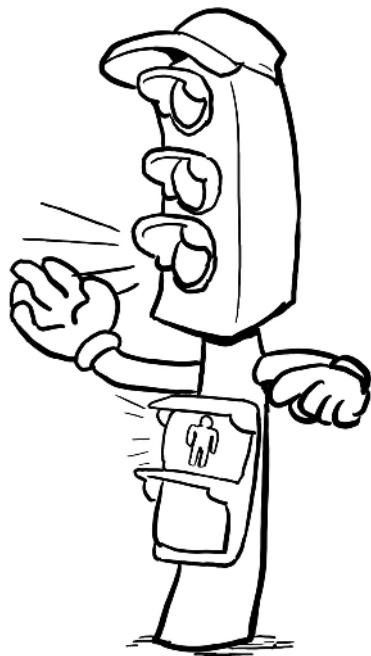

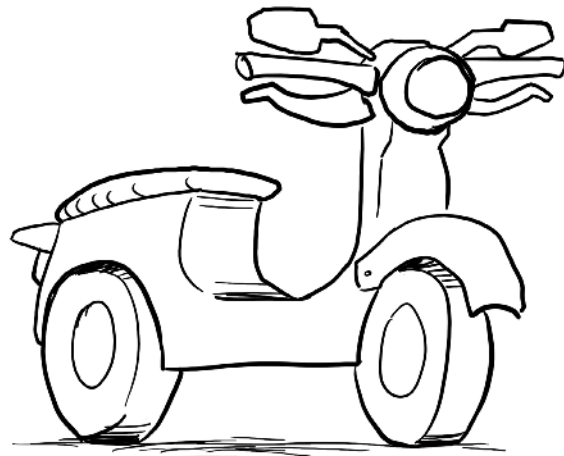
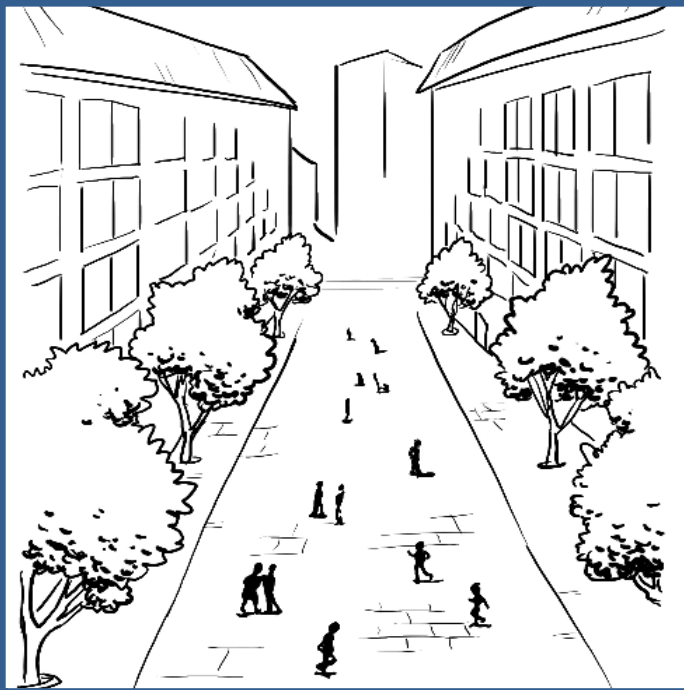
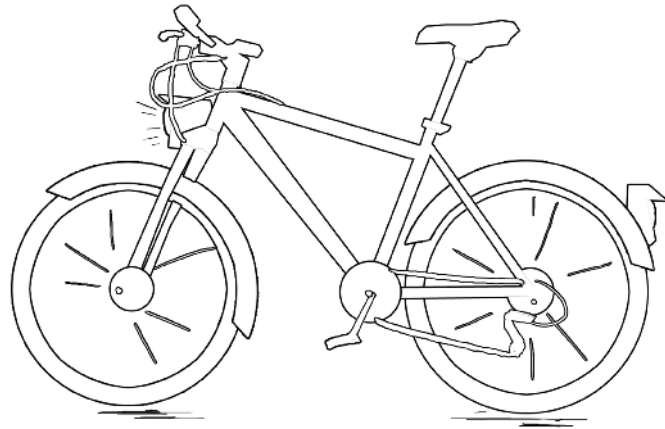

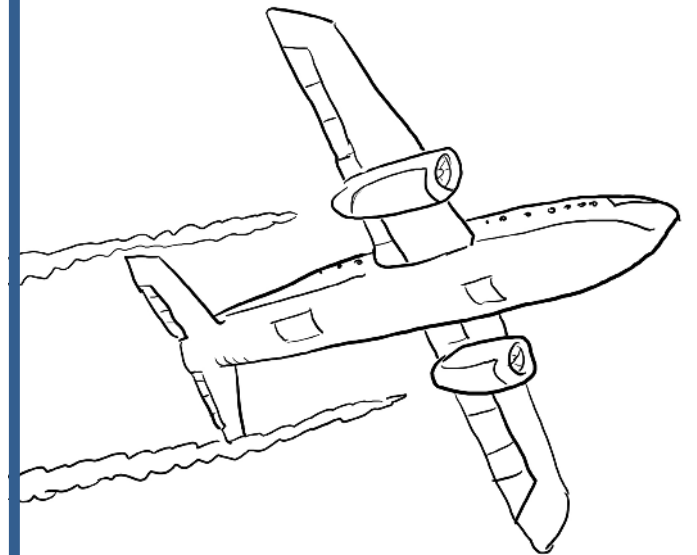
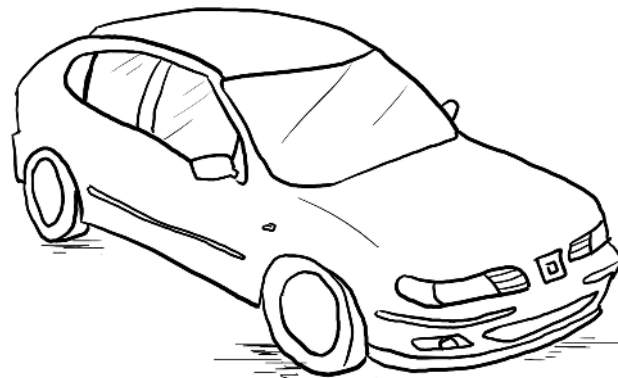
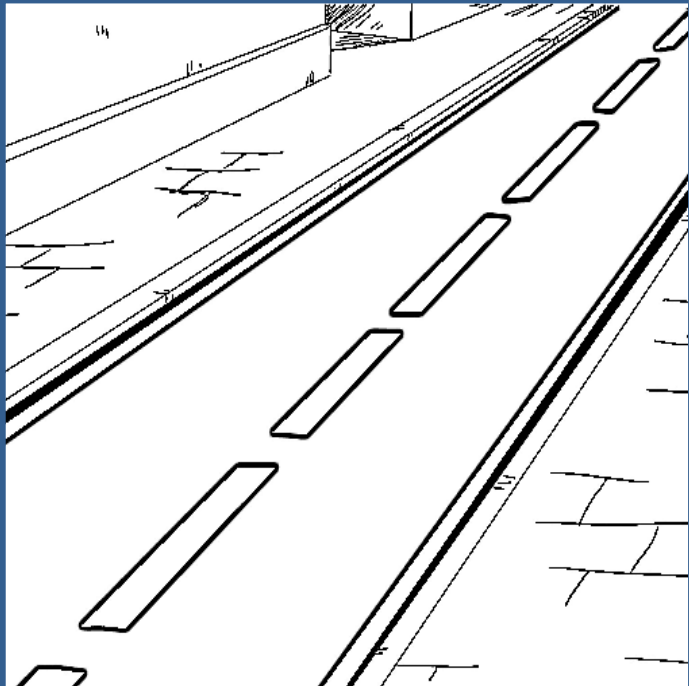
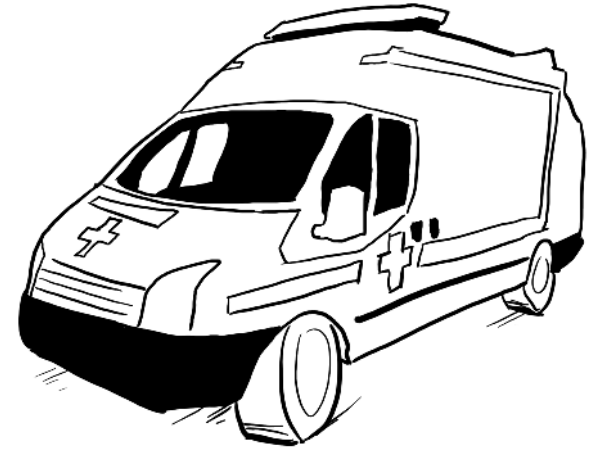
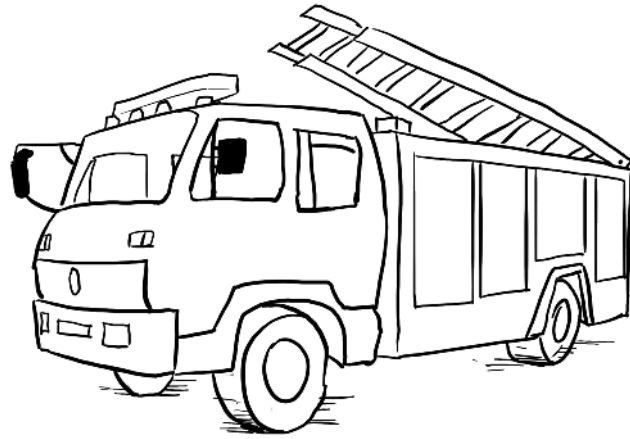
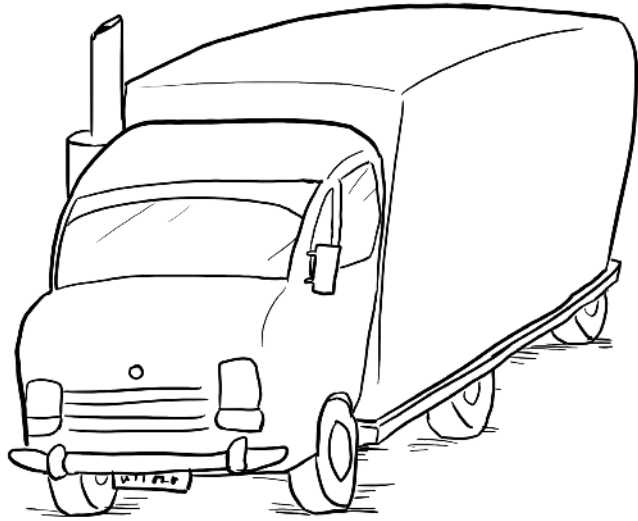

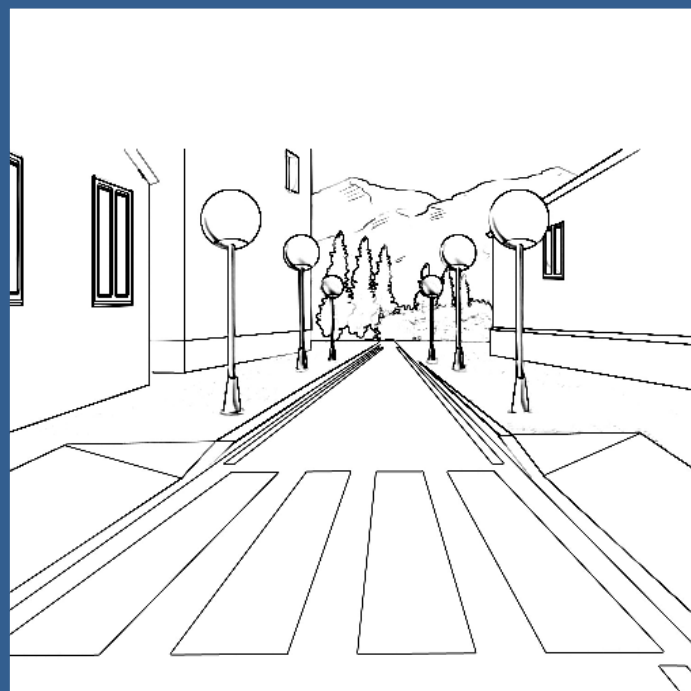
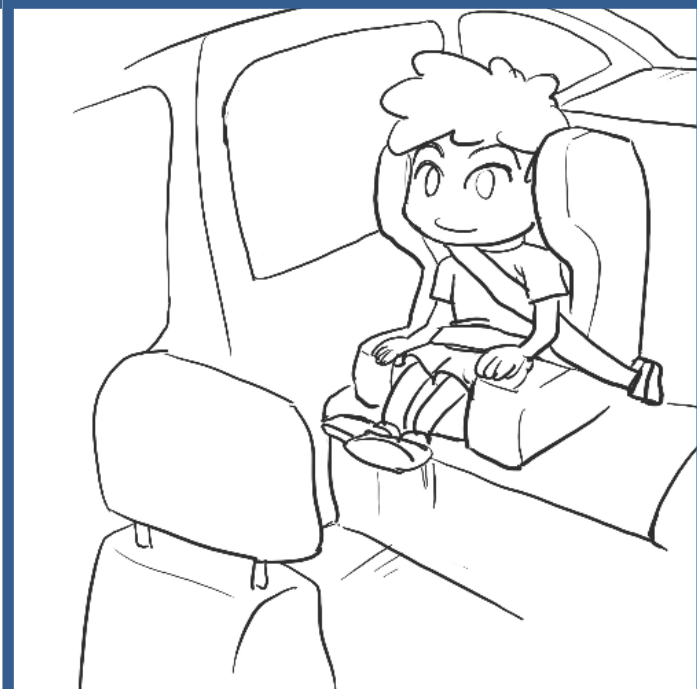
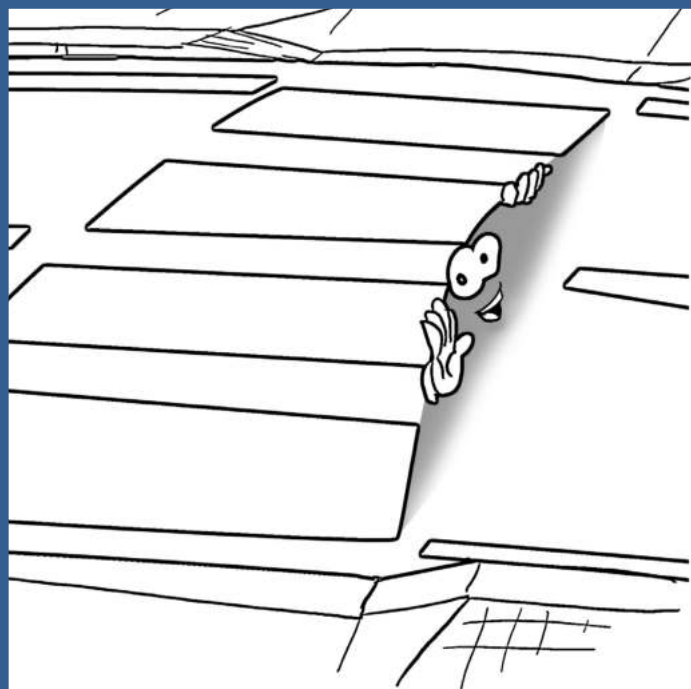



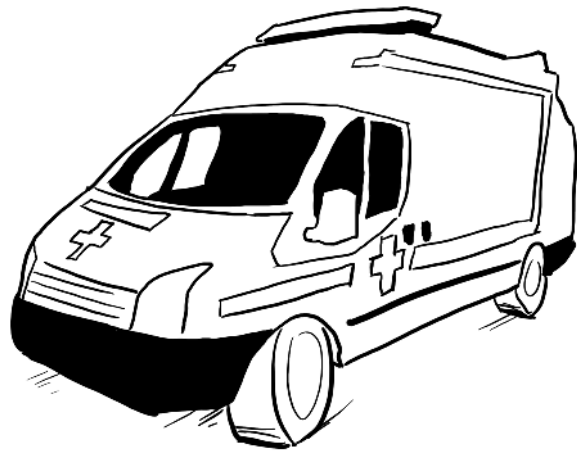
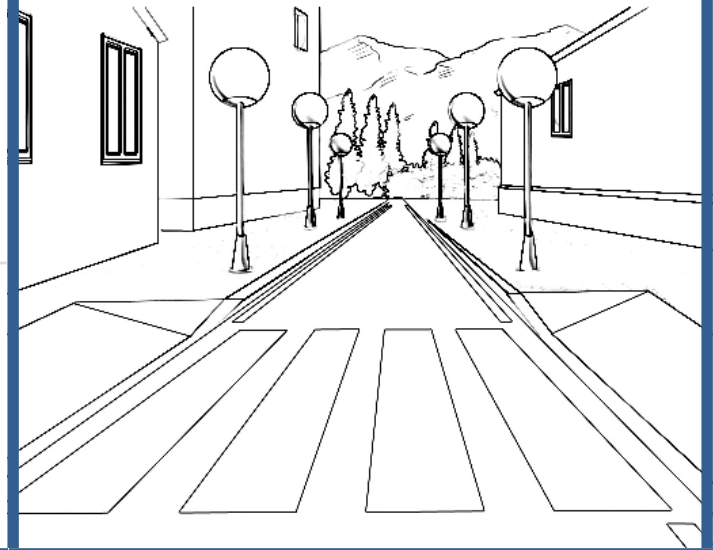
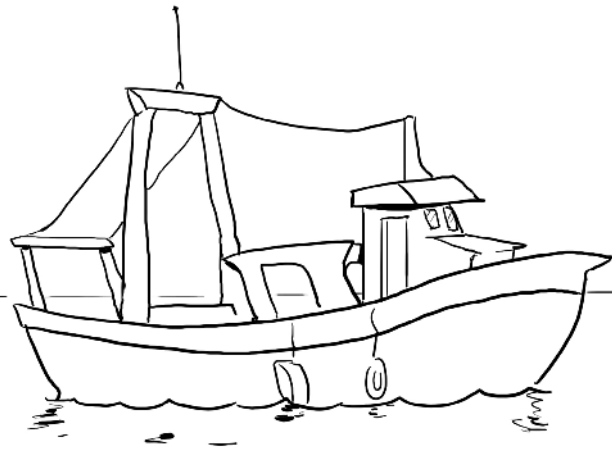

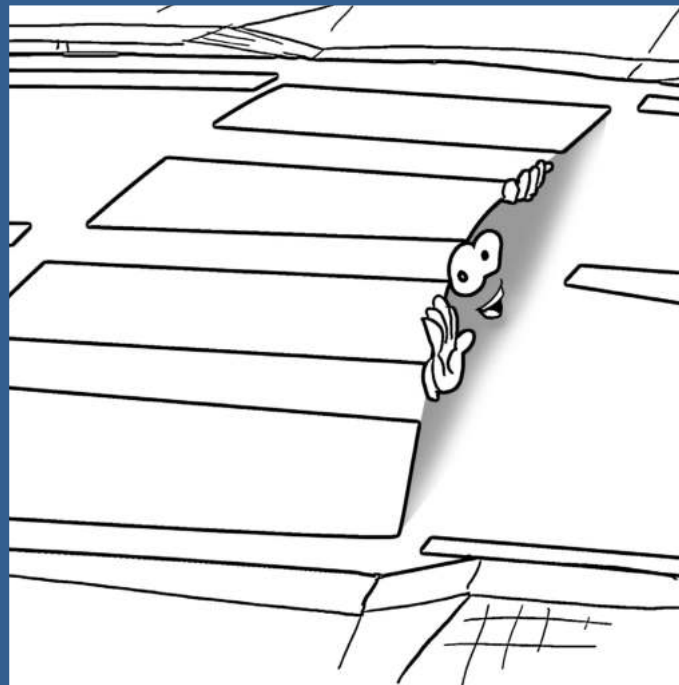
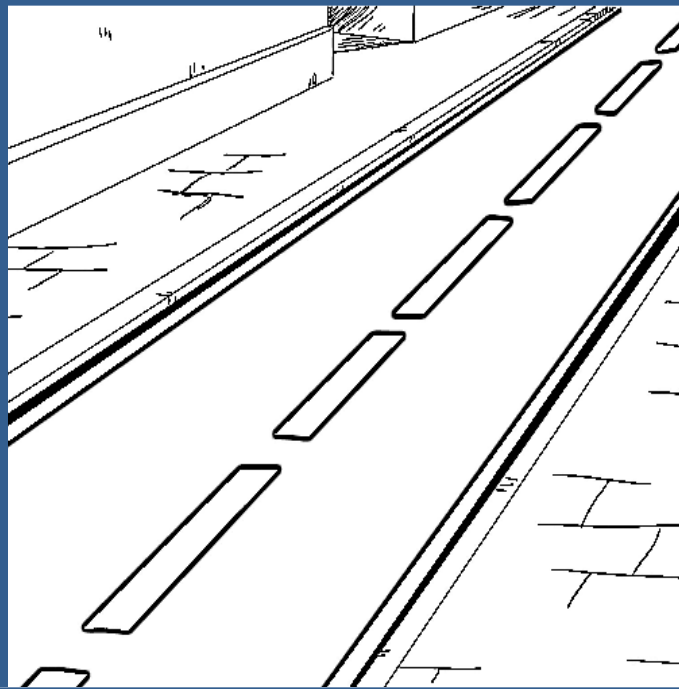
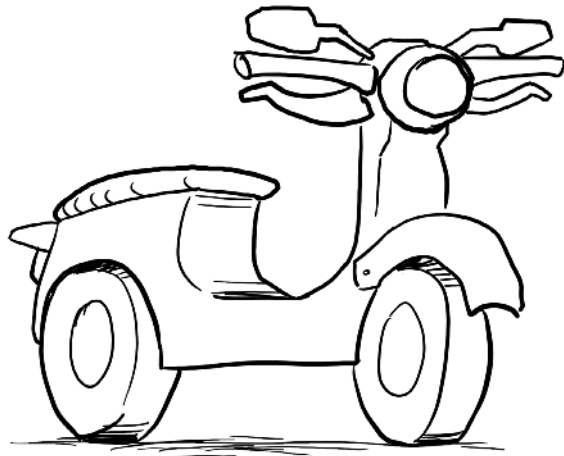

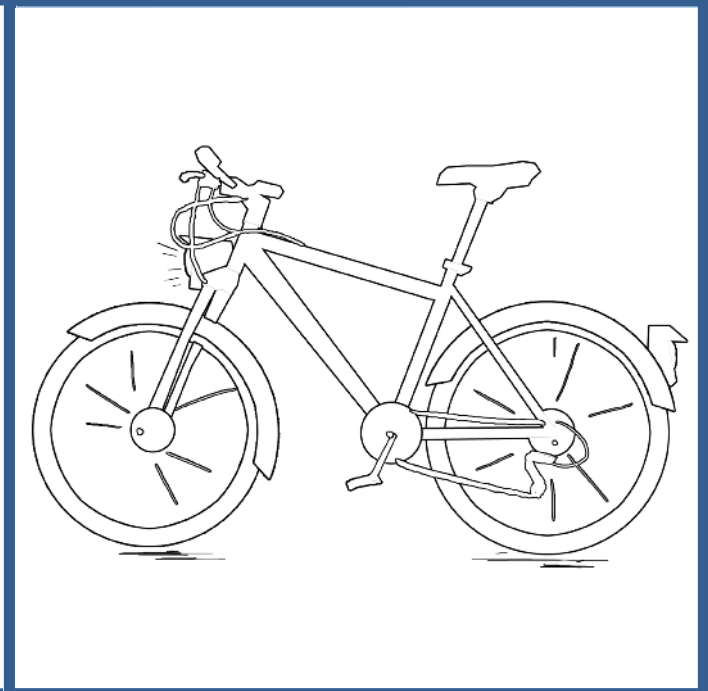
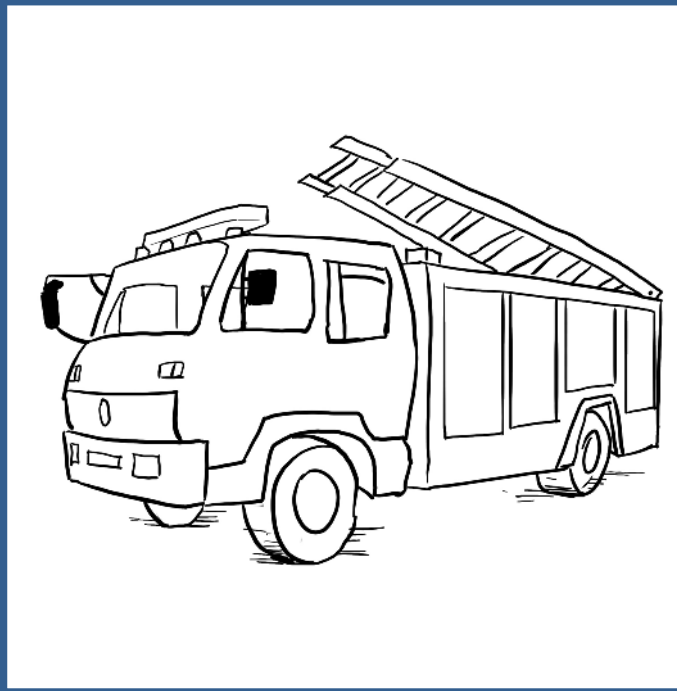
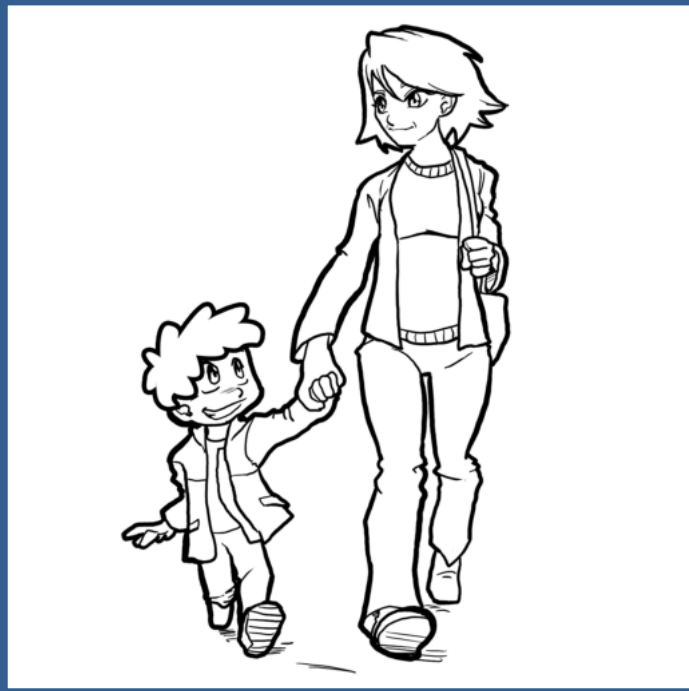
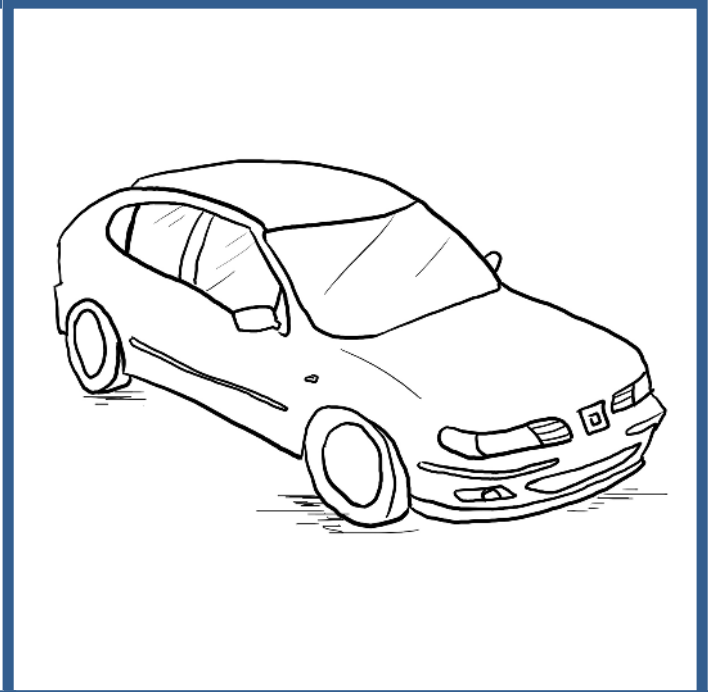
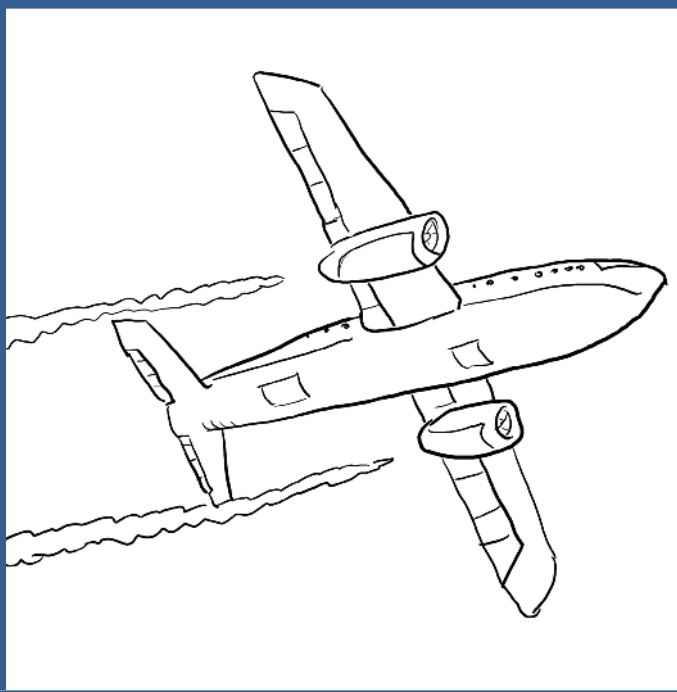
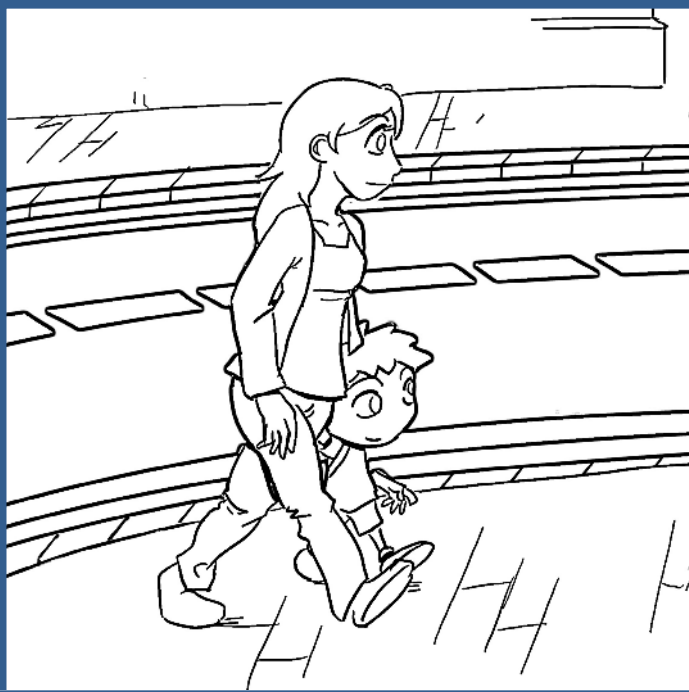

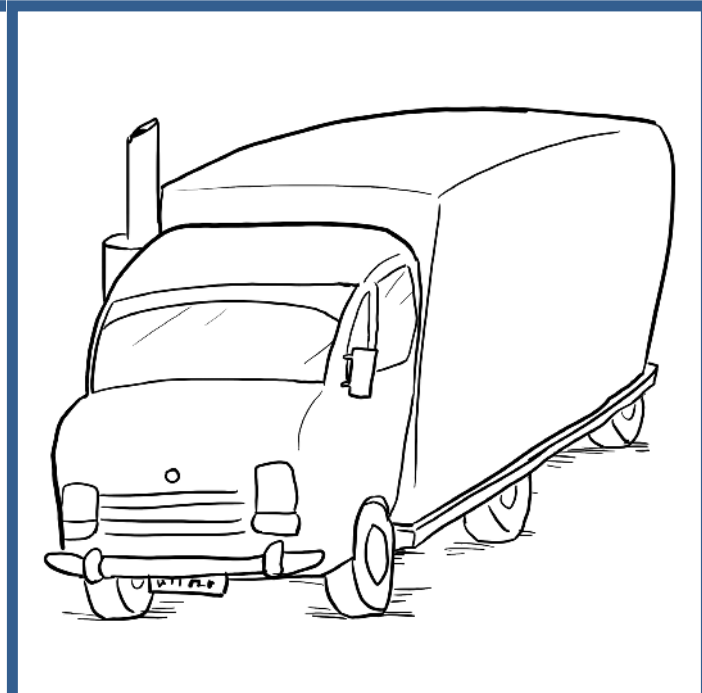
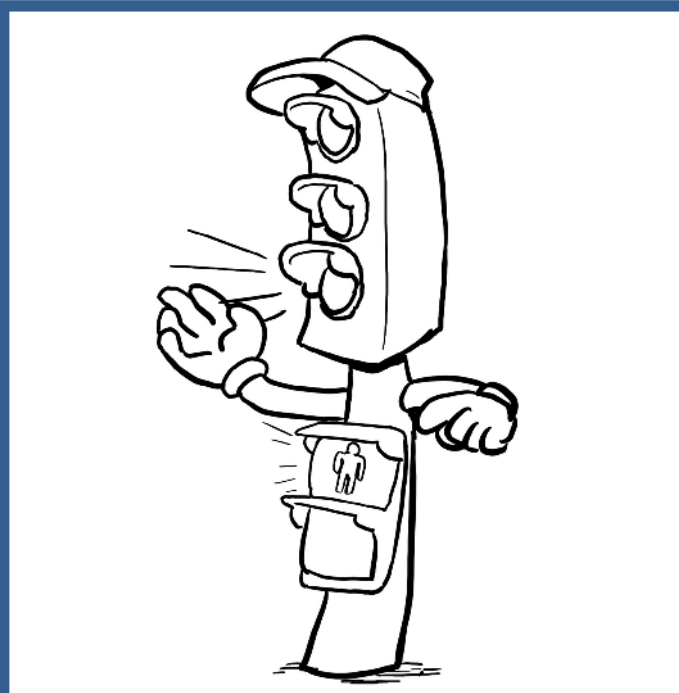
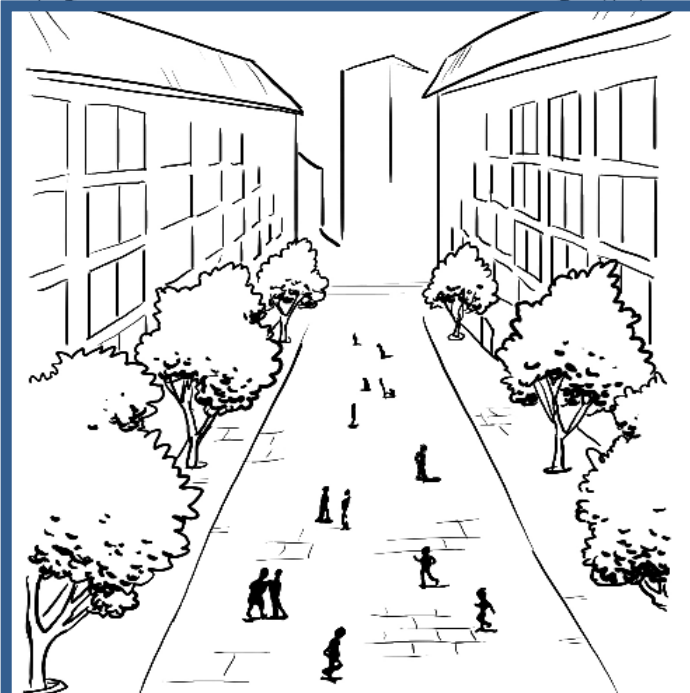
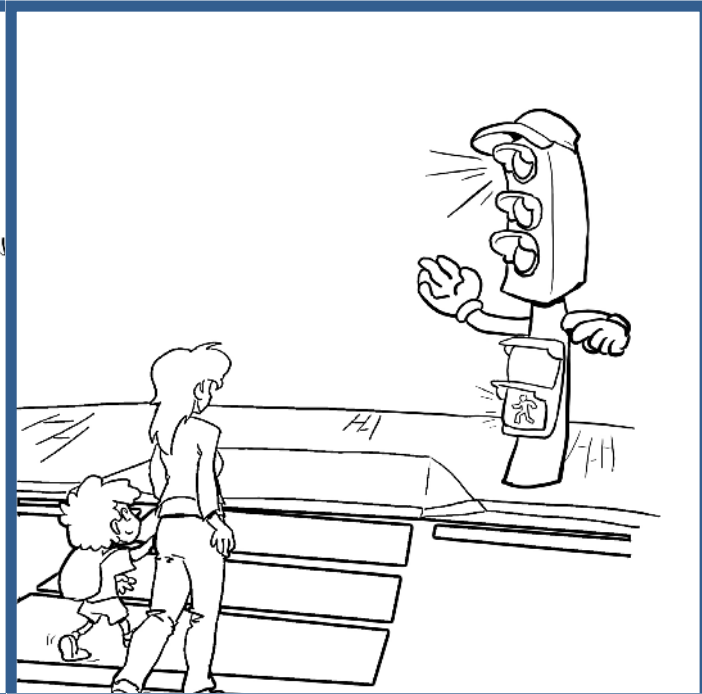
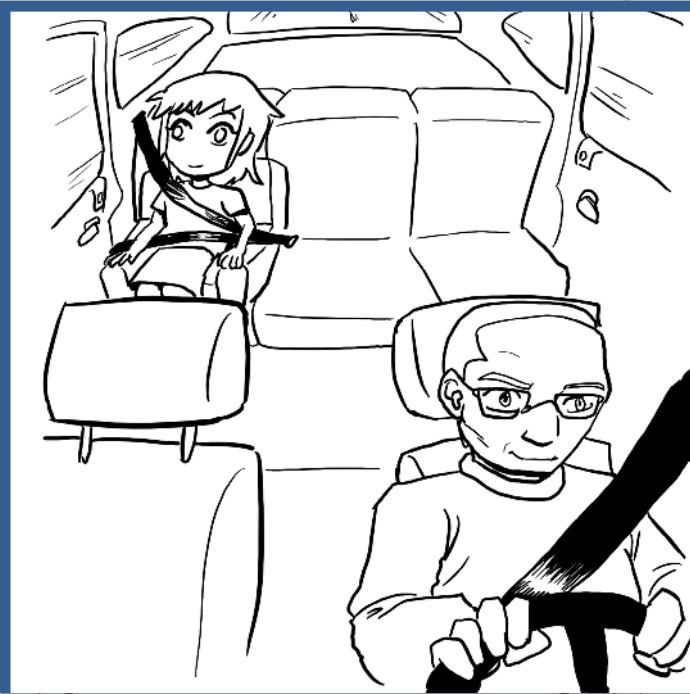

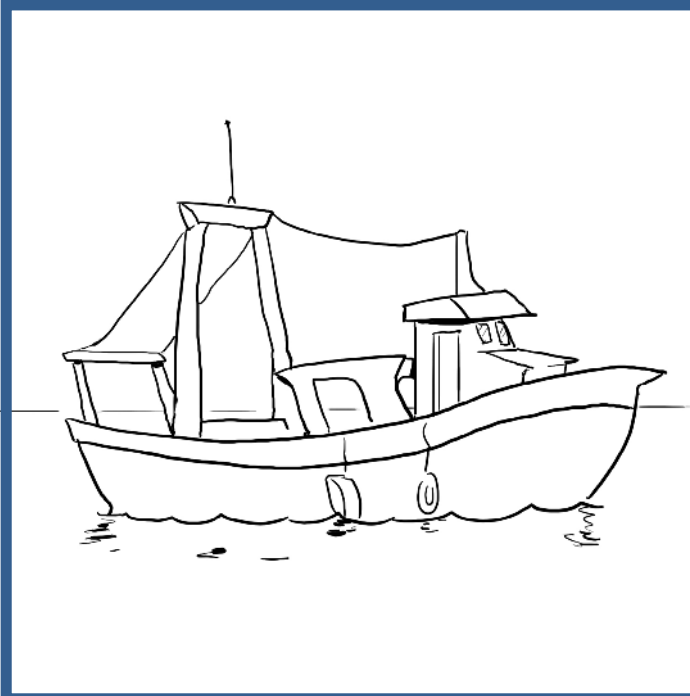
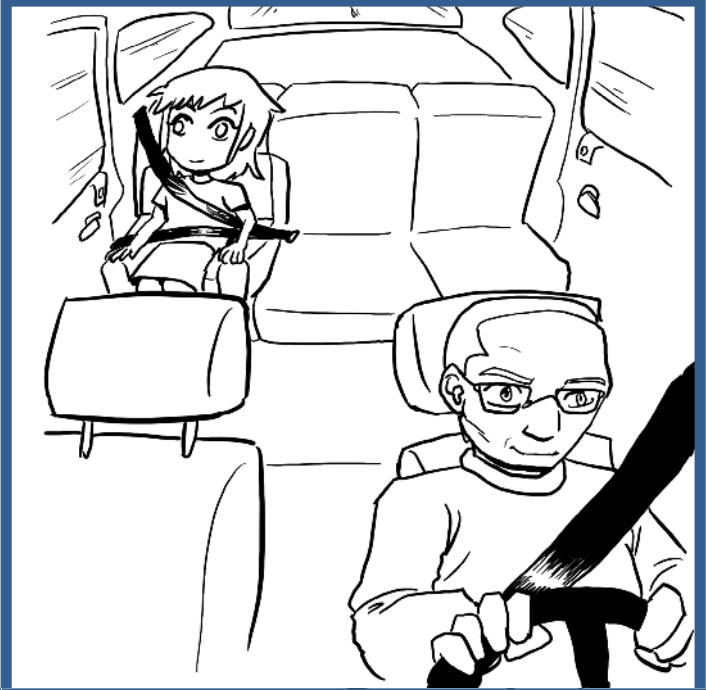
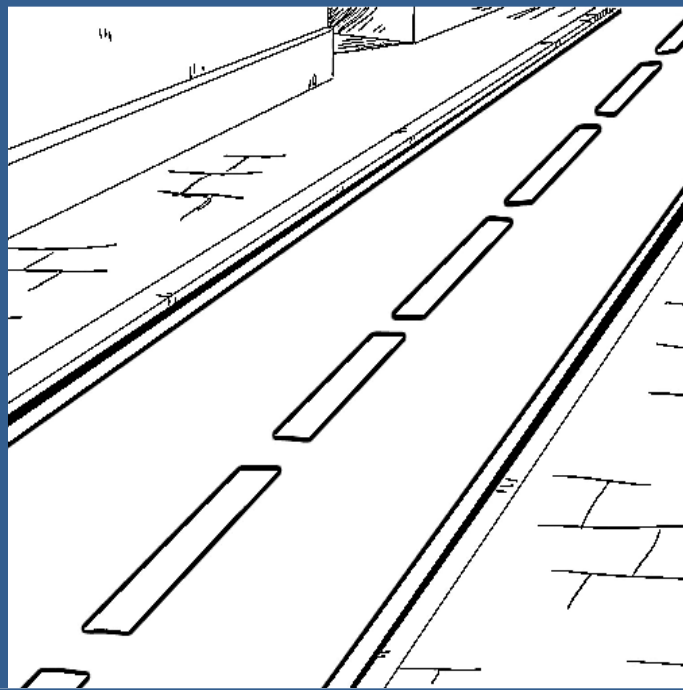
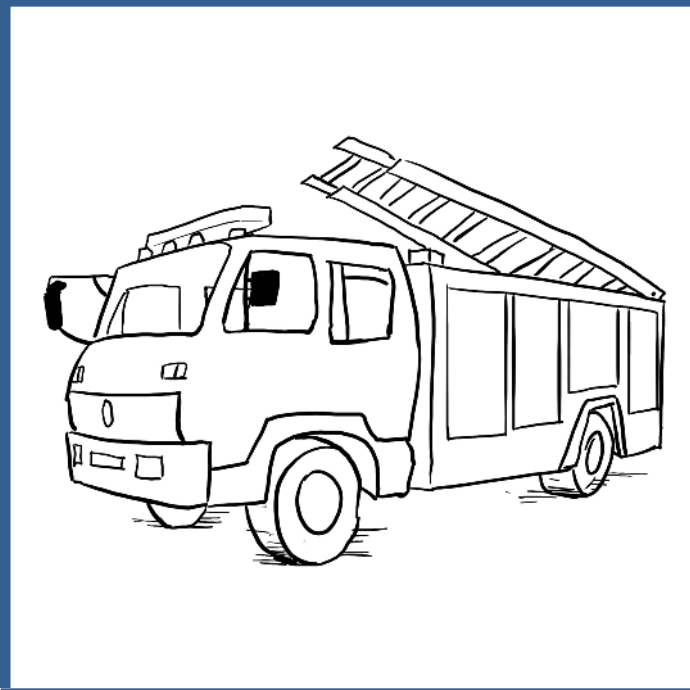

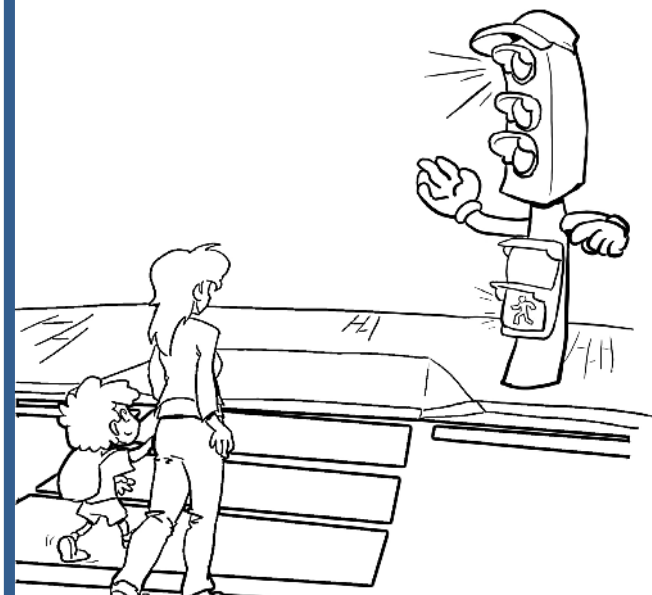
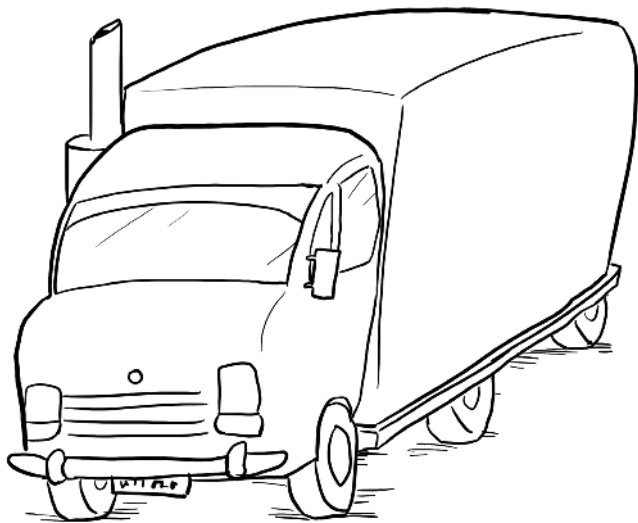
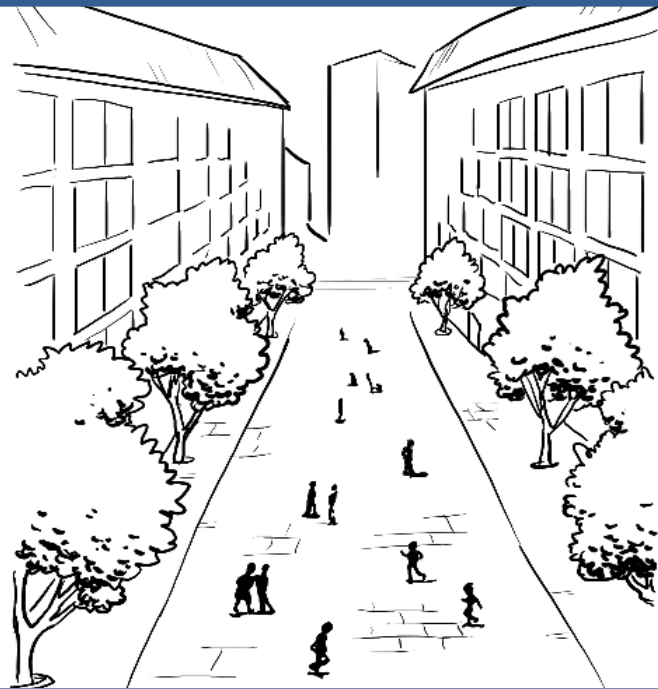
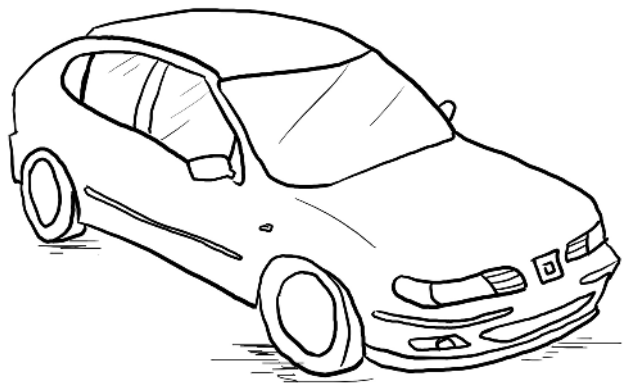

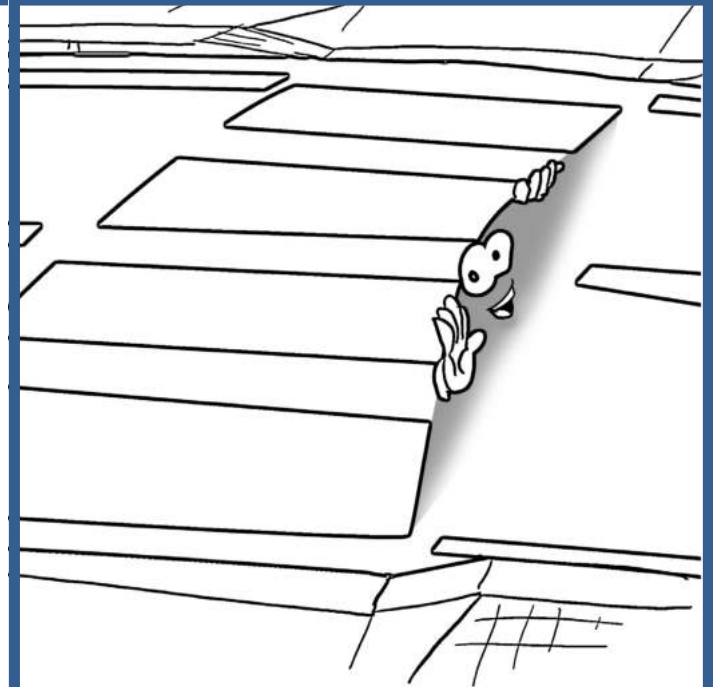
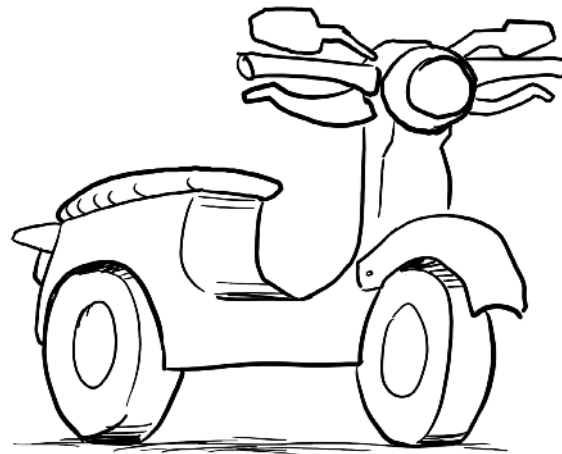
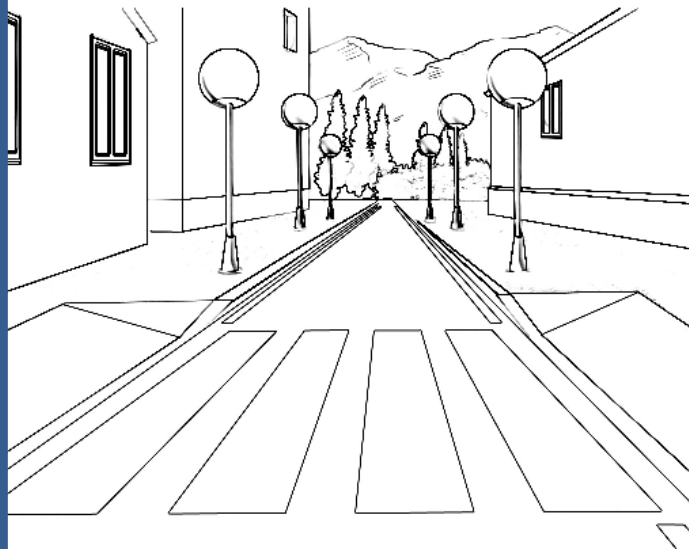
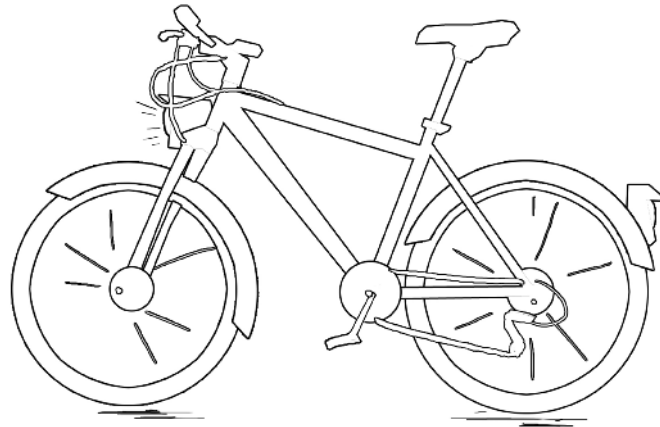
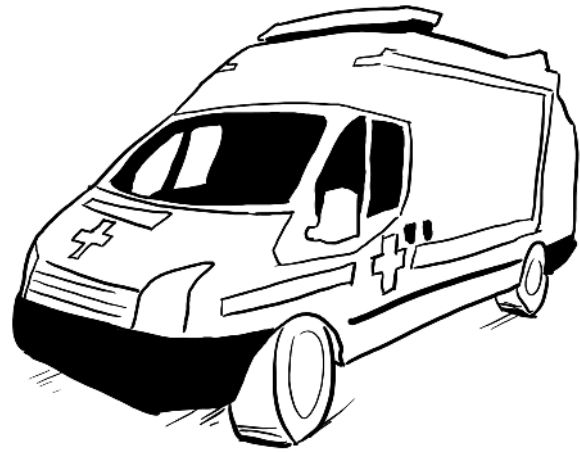

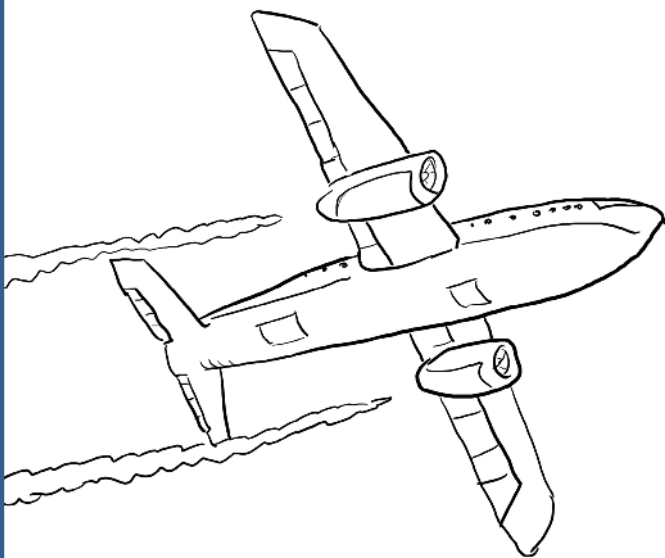
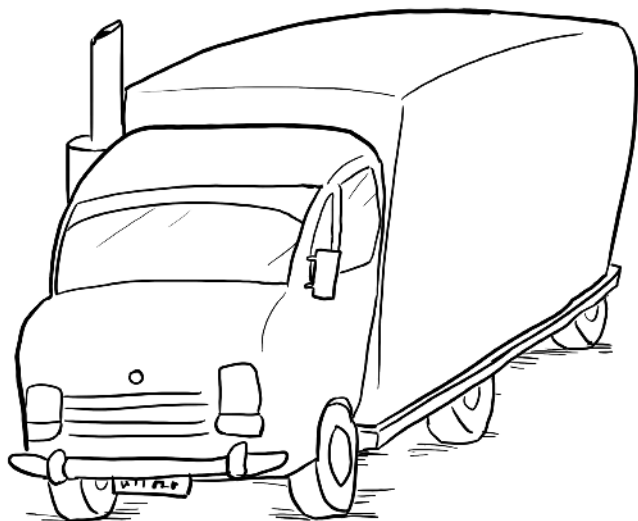
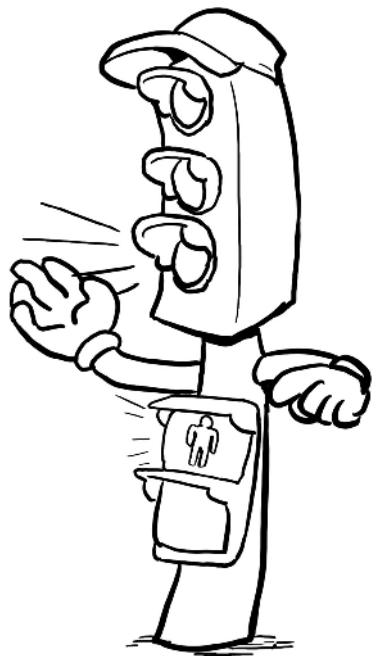



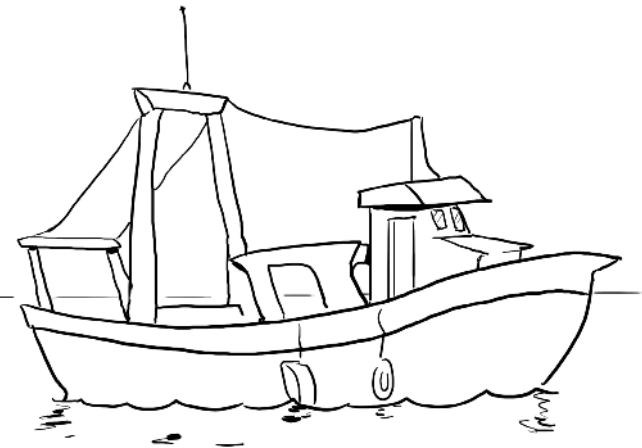
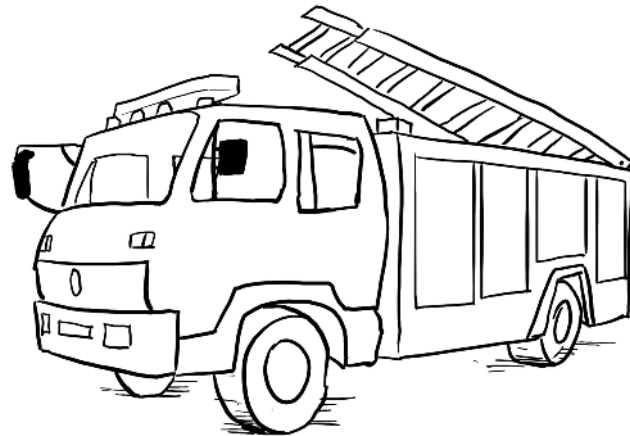
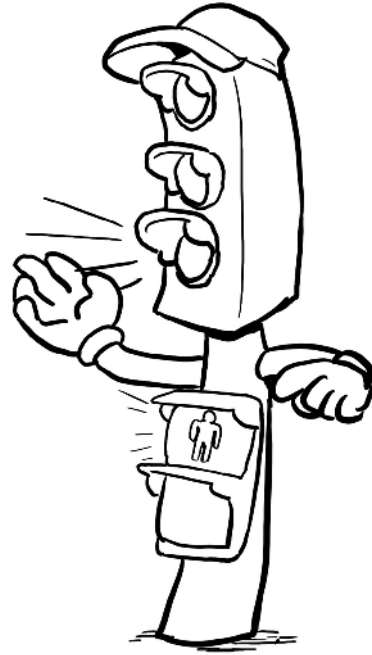

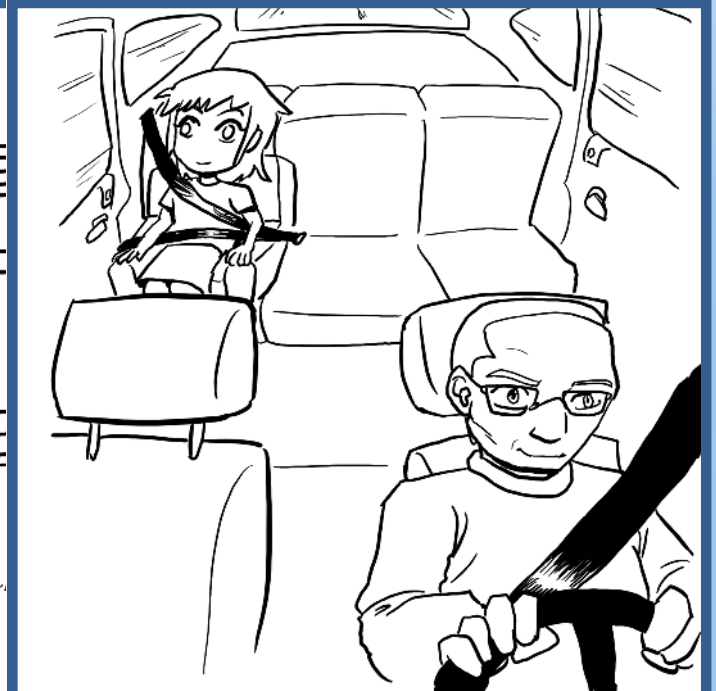
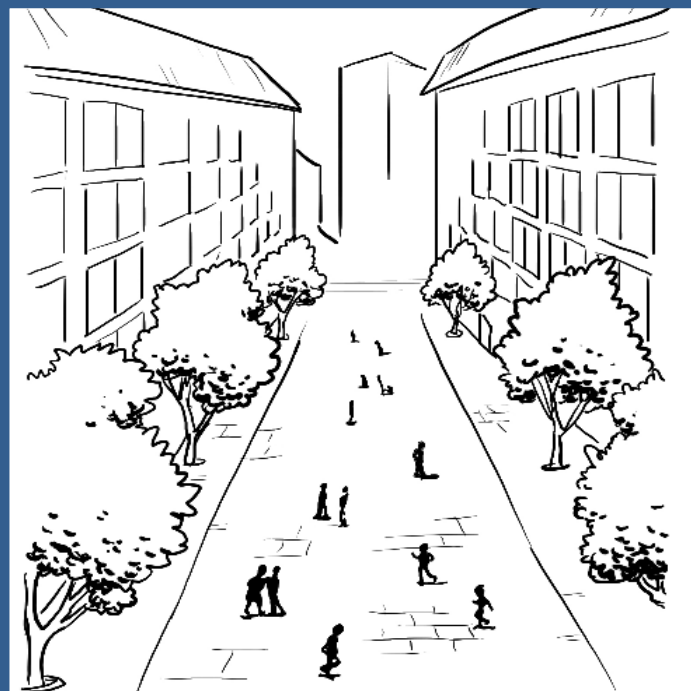
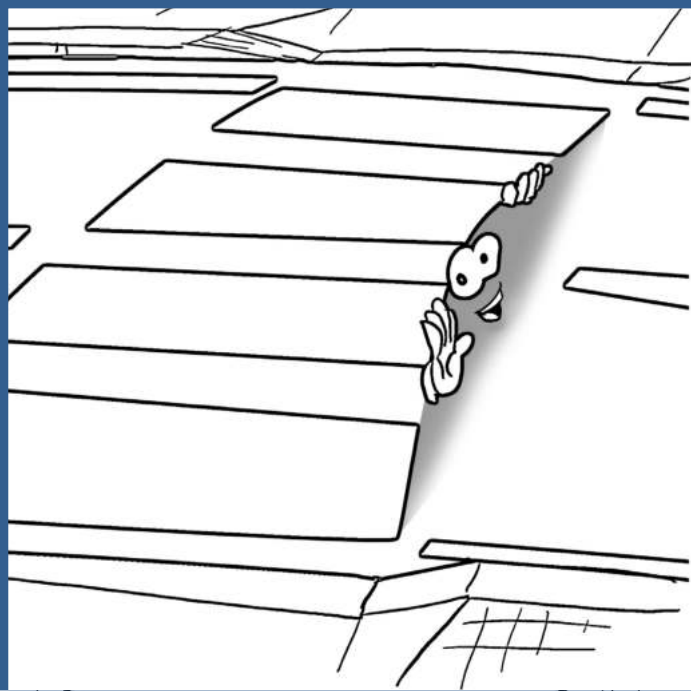

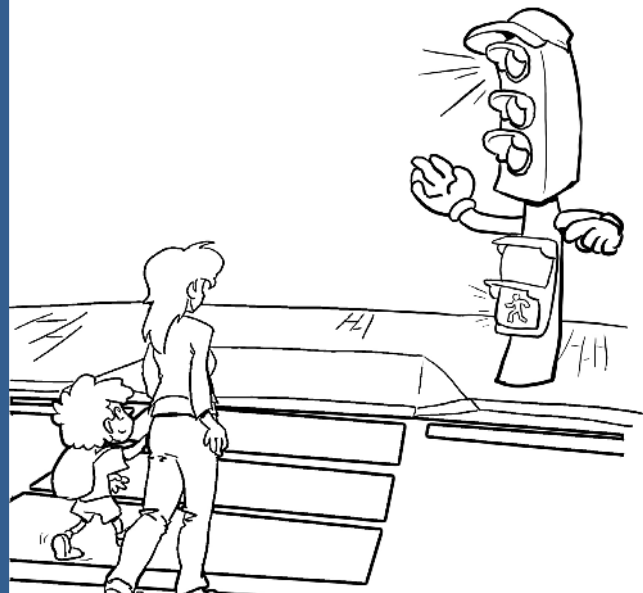
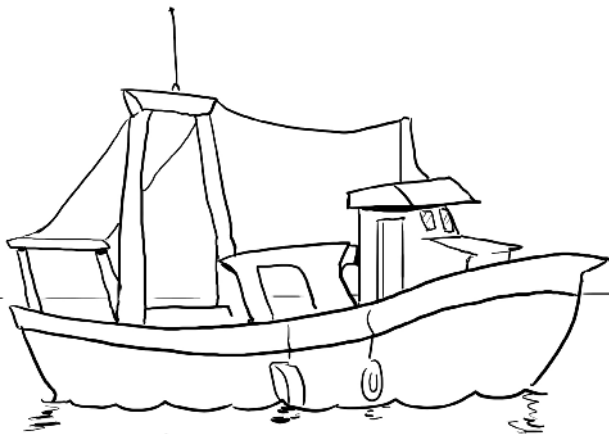
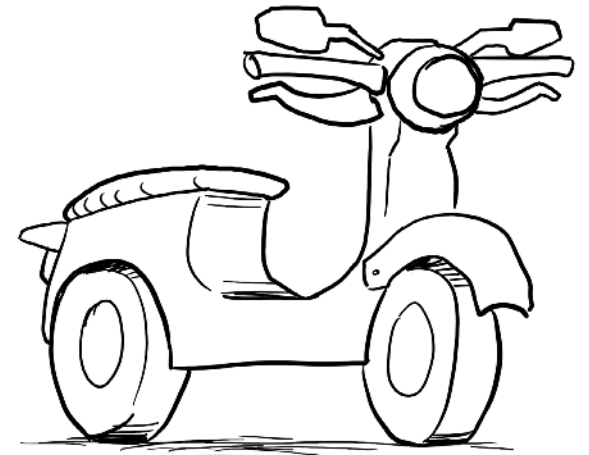
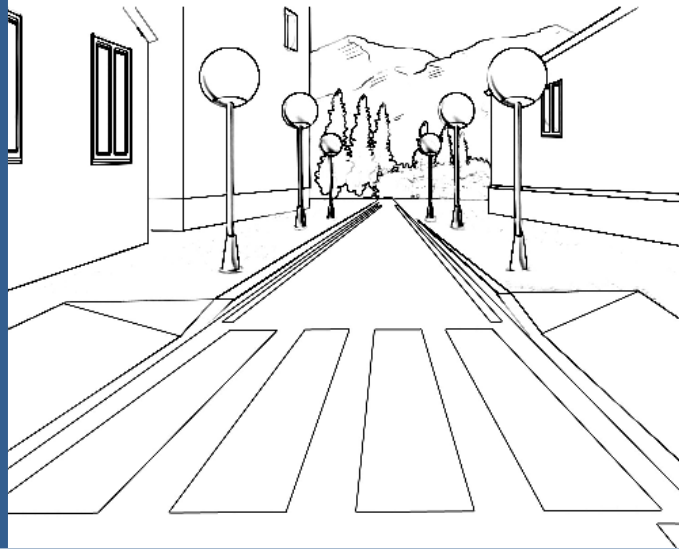
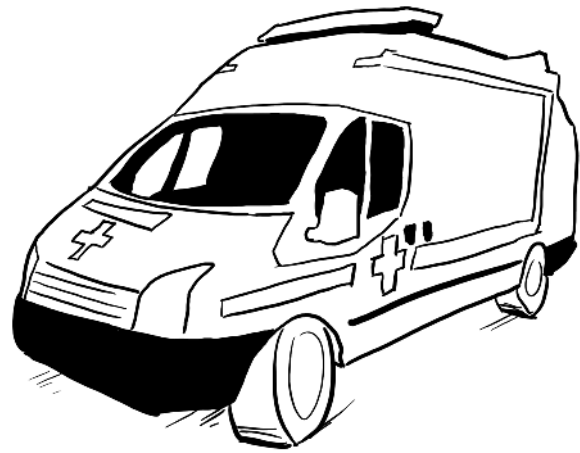

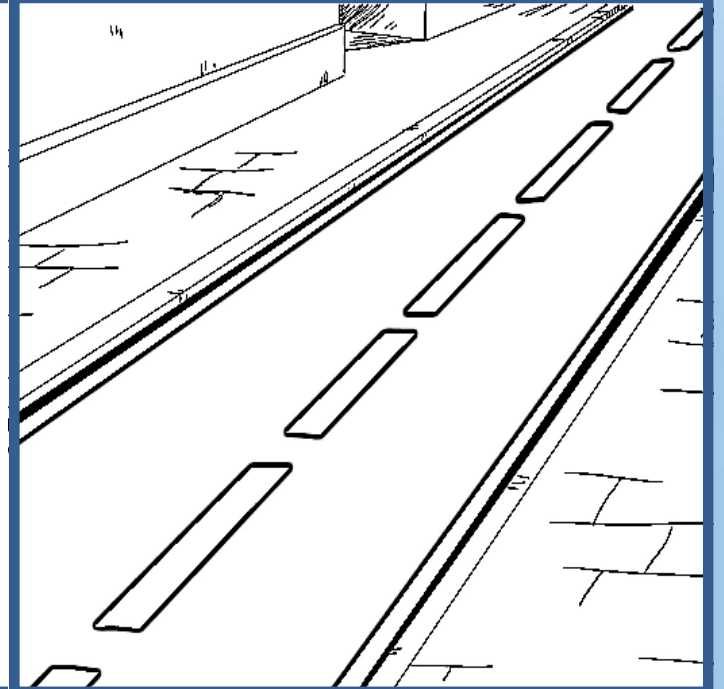
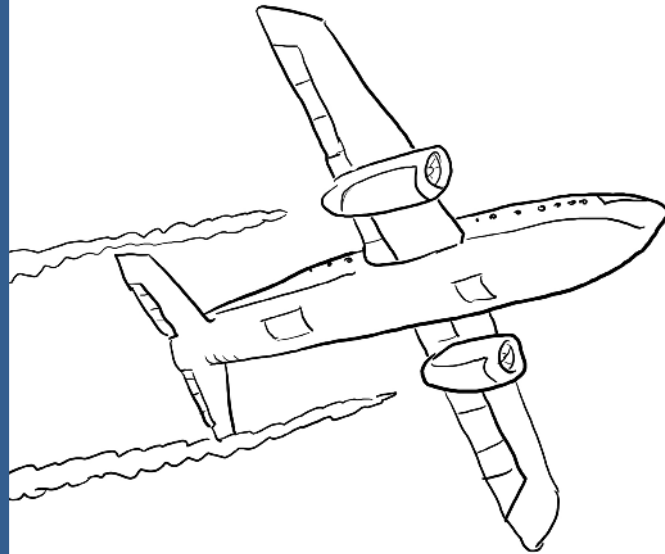
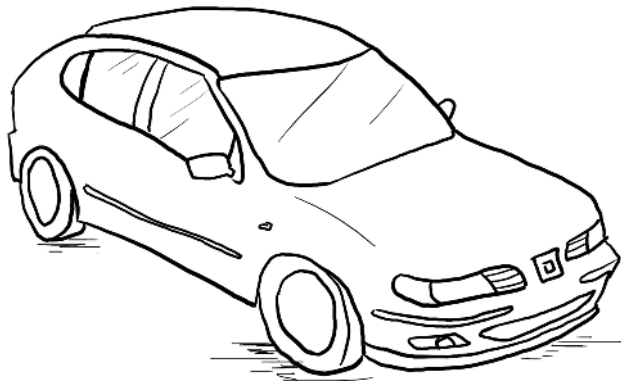
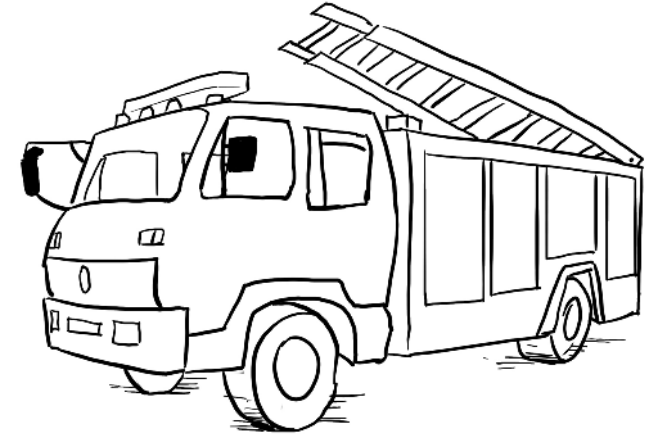
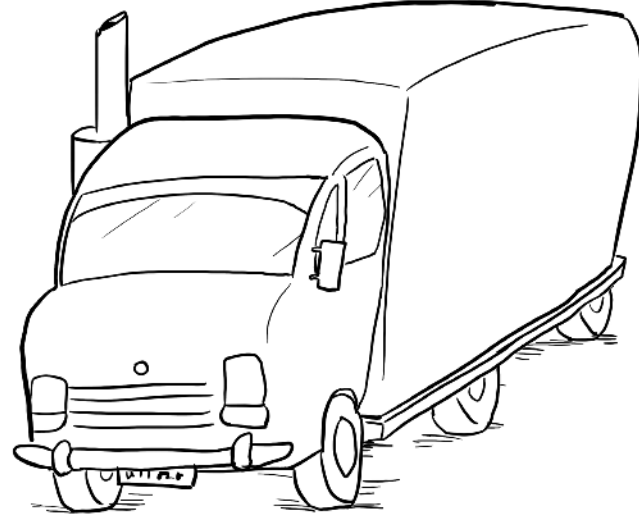
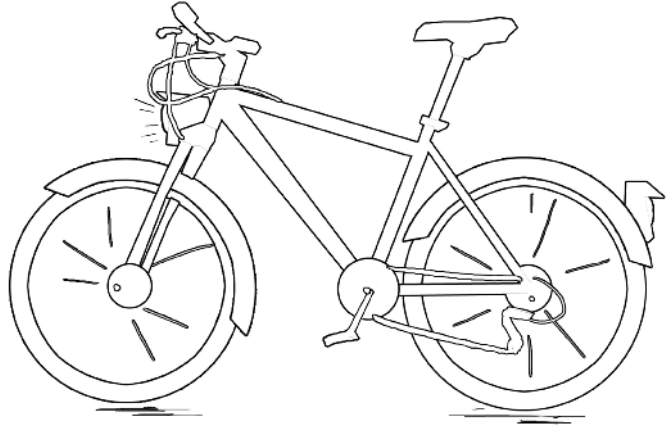

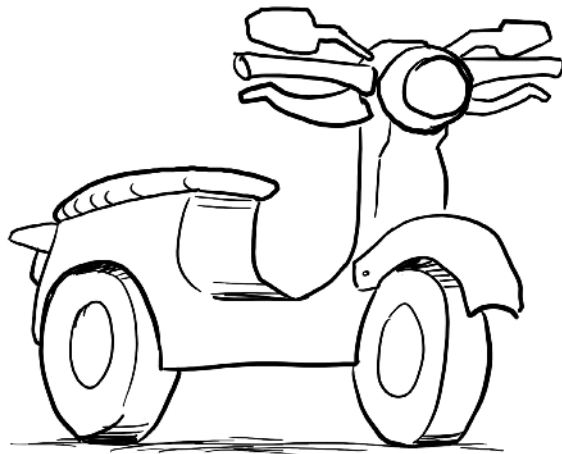
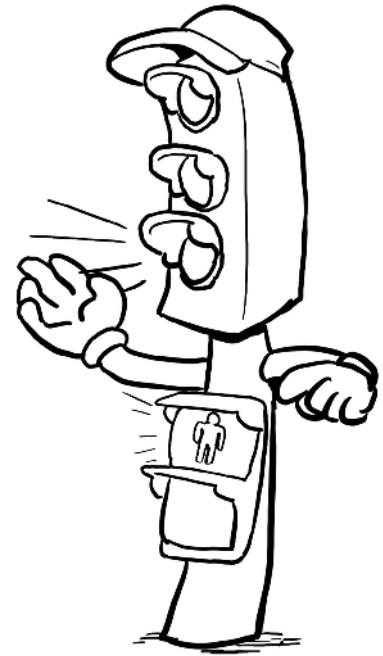

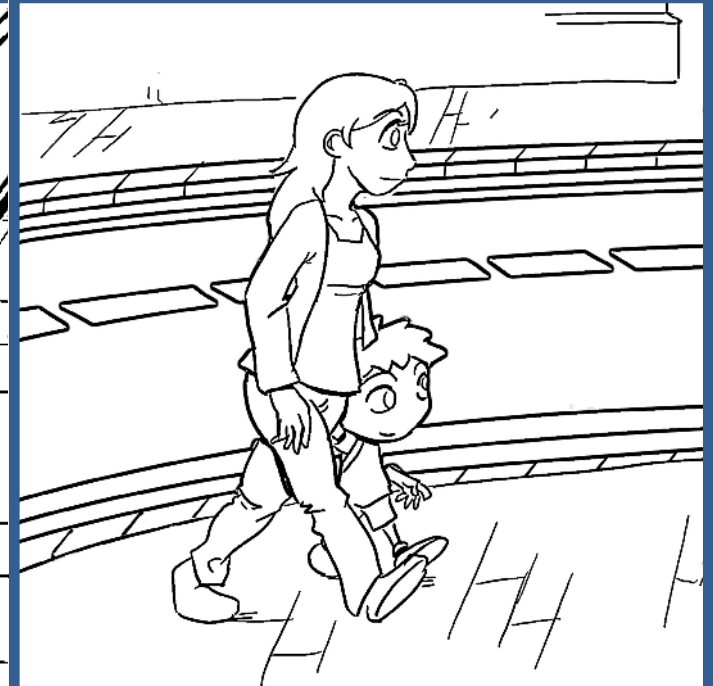
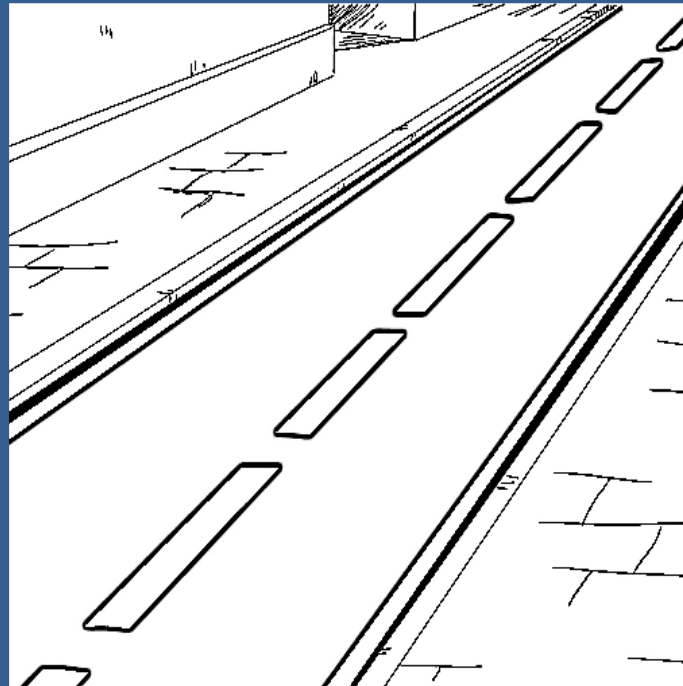
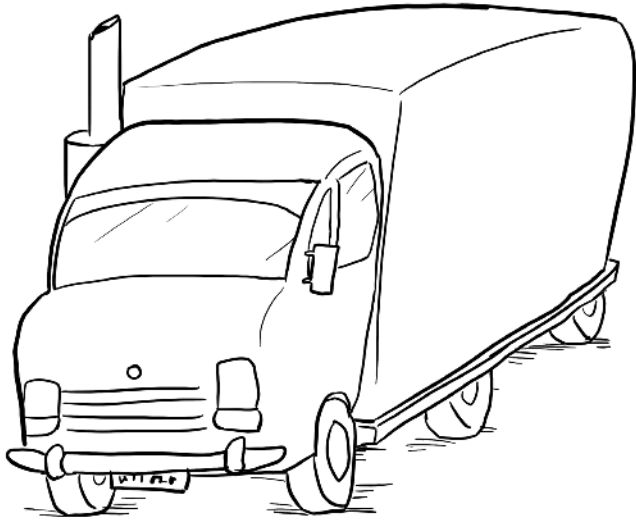

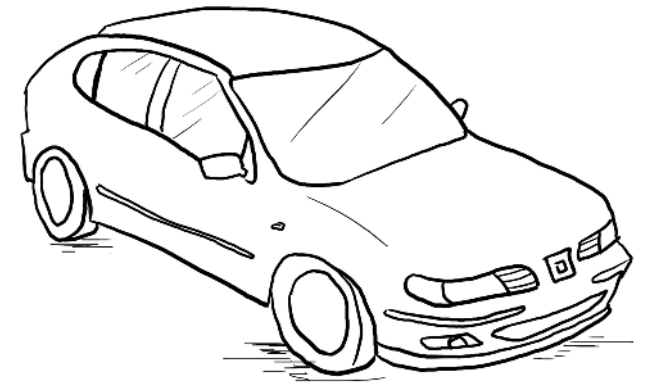
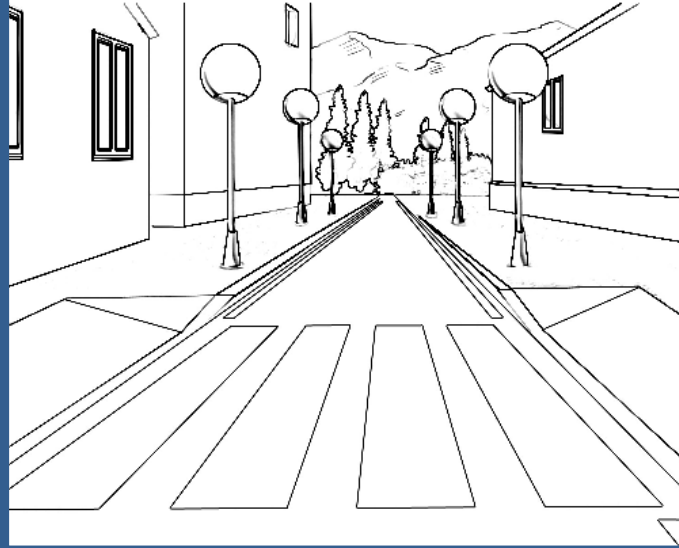
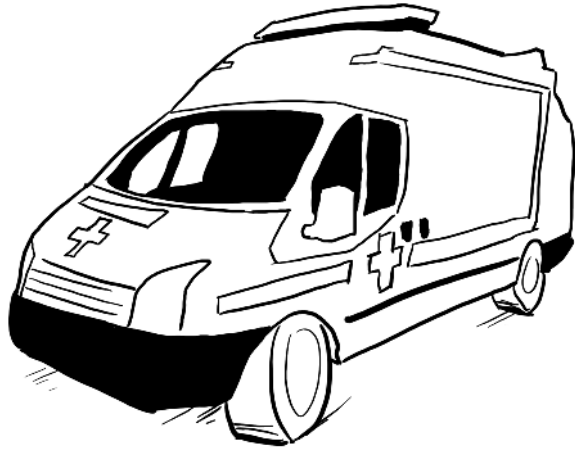
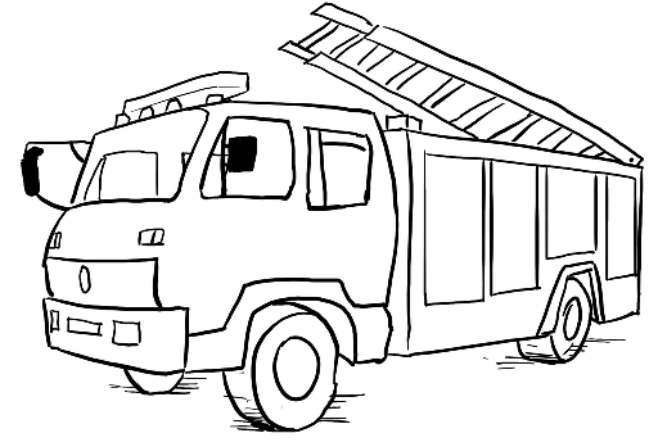
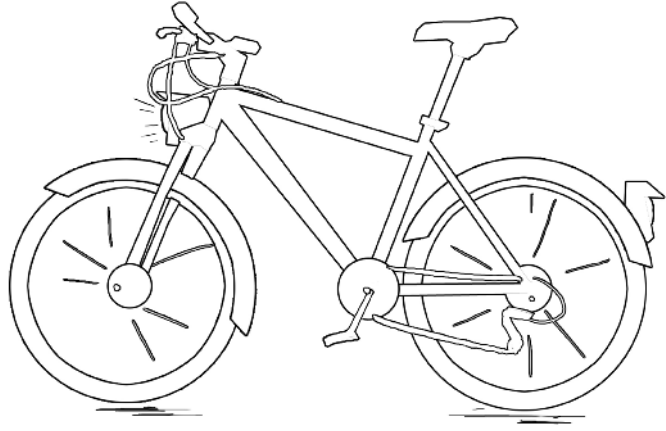

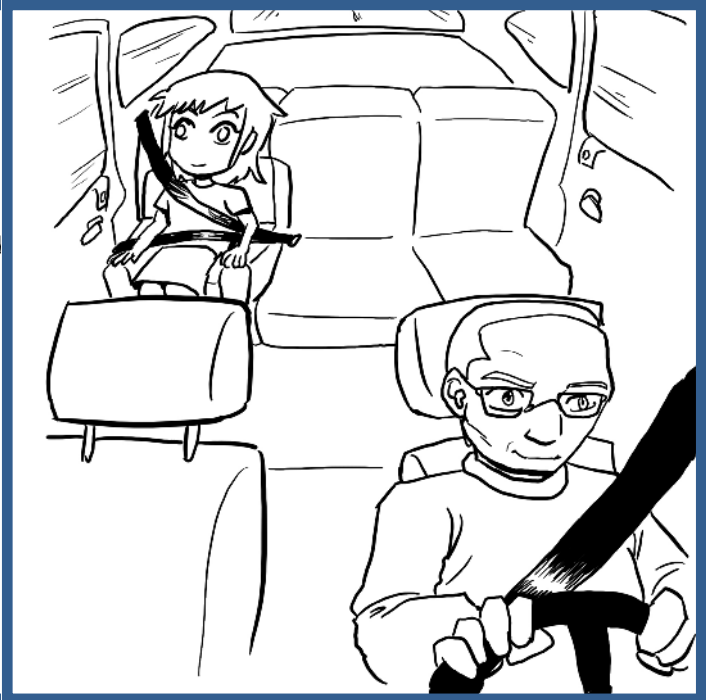
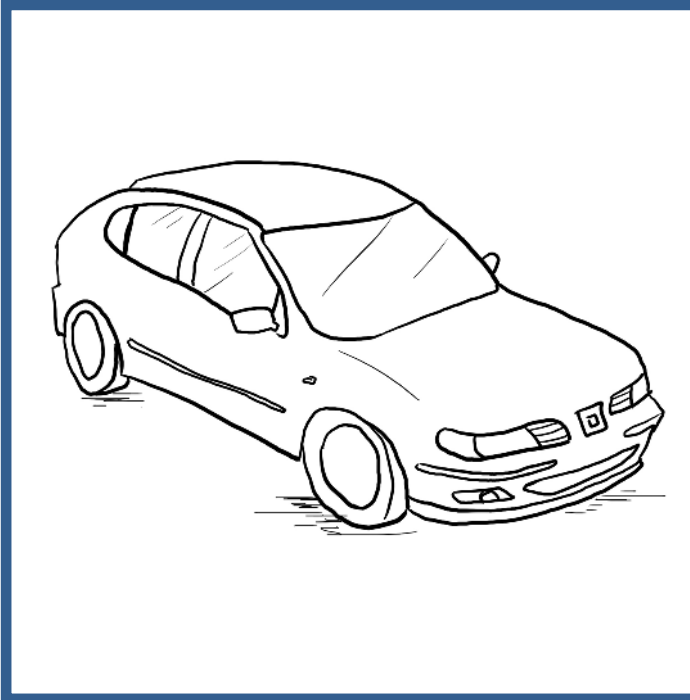
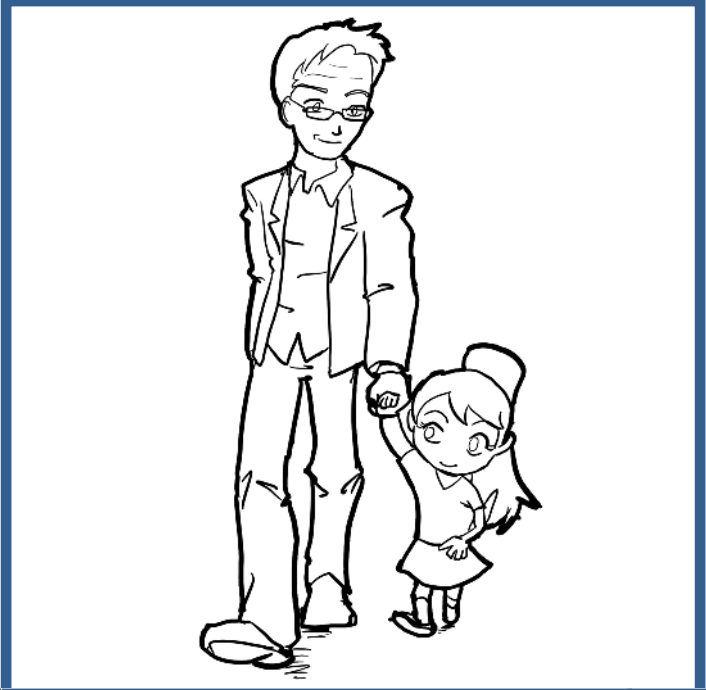
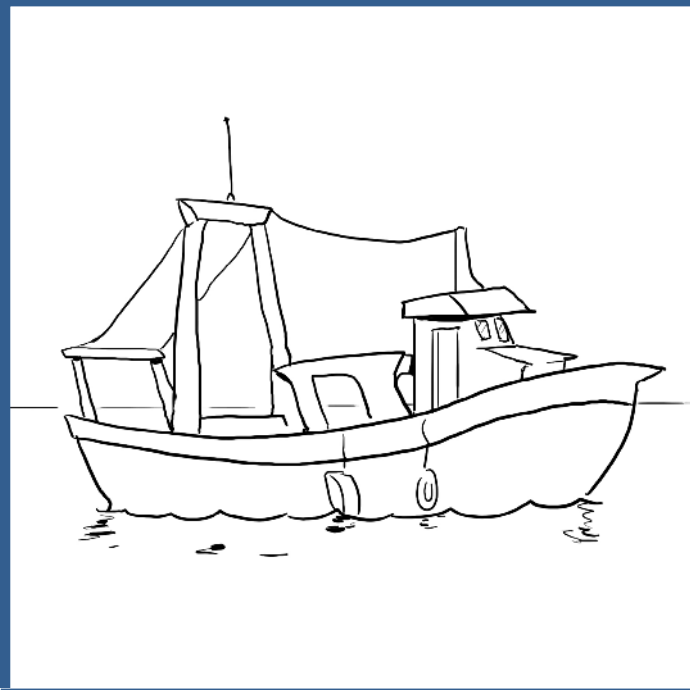



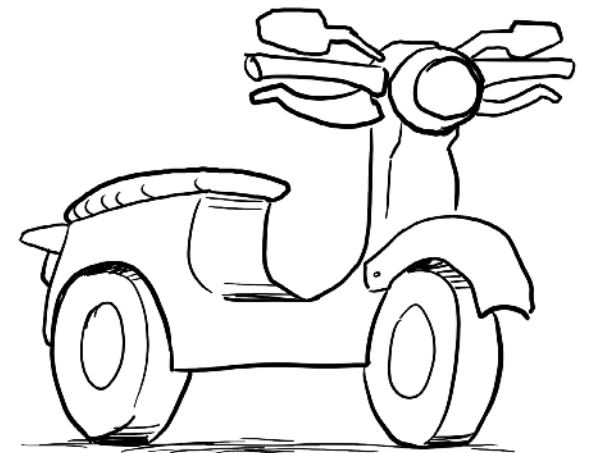
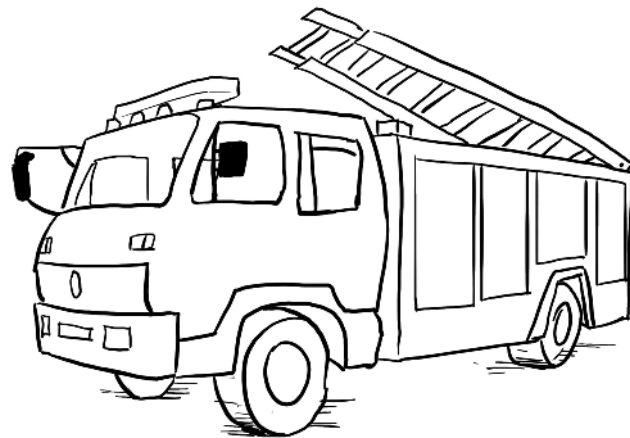
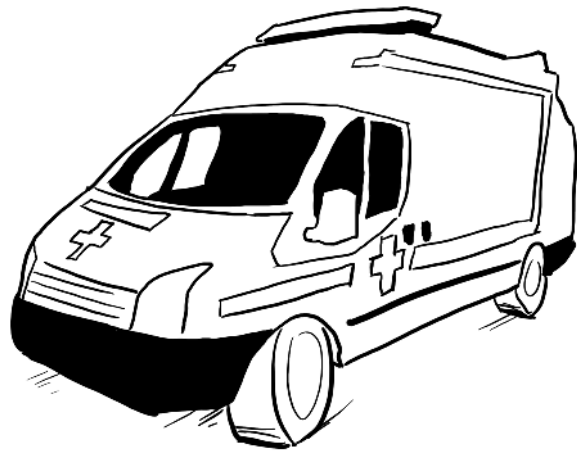
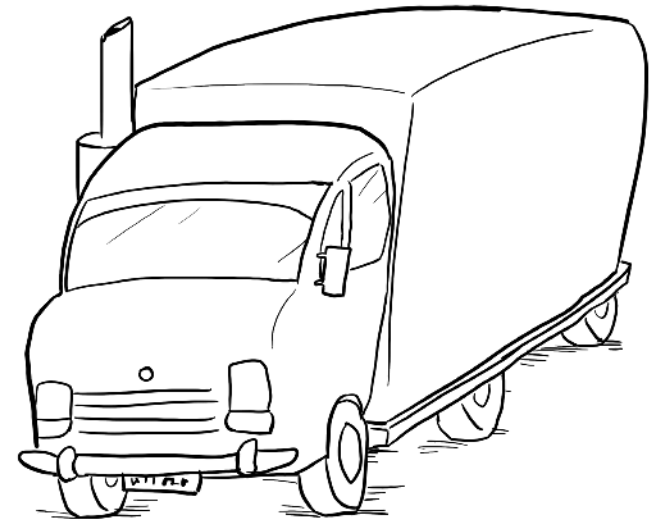
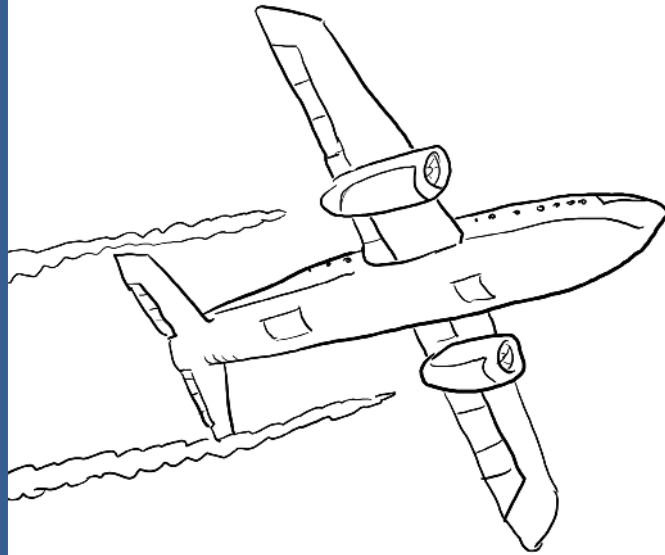

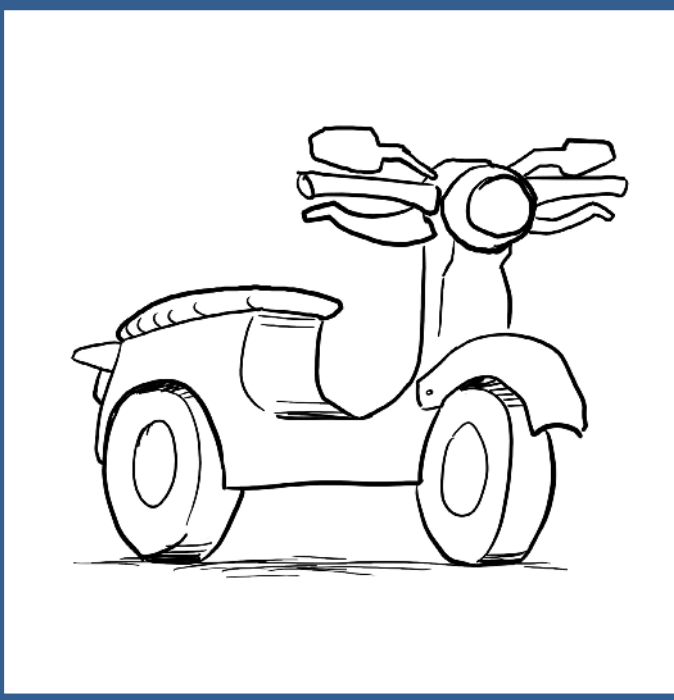
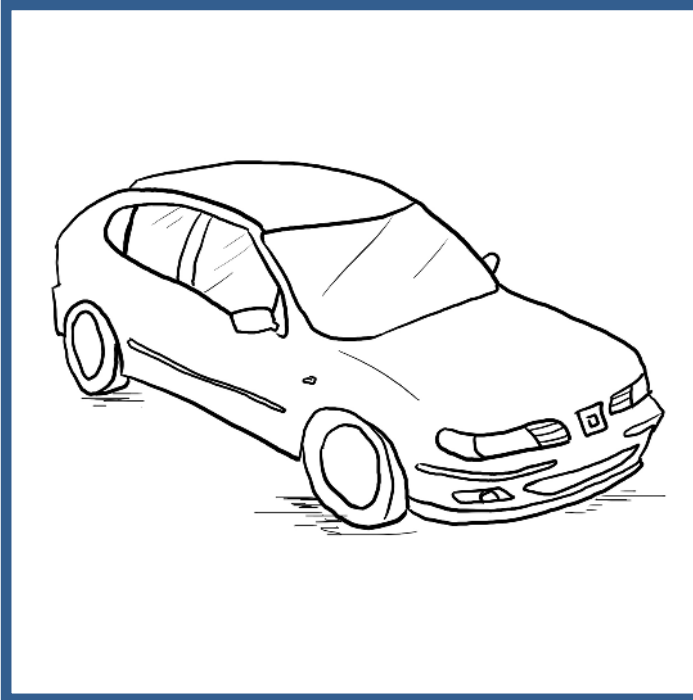

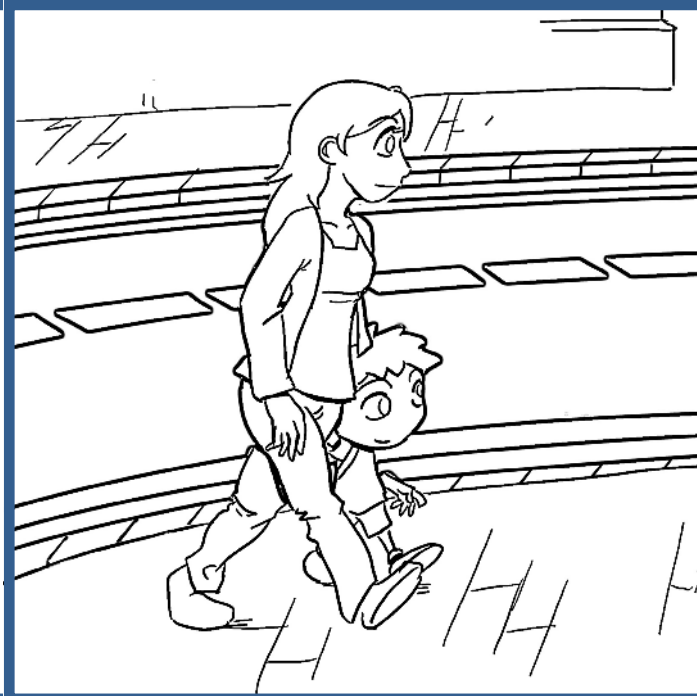
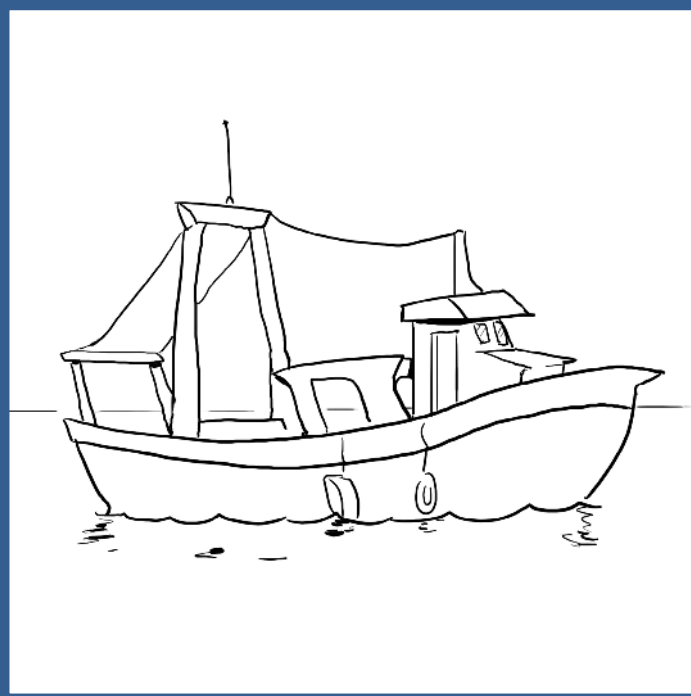
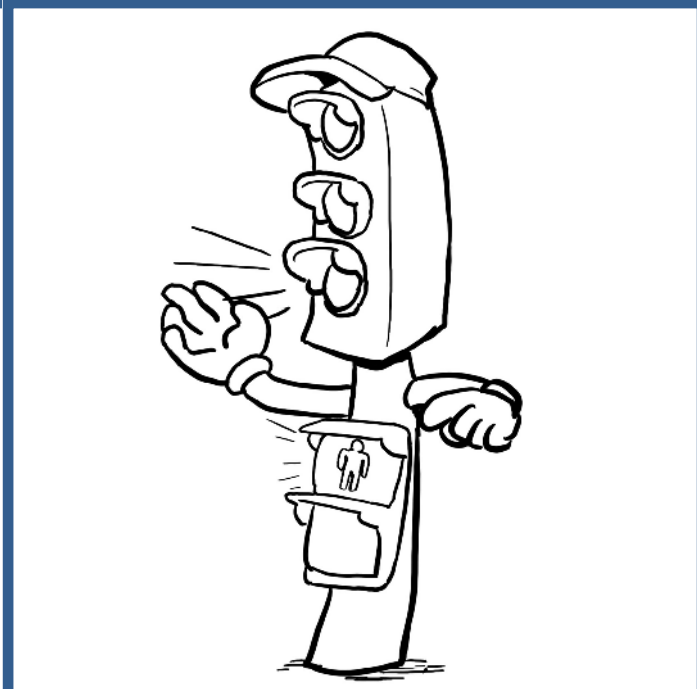
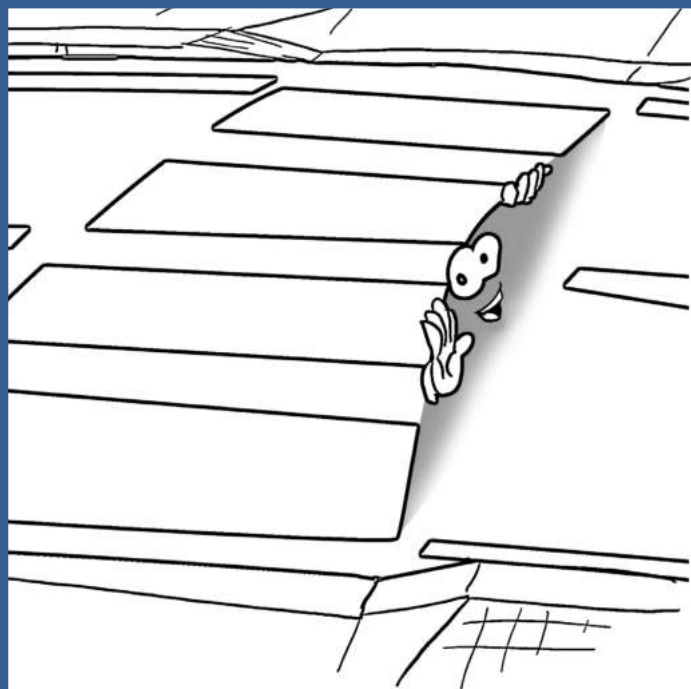

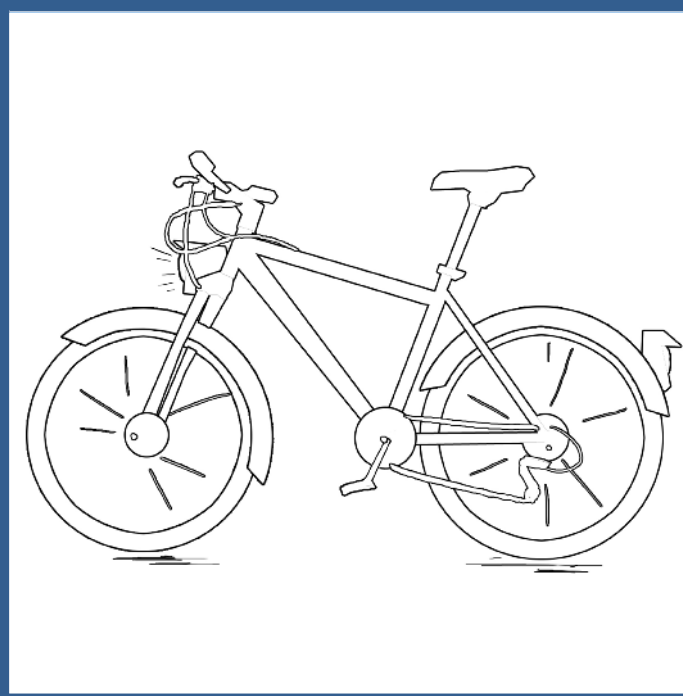
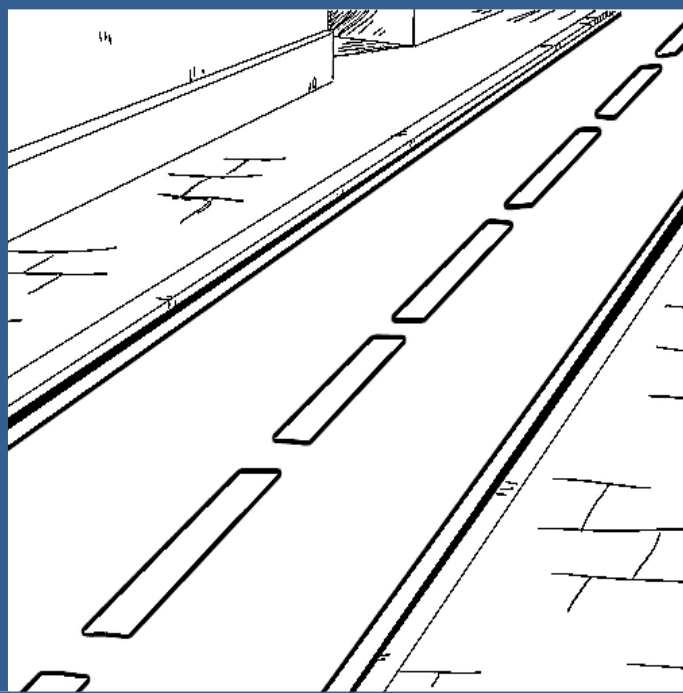
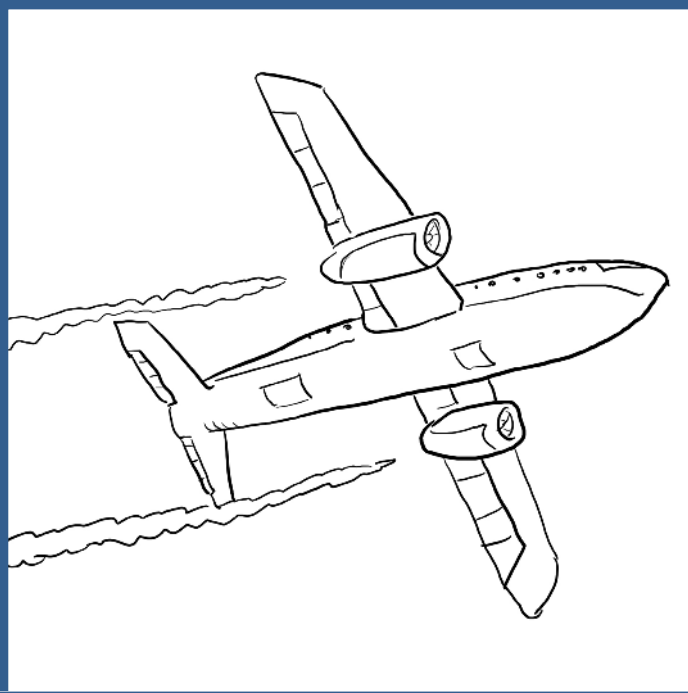

★ Recorta y colorea.

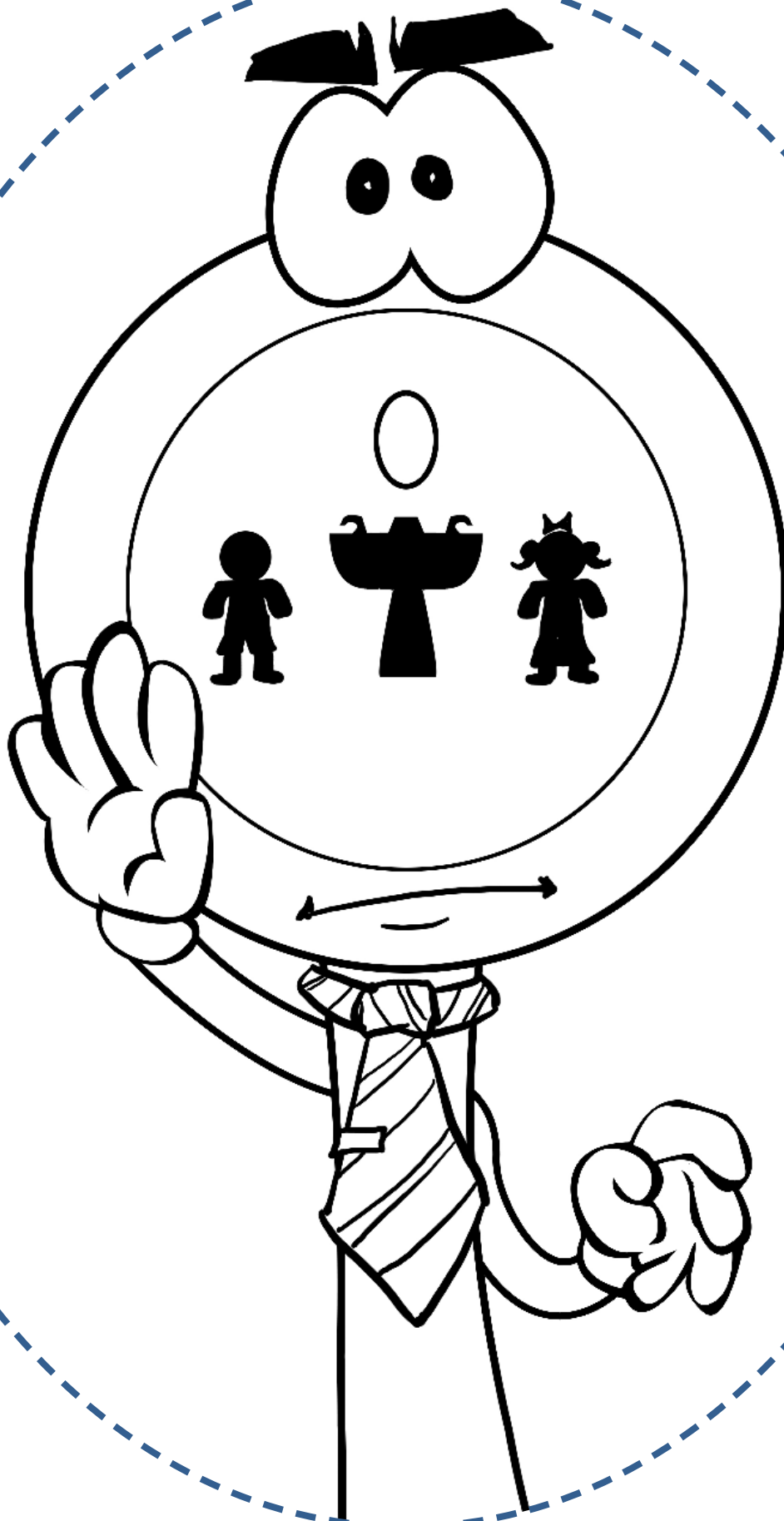

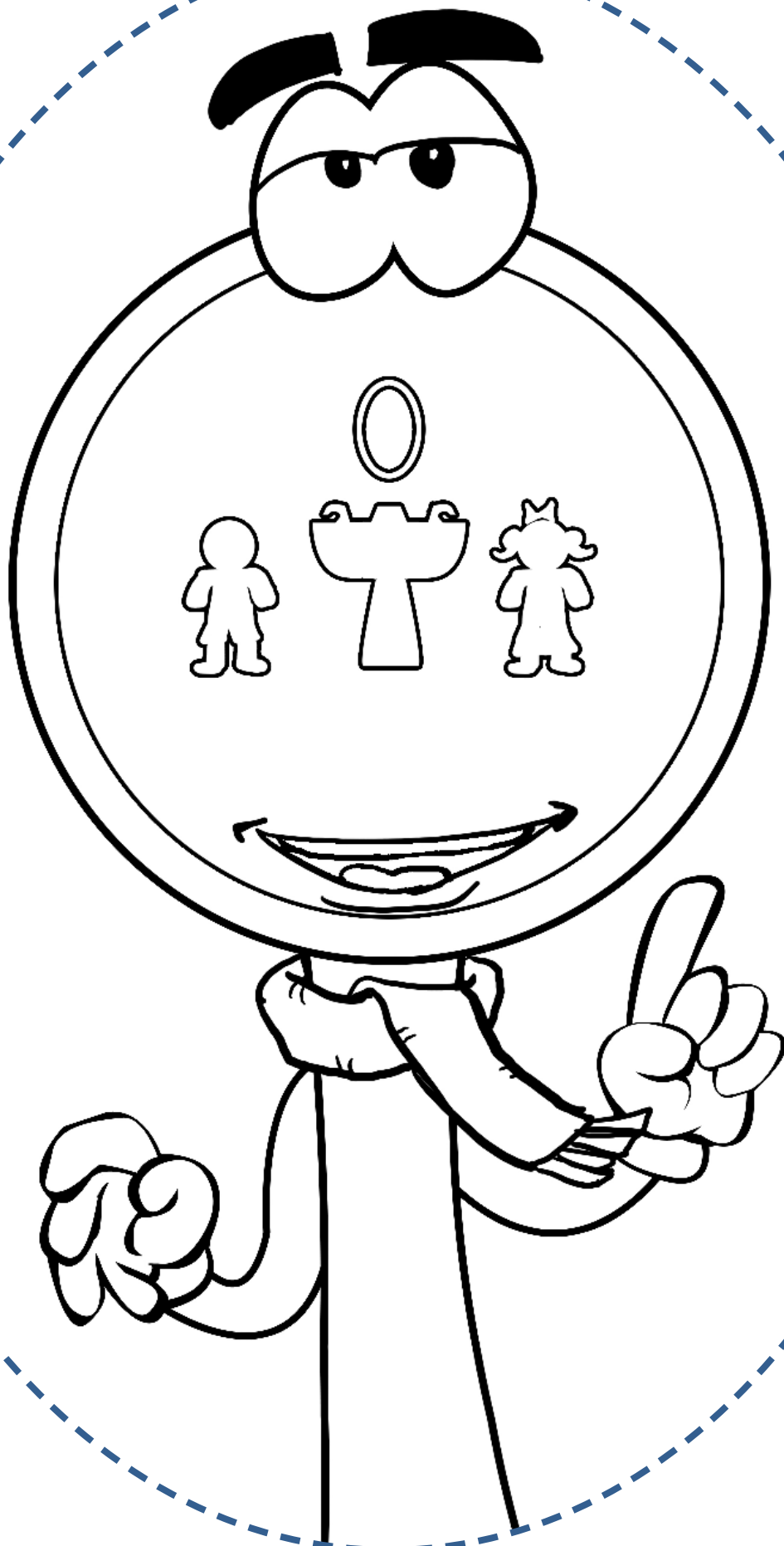

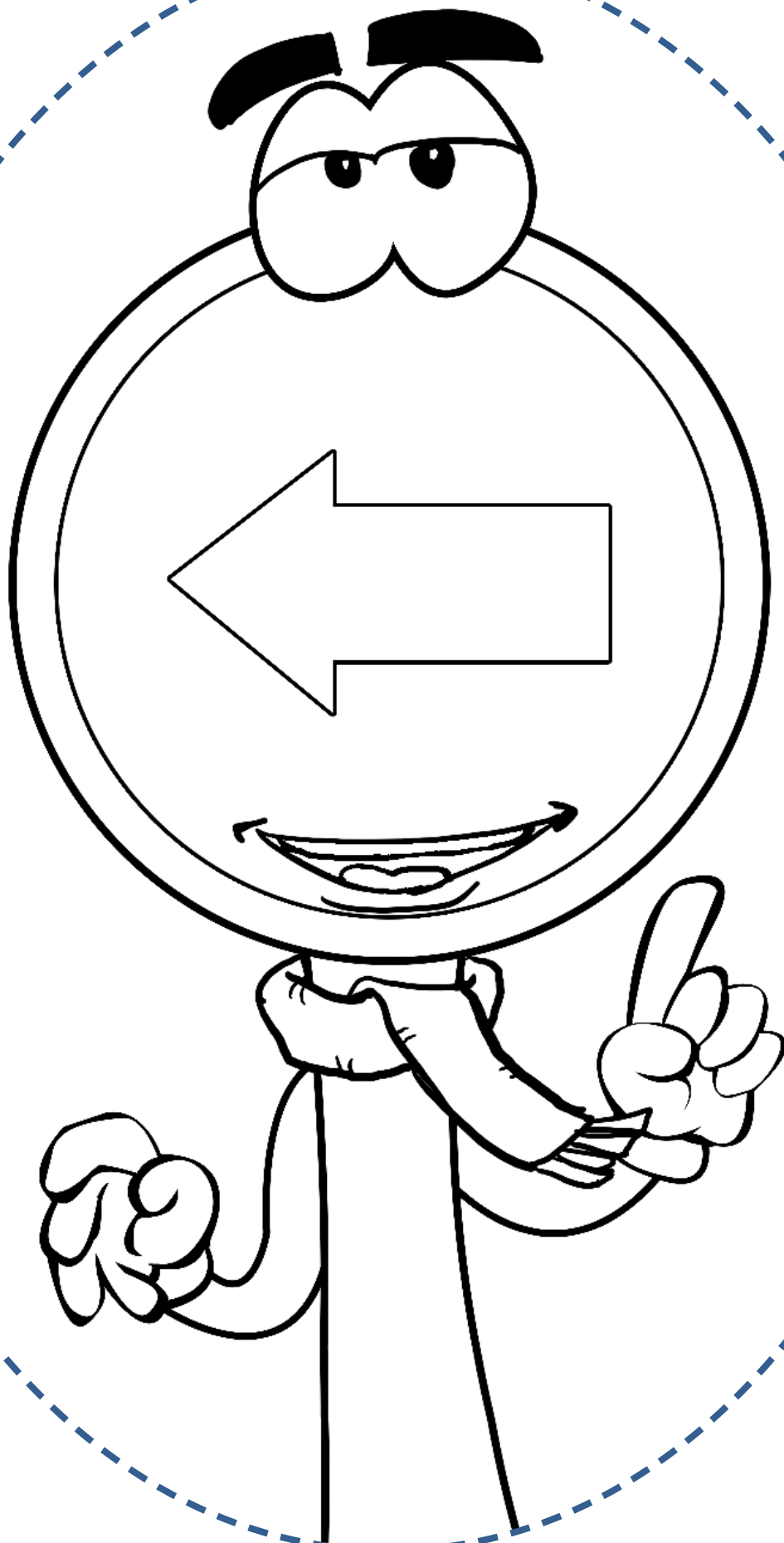

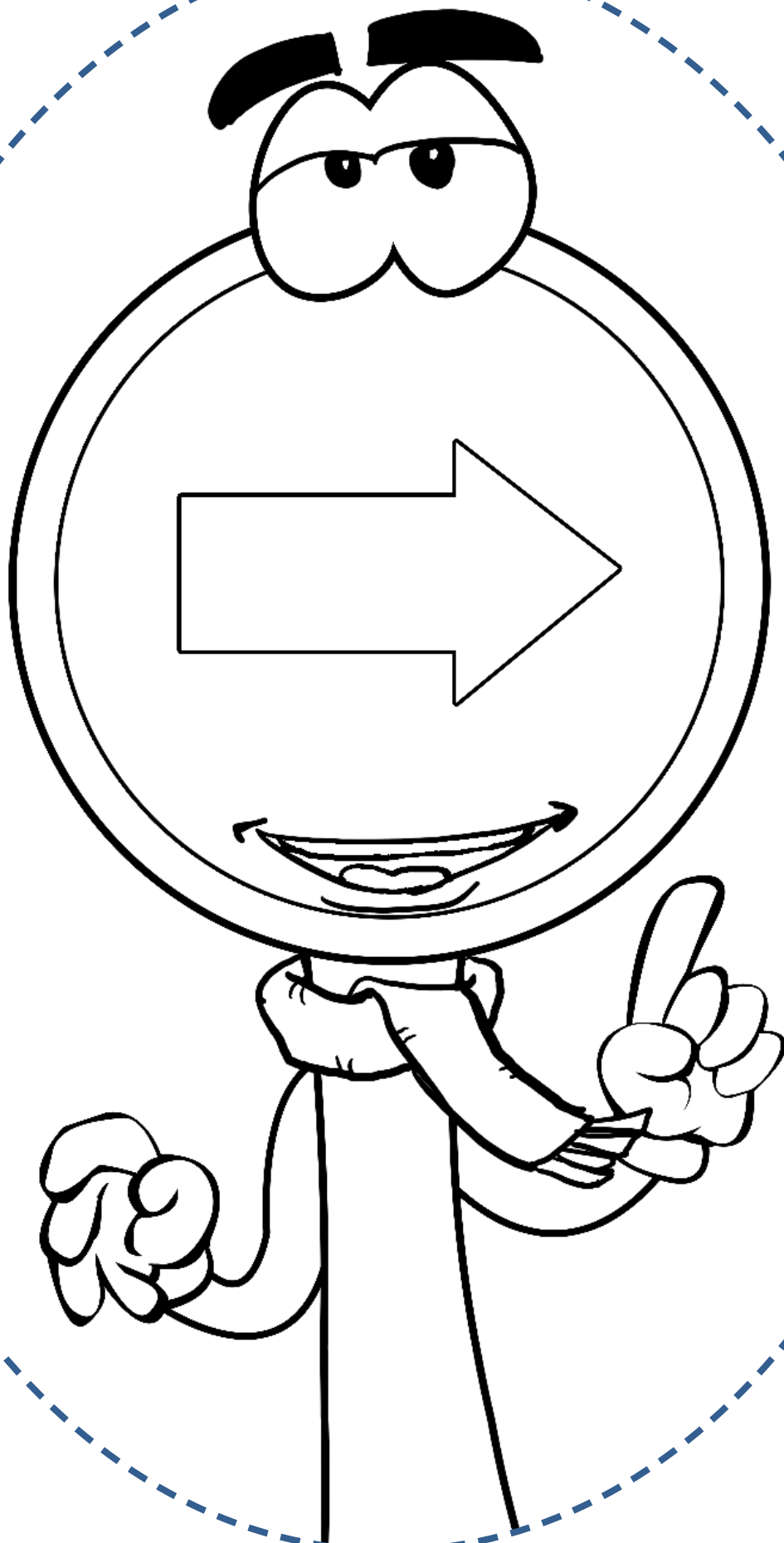







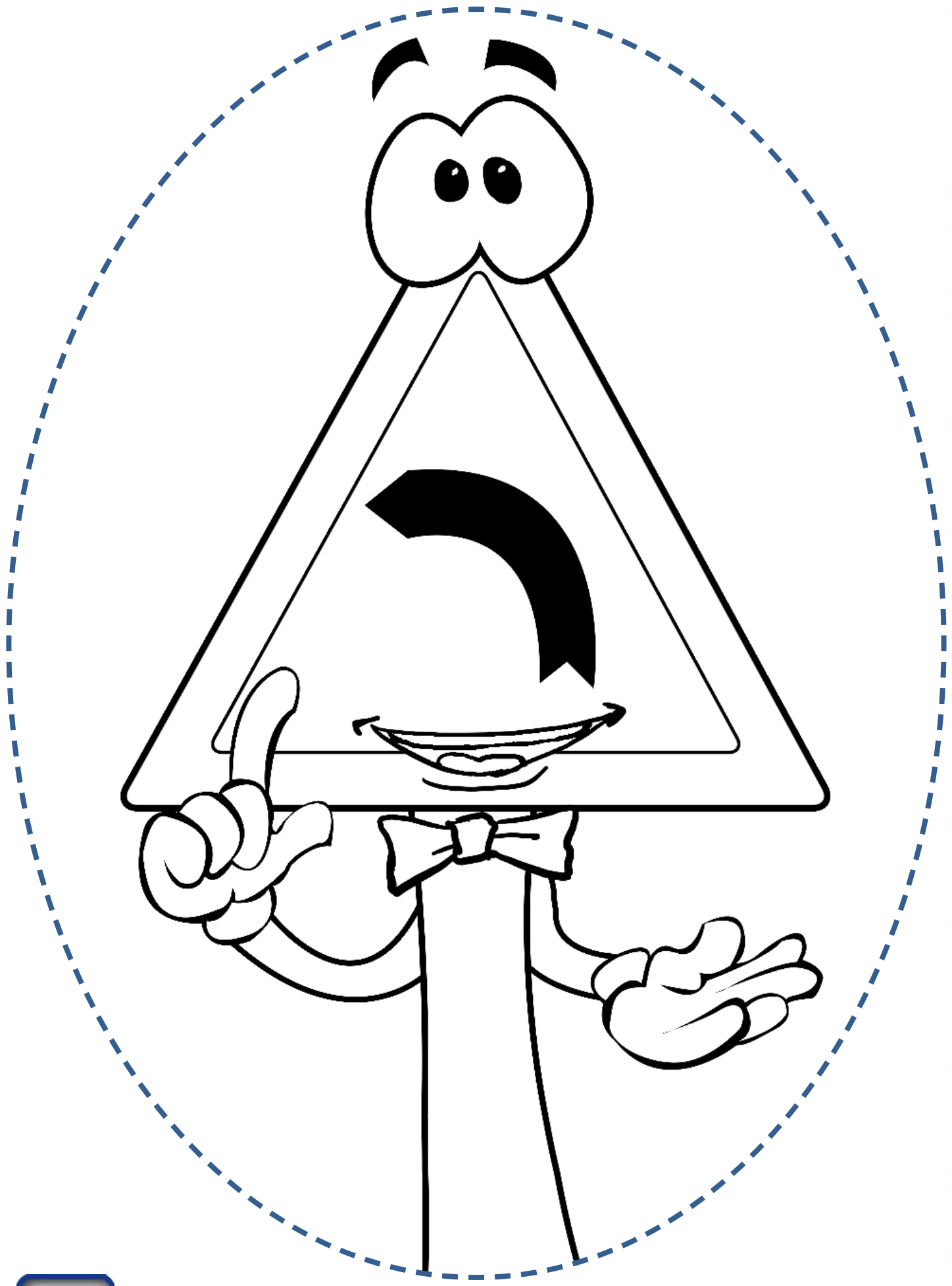

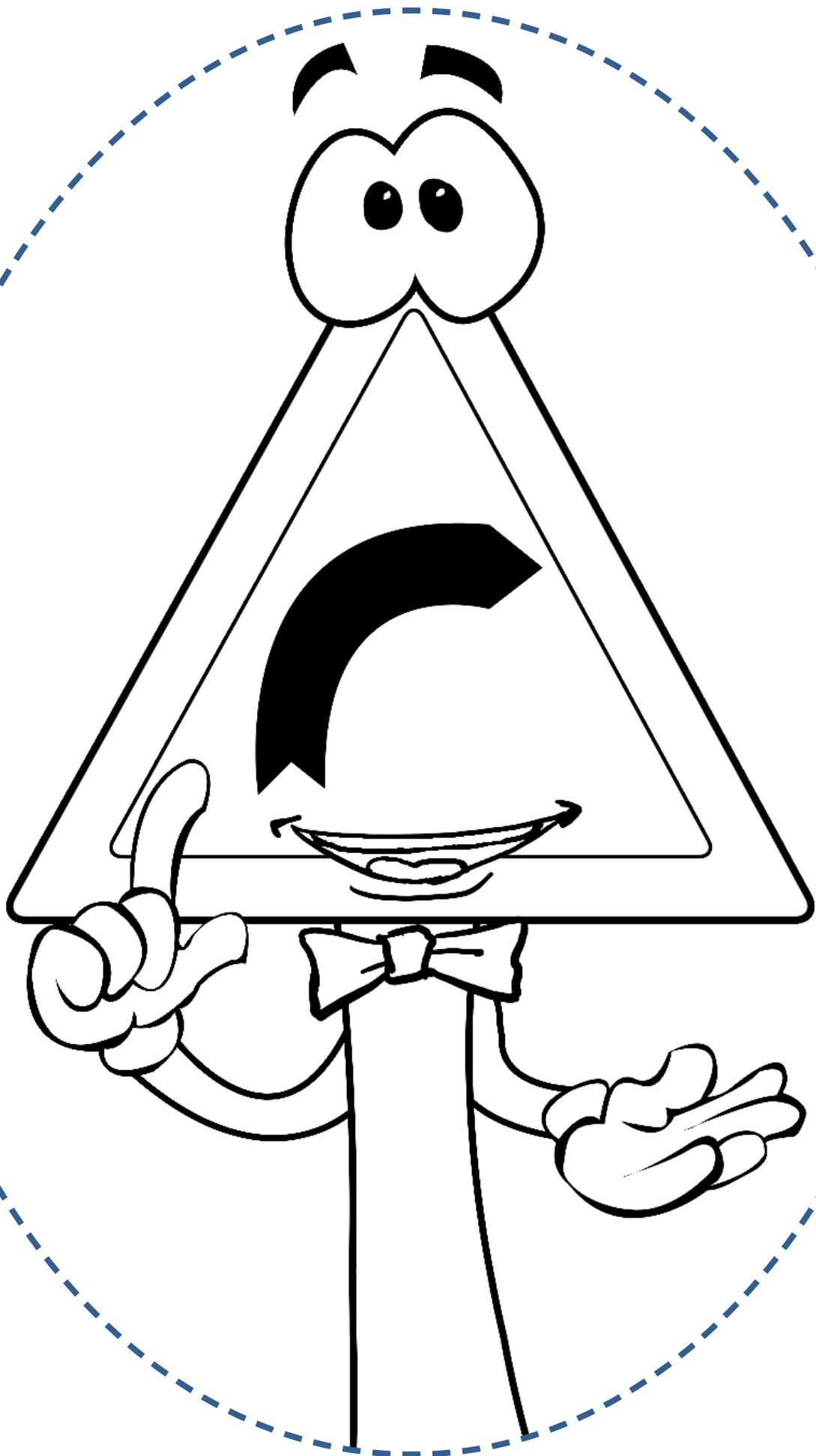

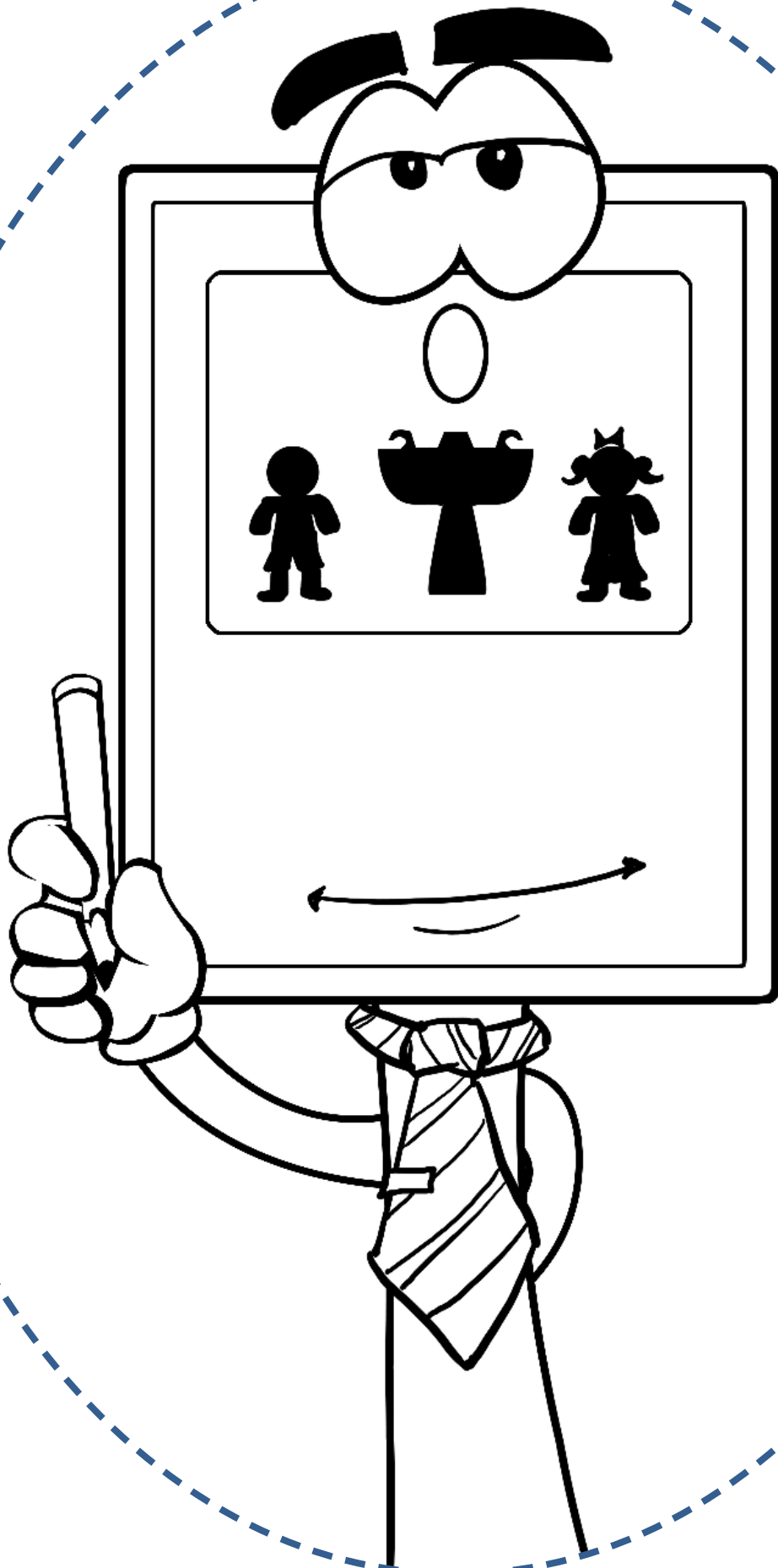

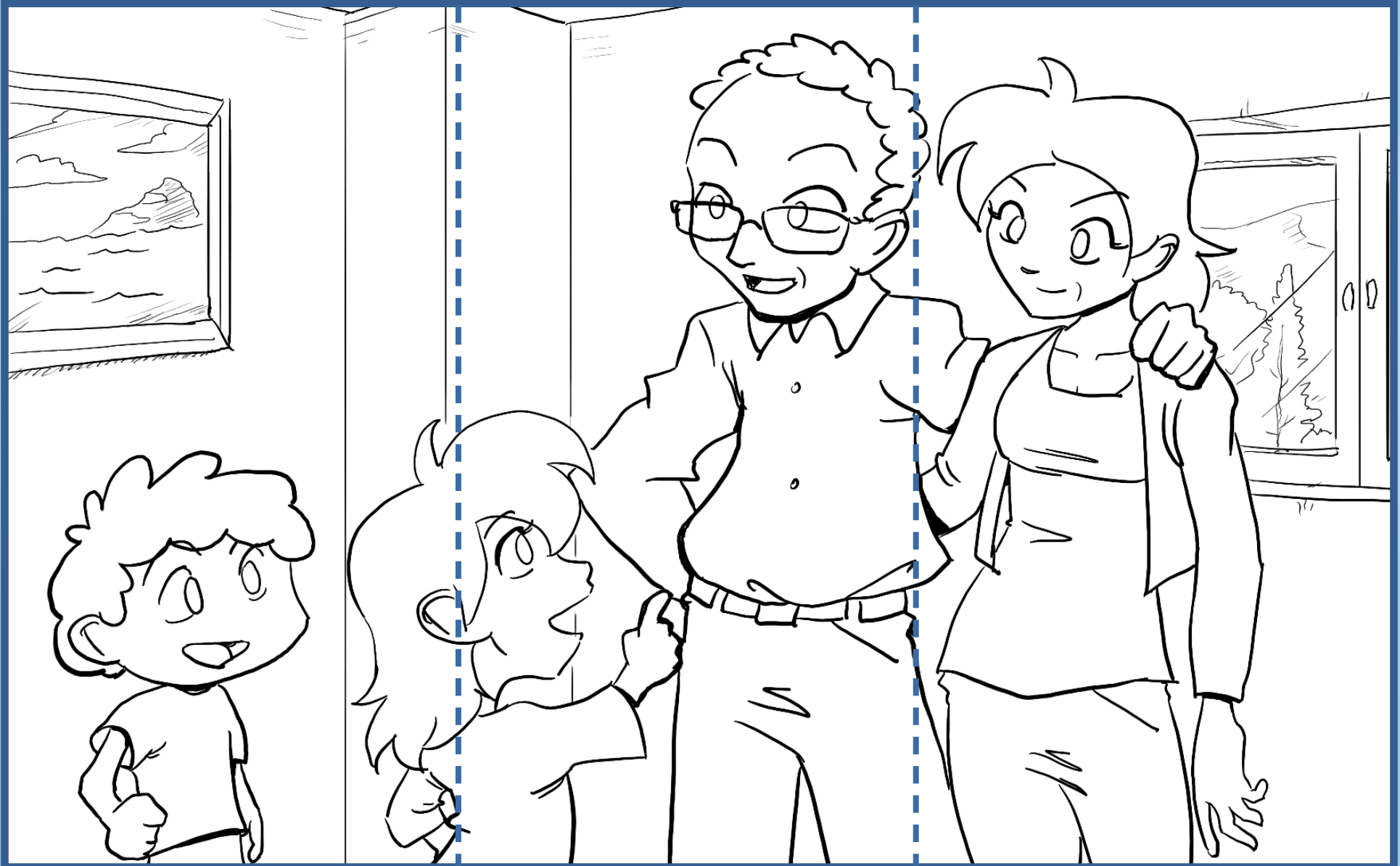

 **Recorta las piezas de la página anterior y monta el puzle en esta página.**

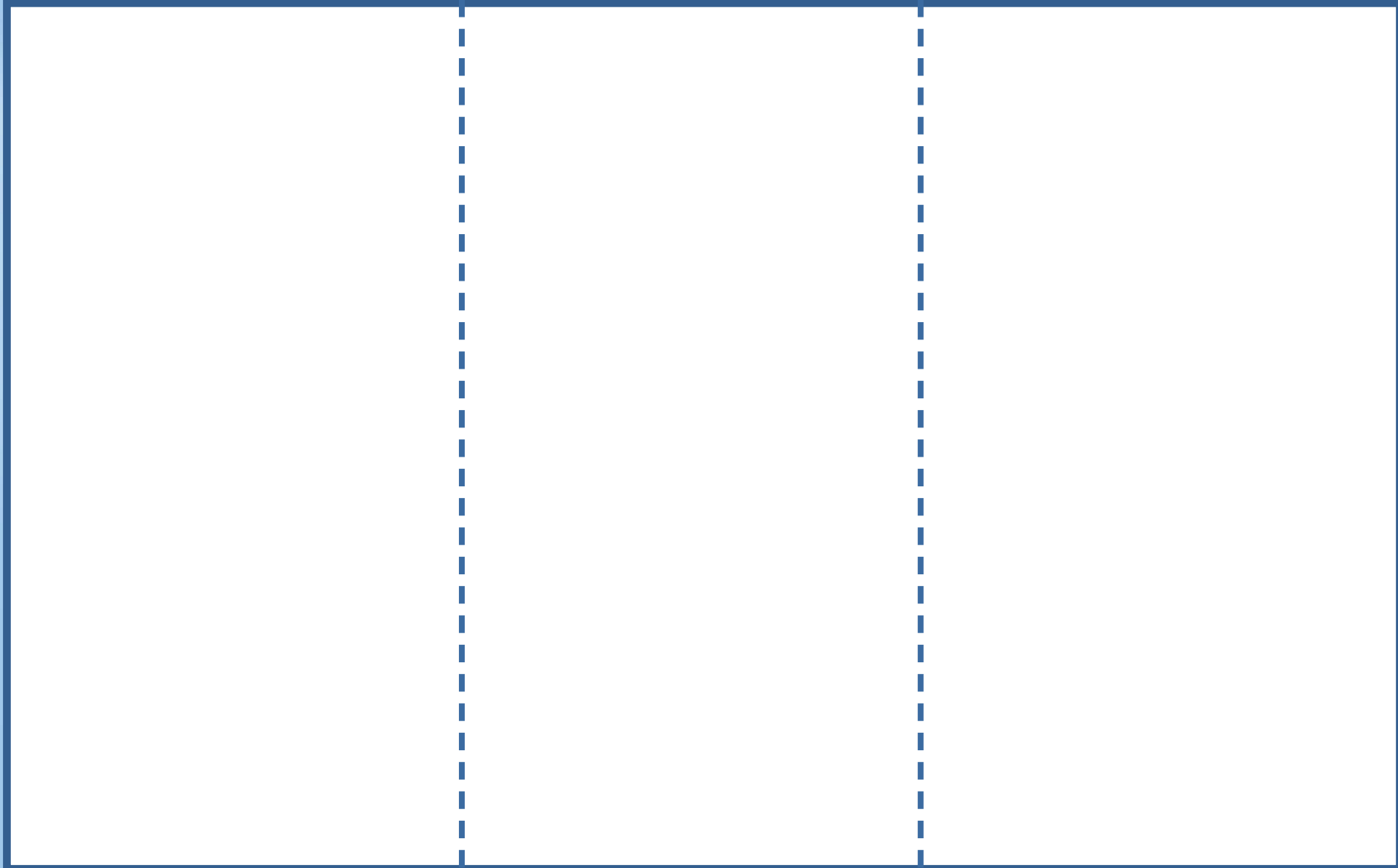

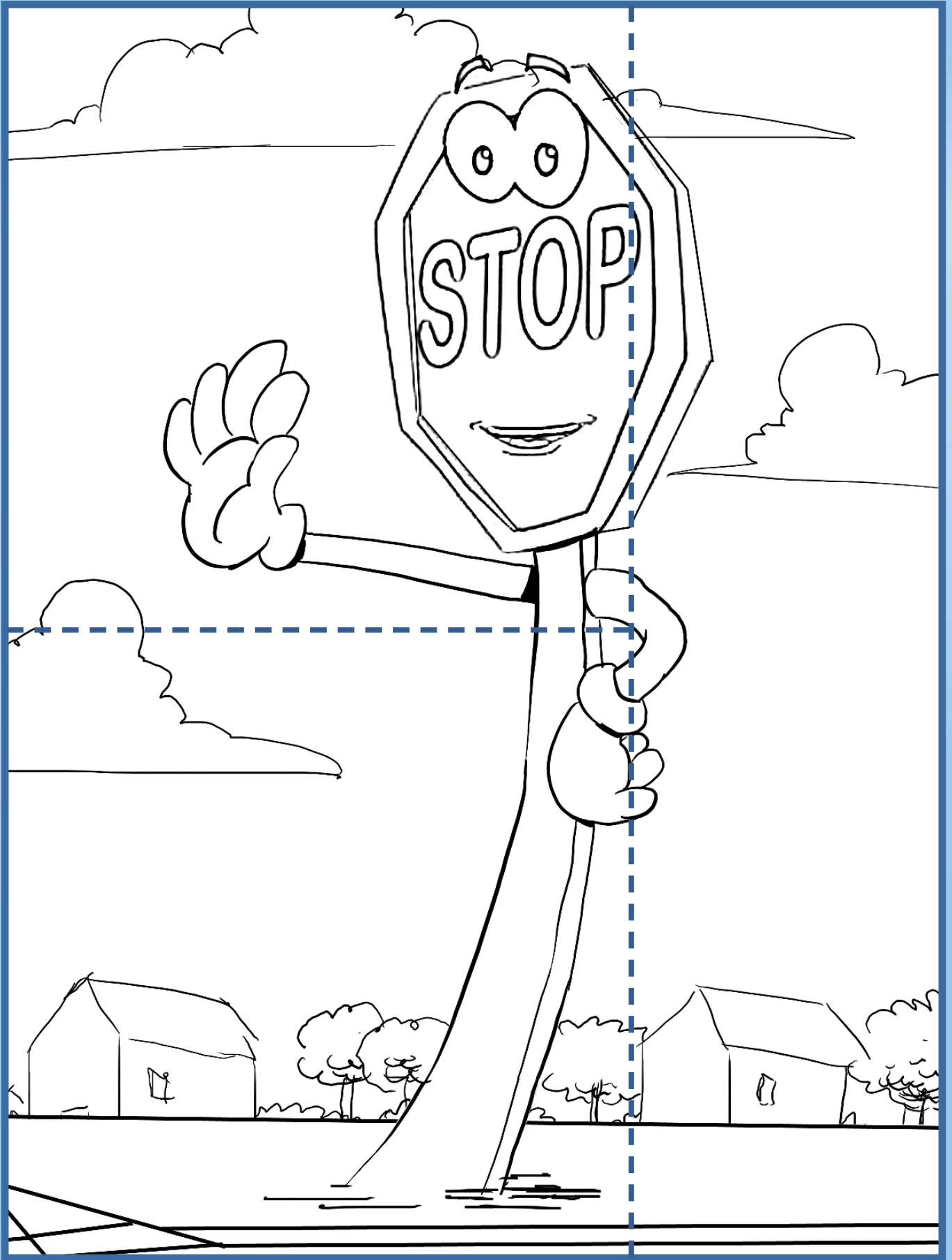





**Recorta las piezas de la página anterior y monta el puzle en esta página.**

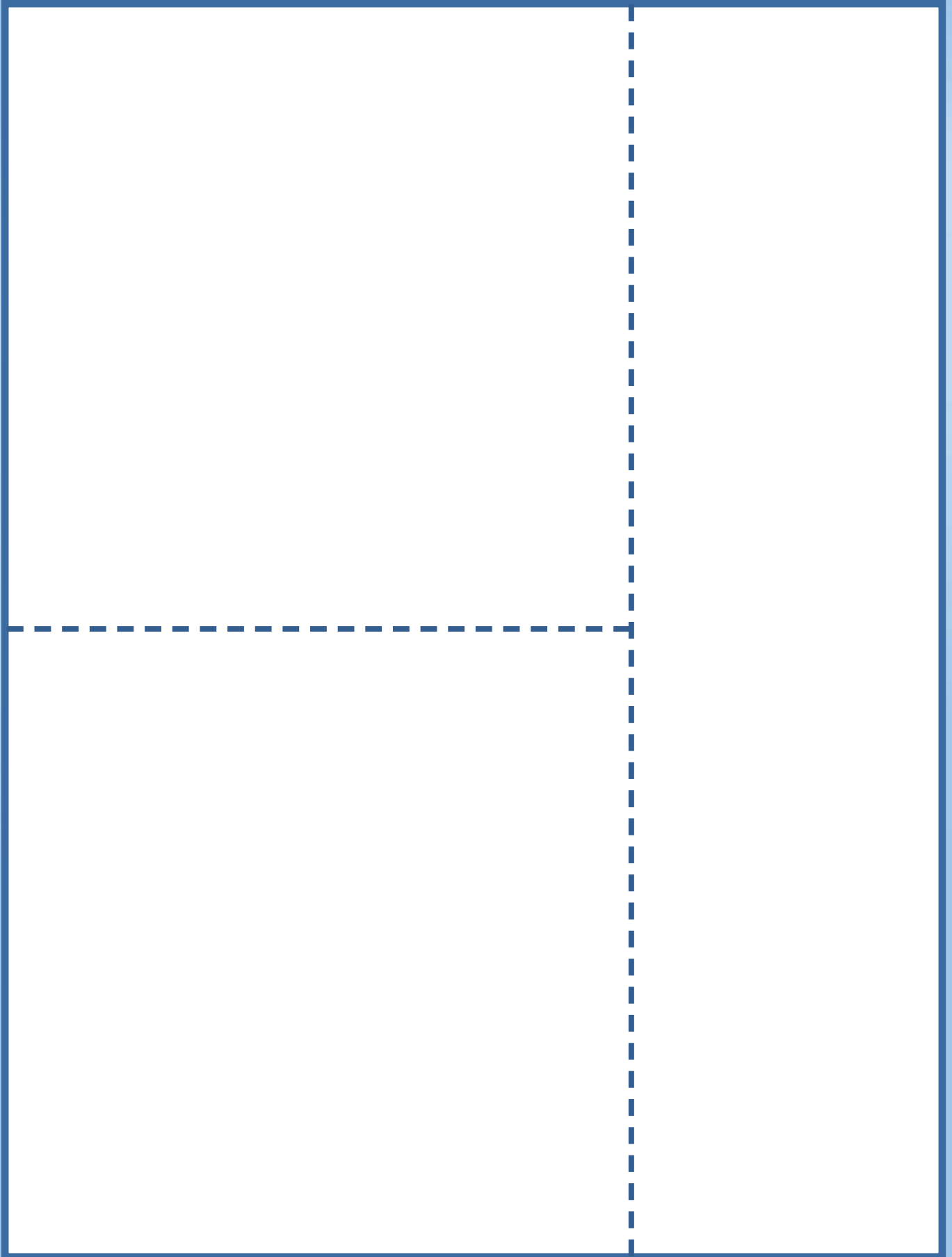

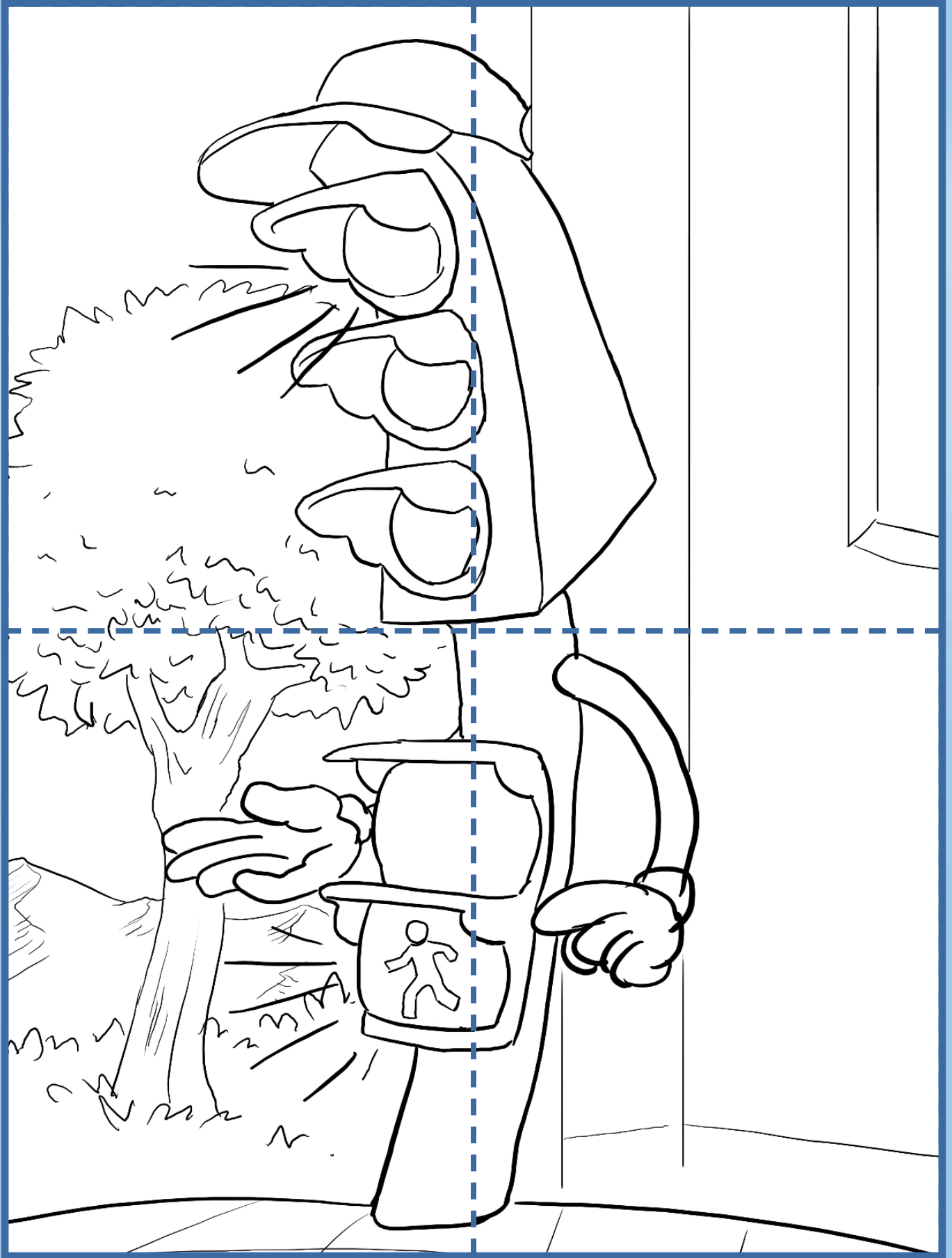



**Recorta las piezas de la página anterior y monta el puzle en esta página.**

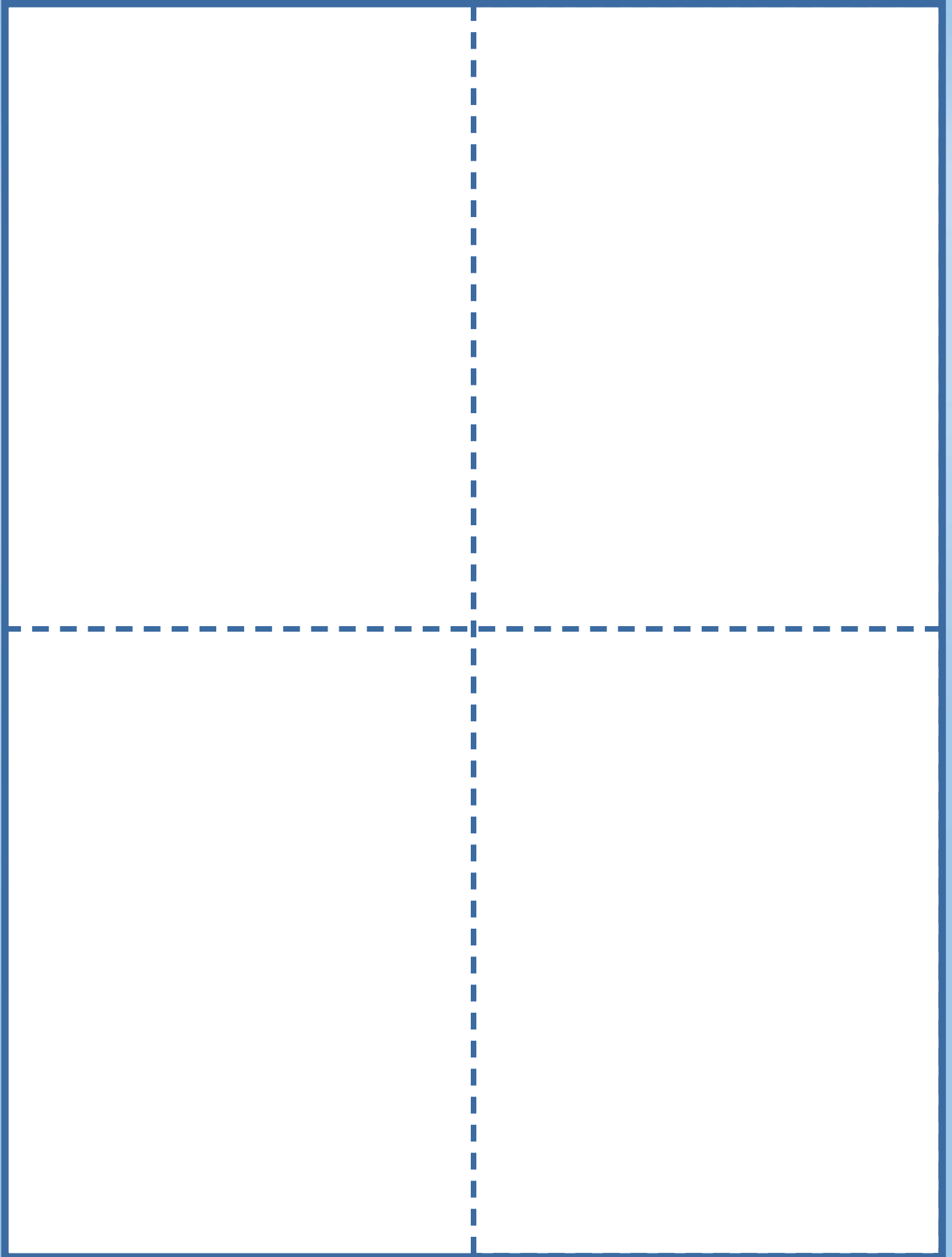

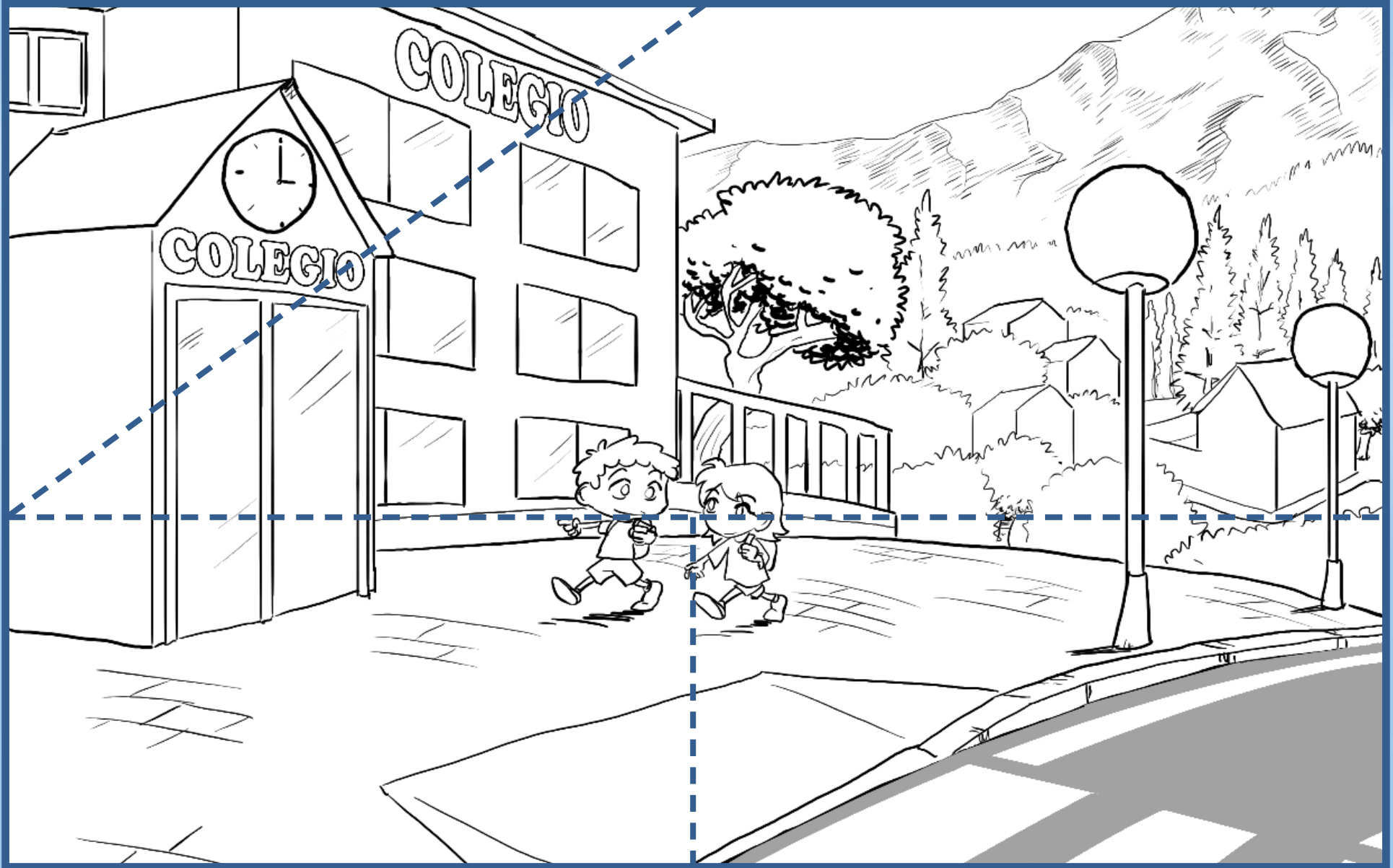

★ Recorta las piezas de la página anterior y monta el puzle en esta página.

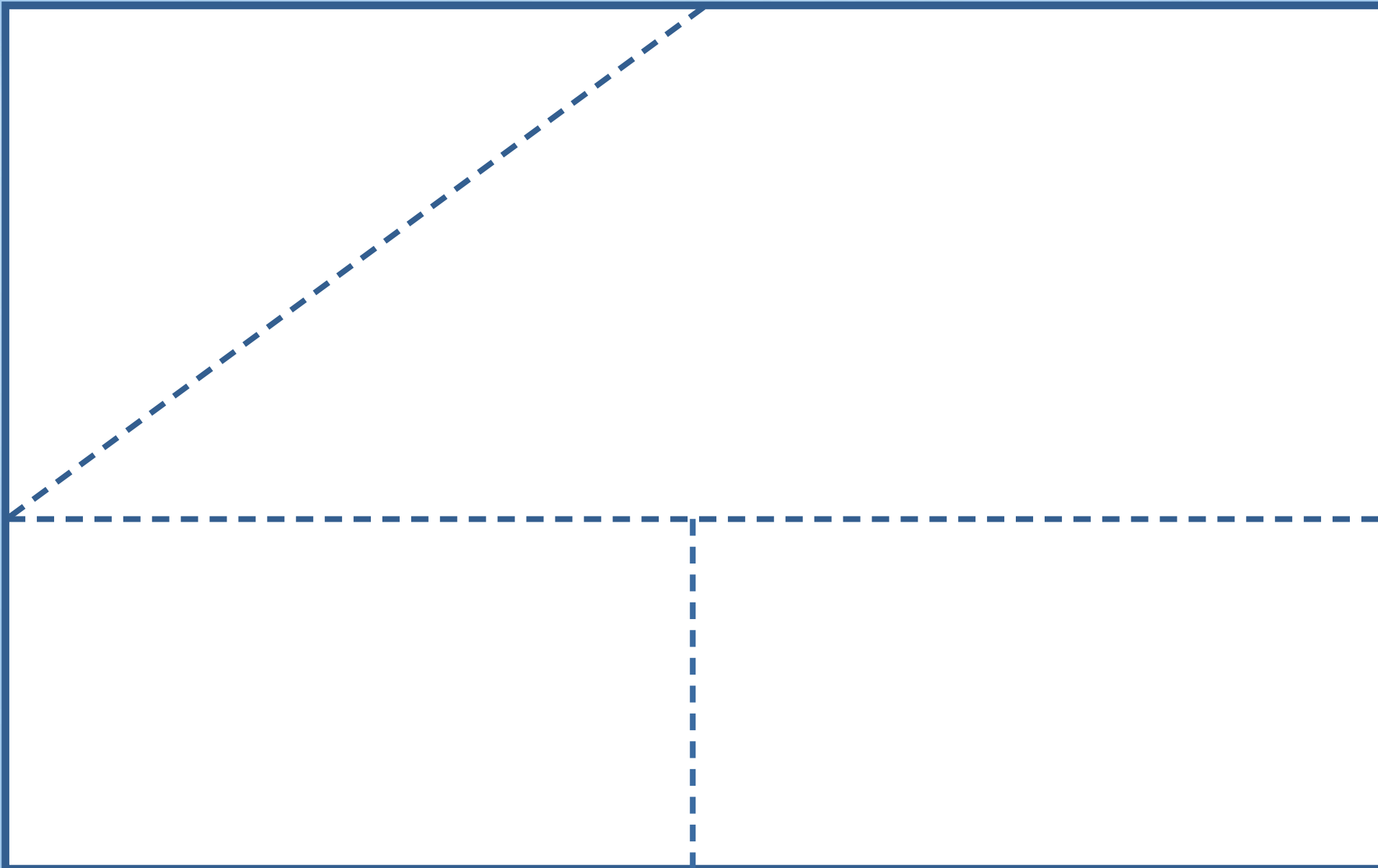

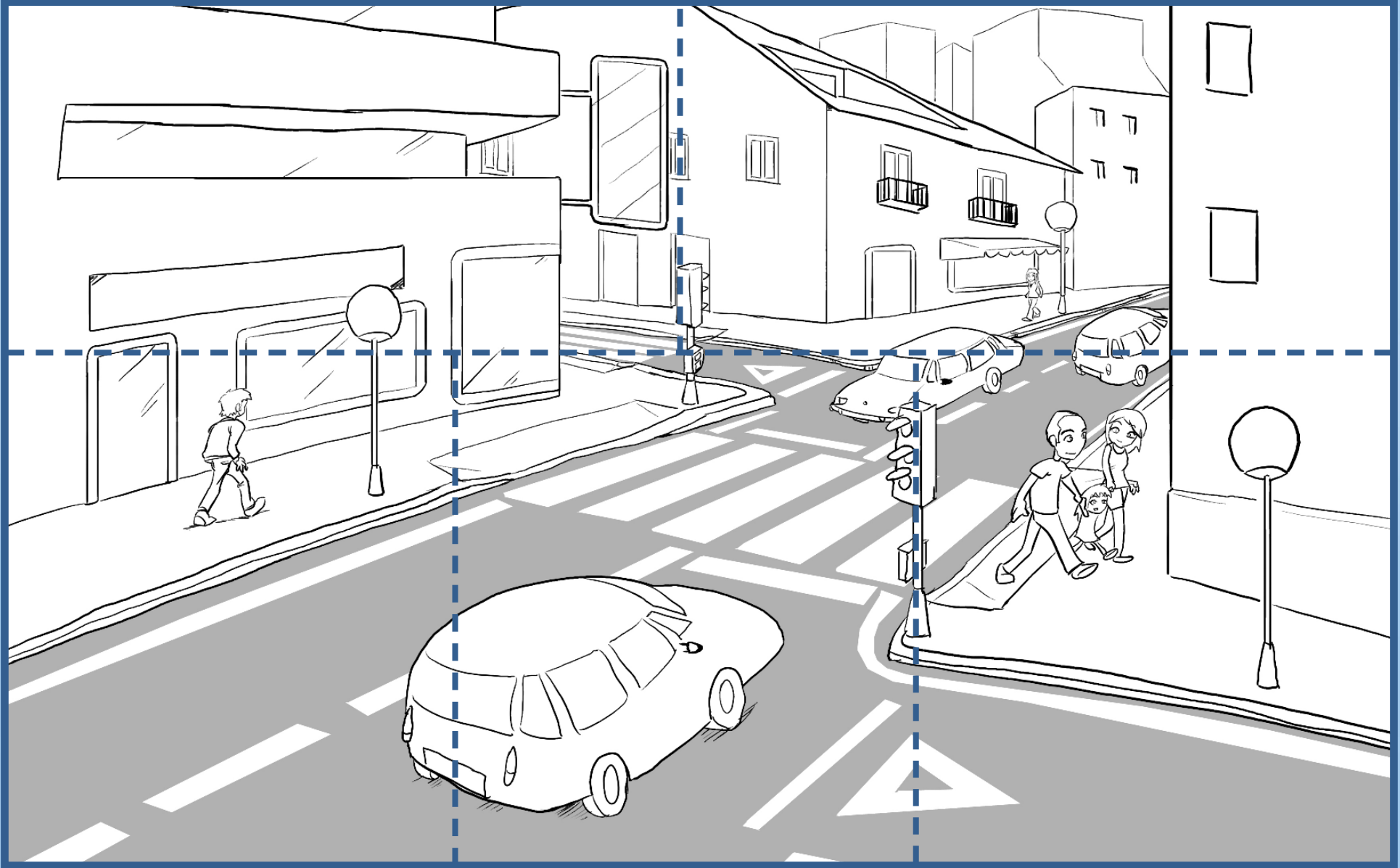

★ Recorta las piezas de la página anterior y monta el puzle en esta página.

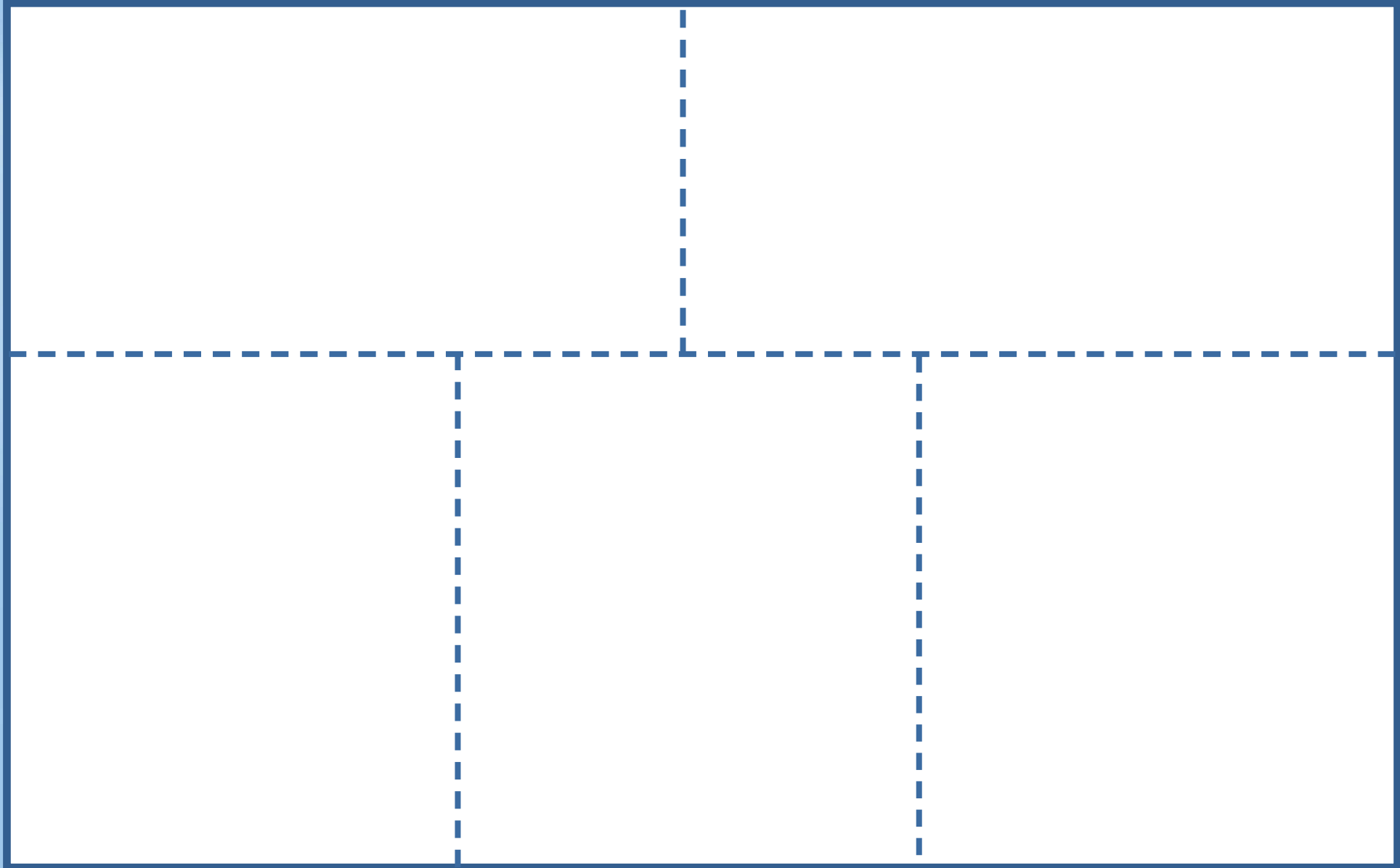

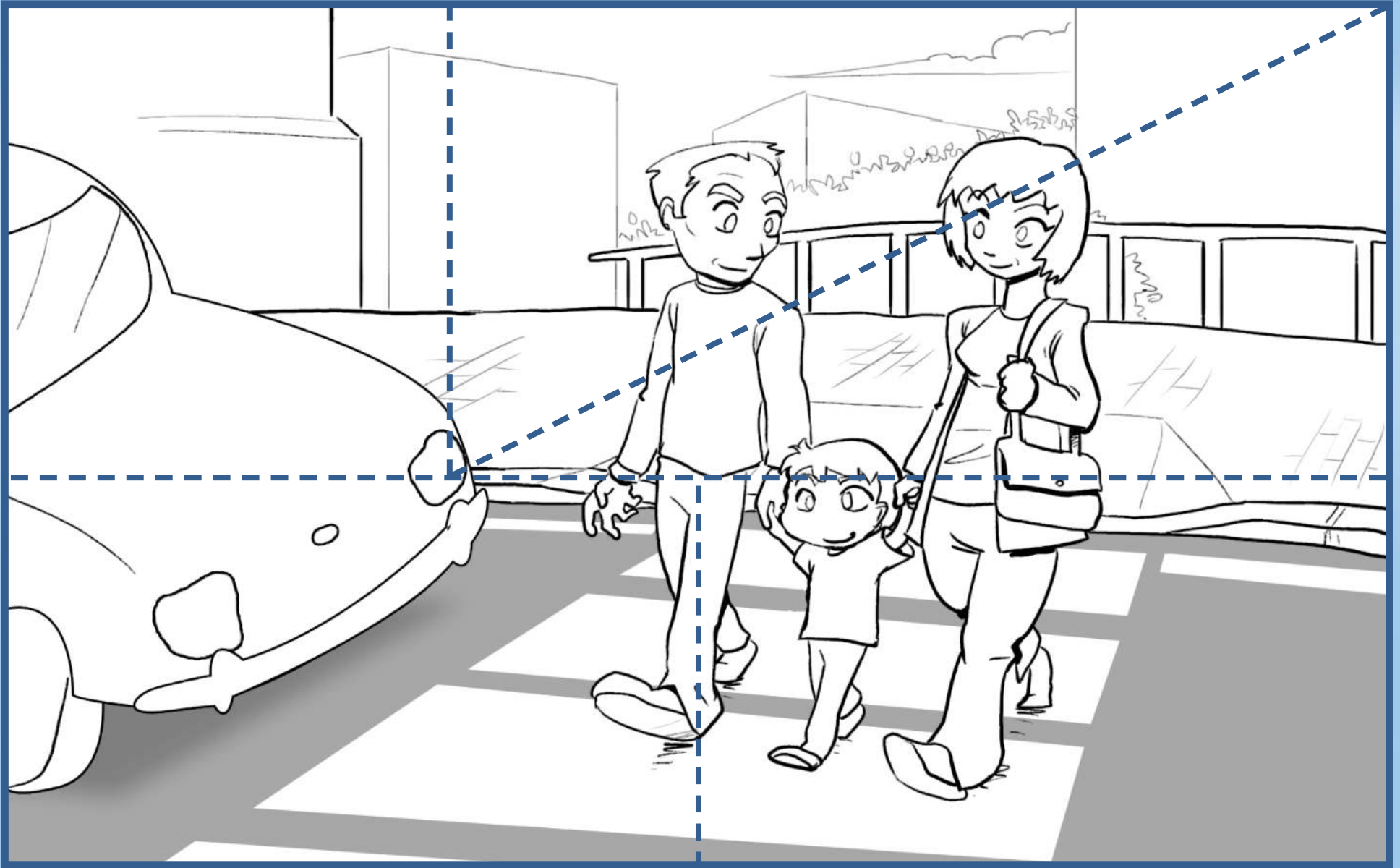



★ Recorta las piezas de la página anterior y monta el puzle en esta página.

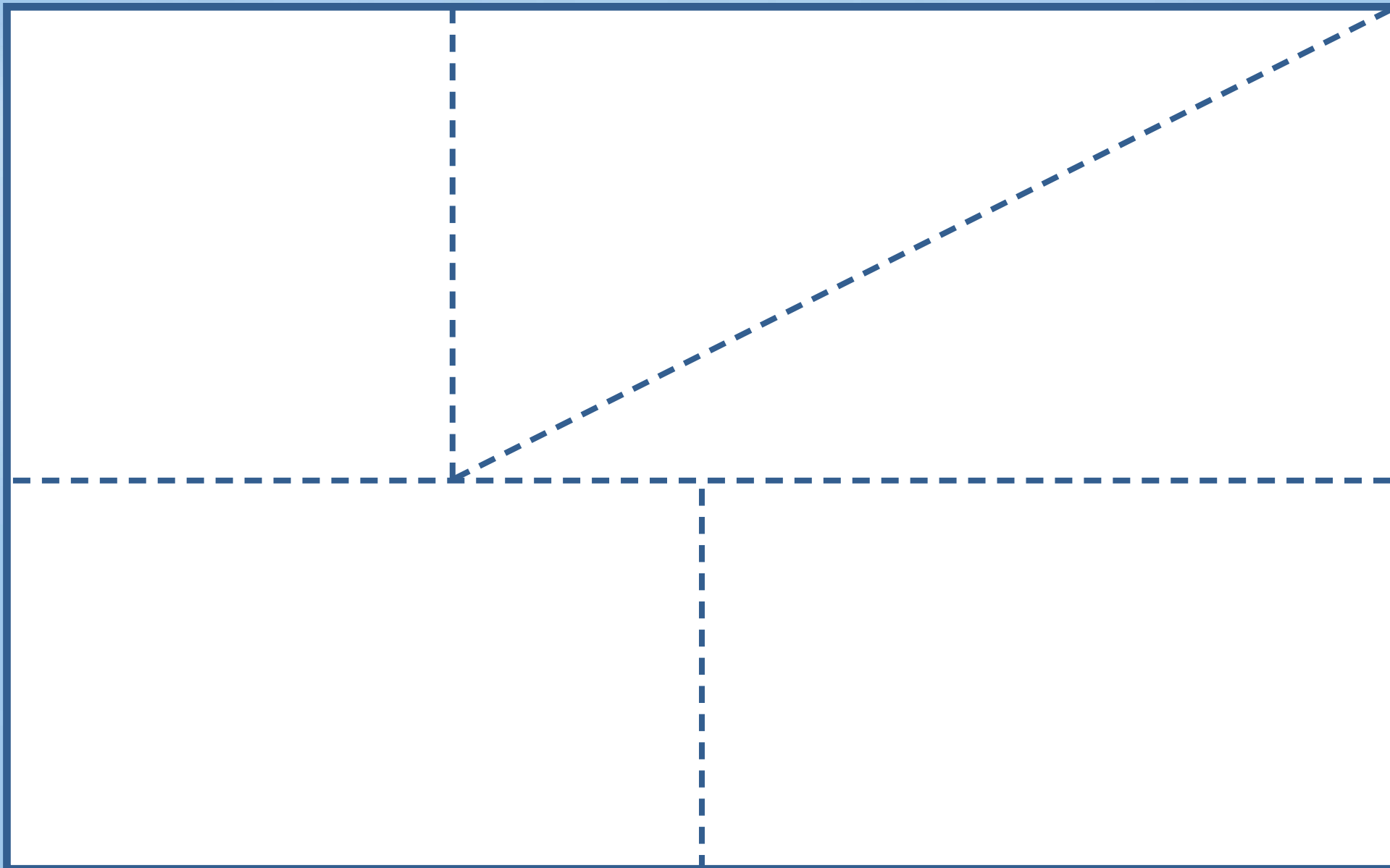

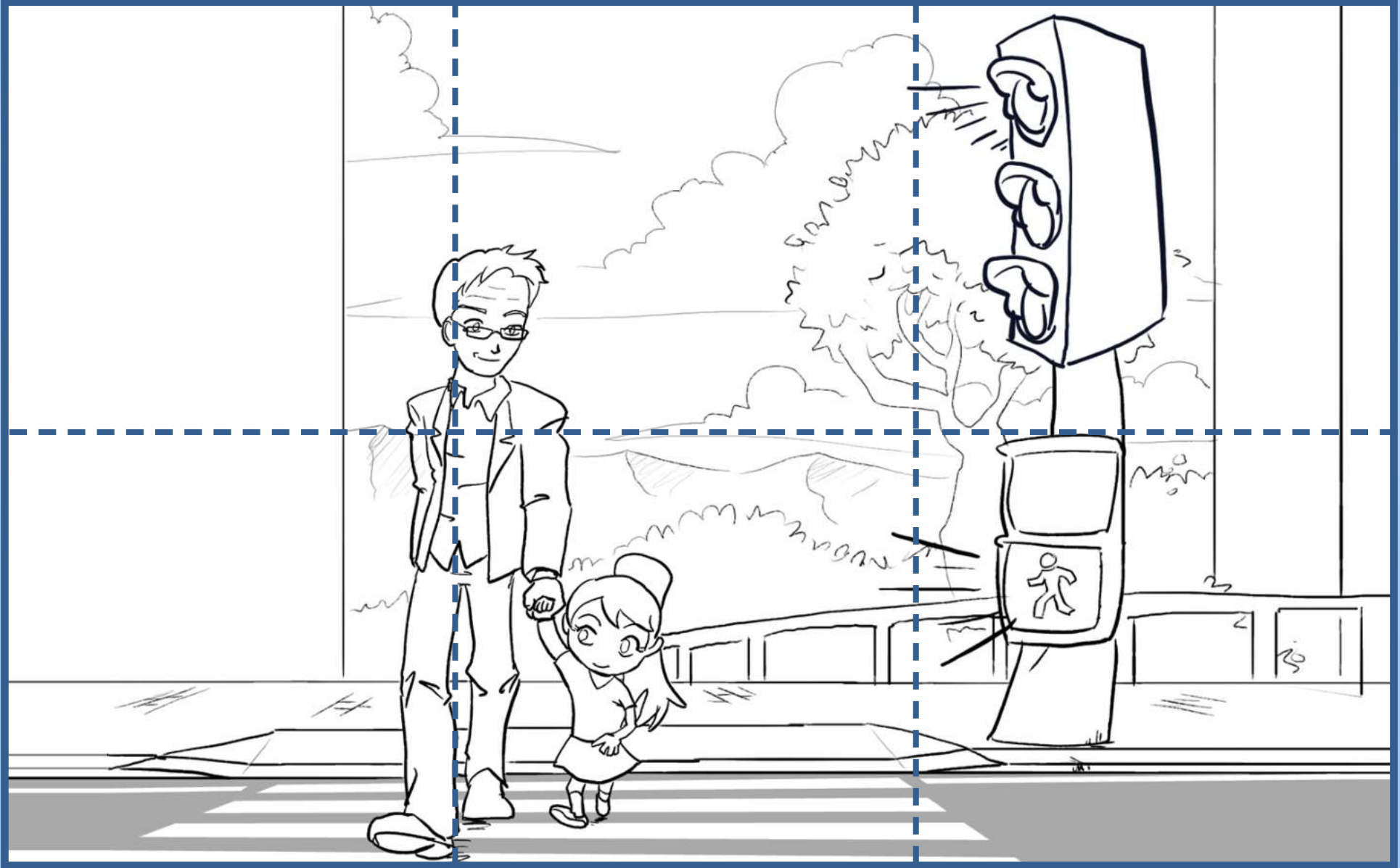

★ Recorta las piezas de la página anterior y monta el puzle en esta página.

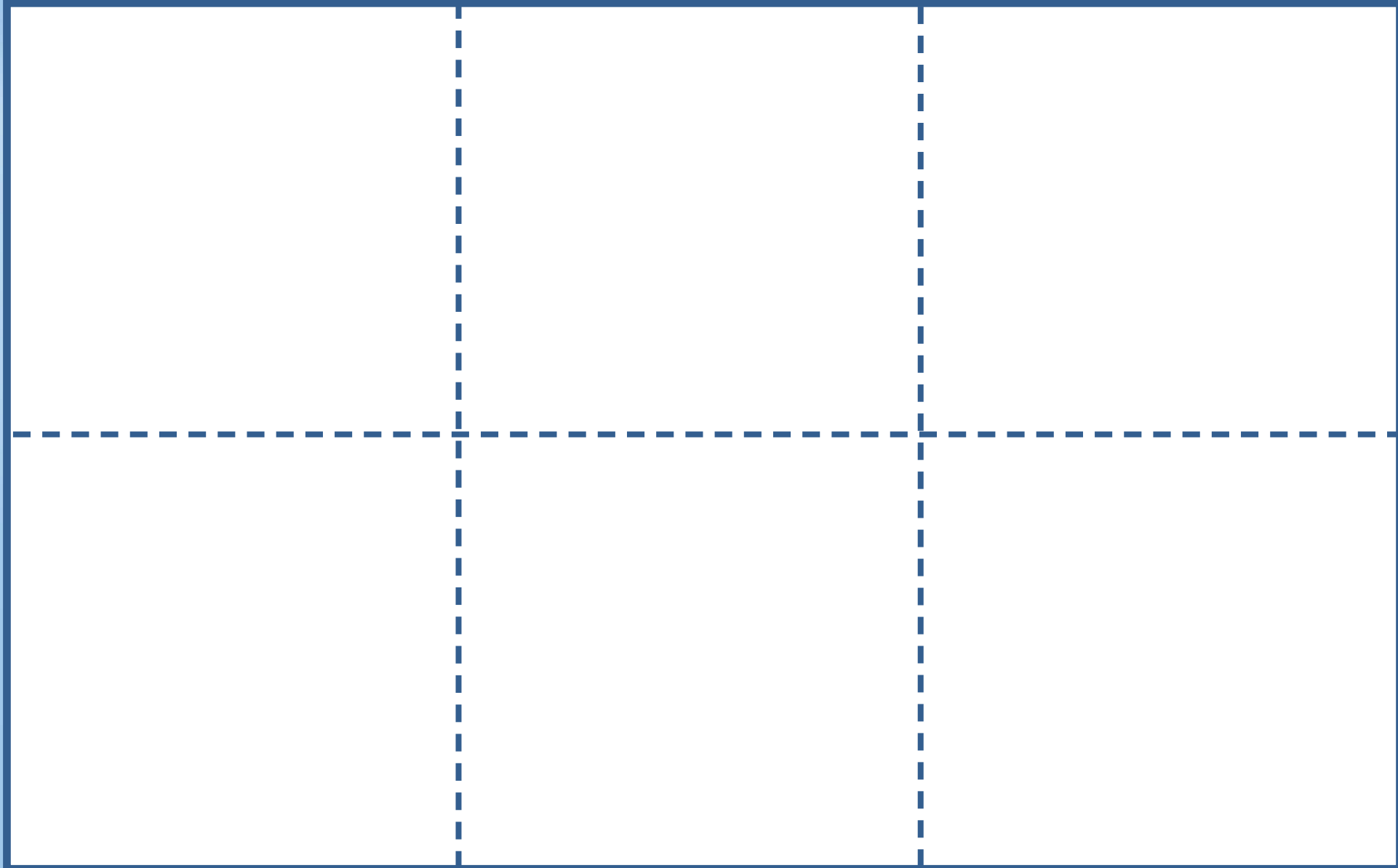

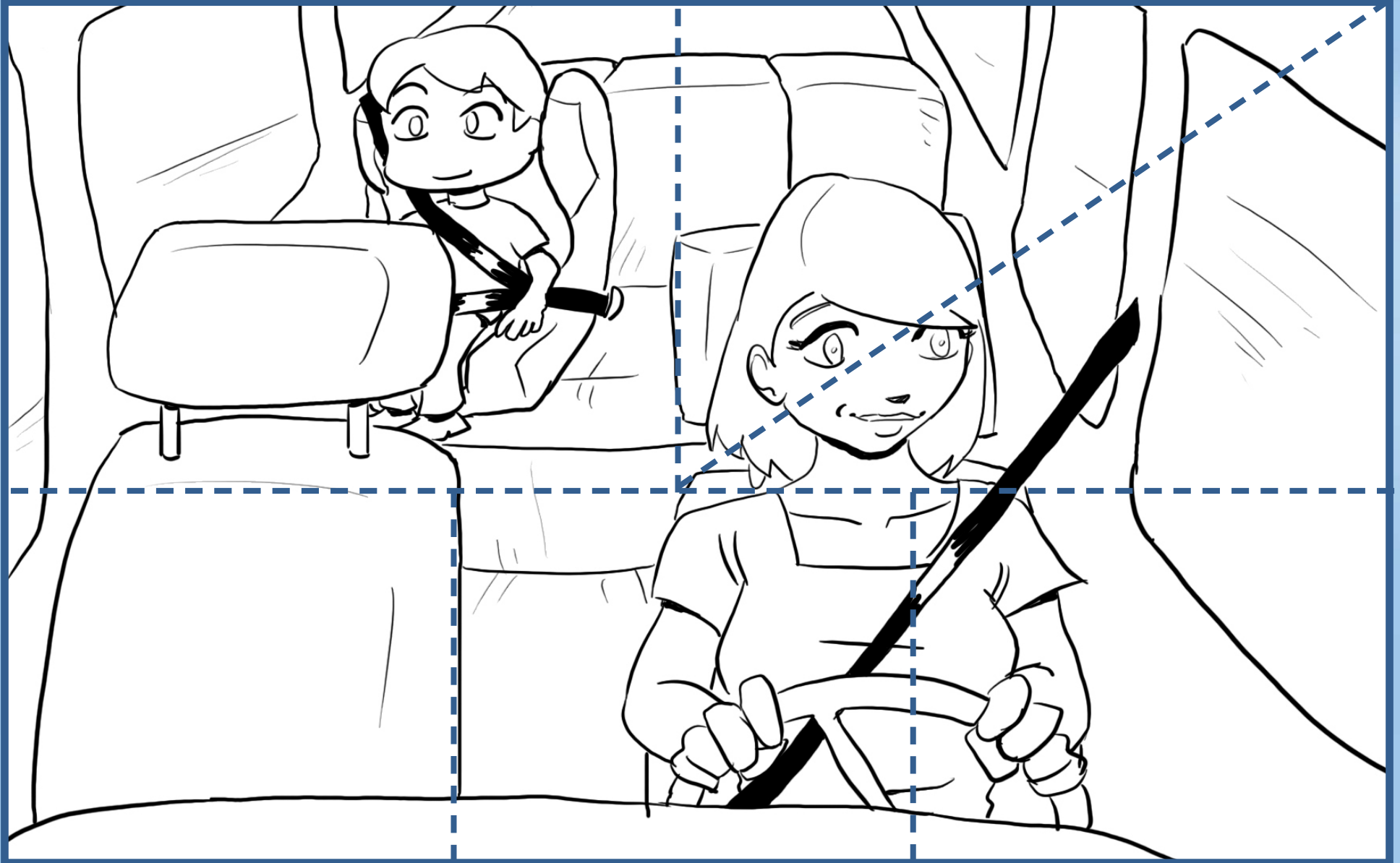

★ Recorta las piezas de la página anterior y monta el puzle en esta página.

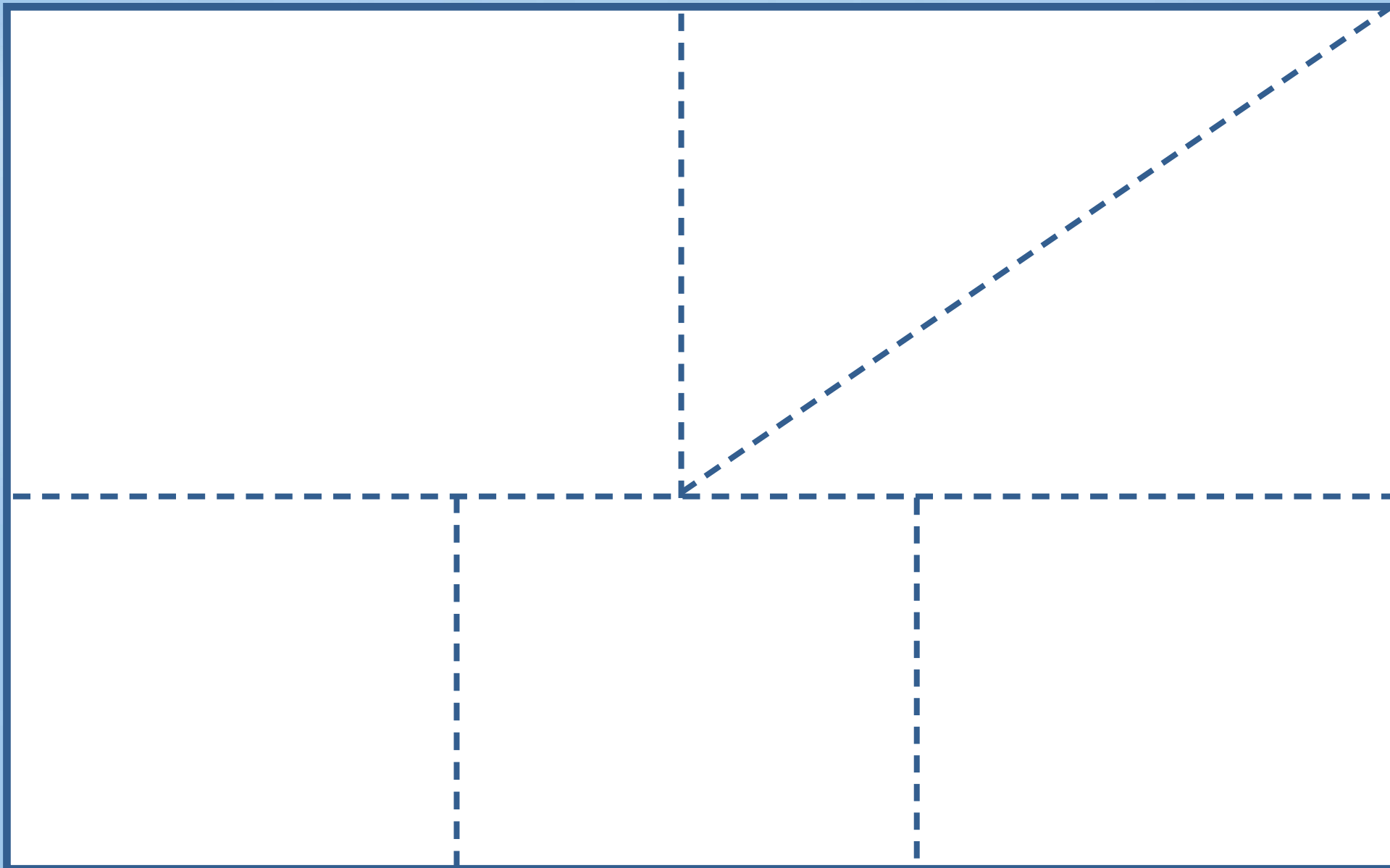

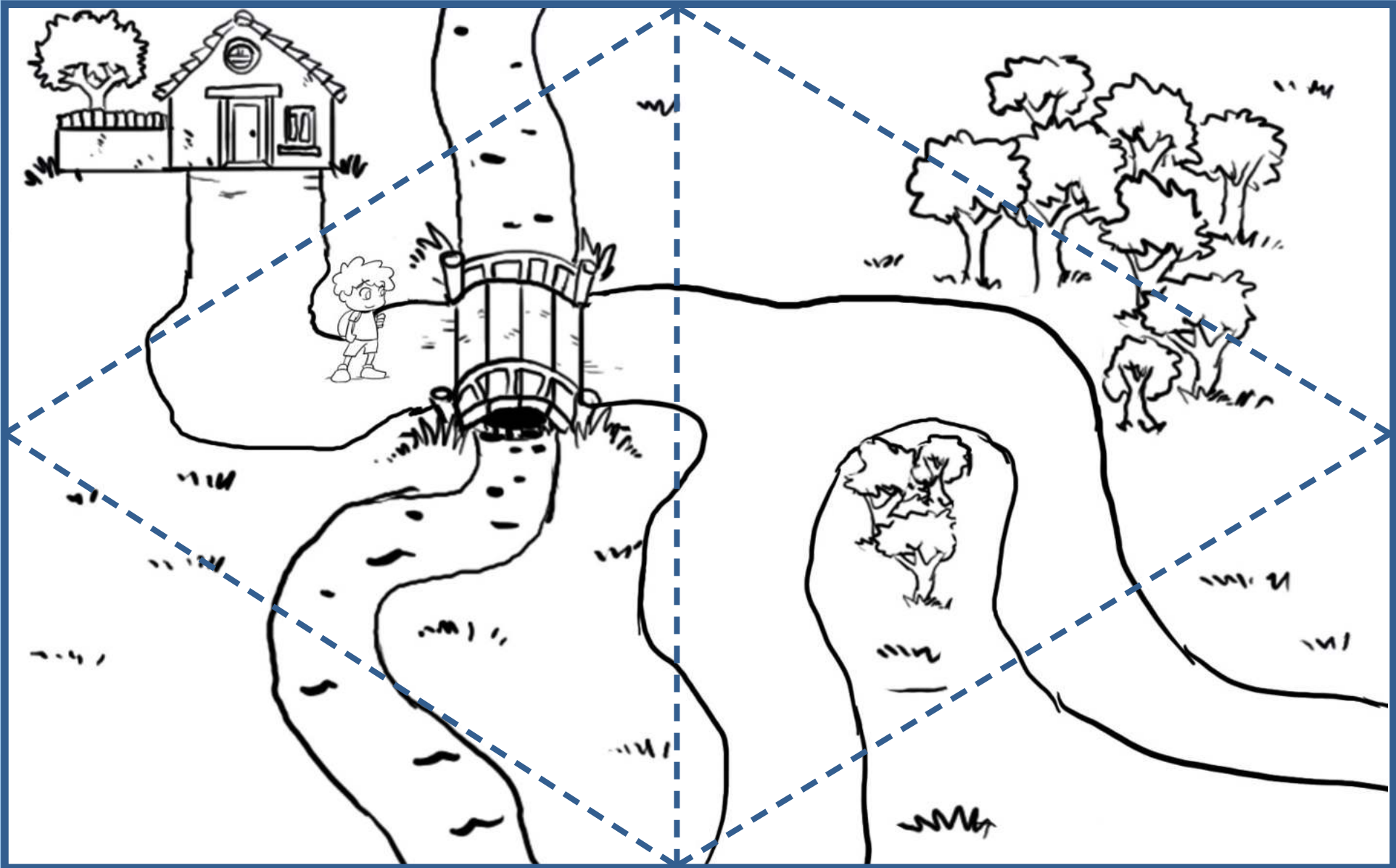

★ Recorta las piezas de la página anterior y monta el puzle en esta página.

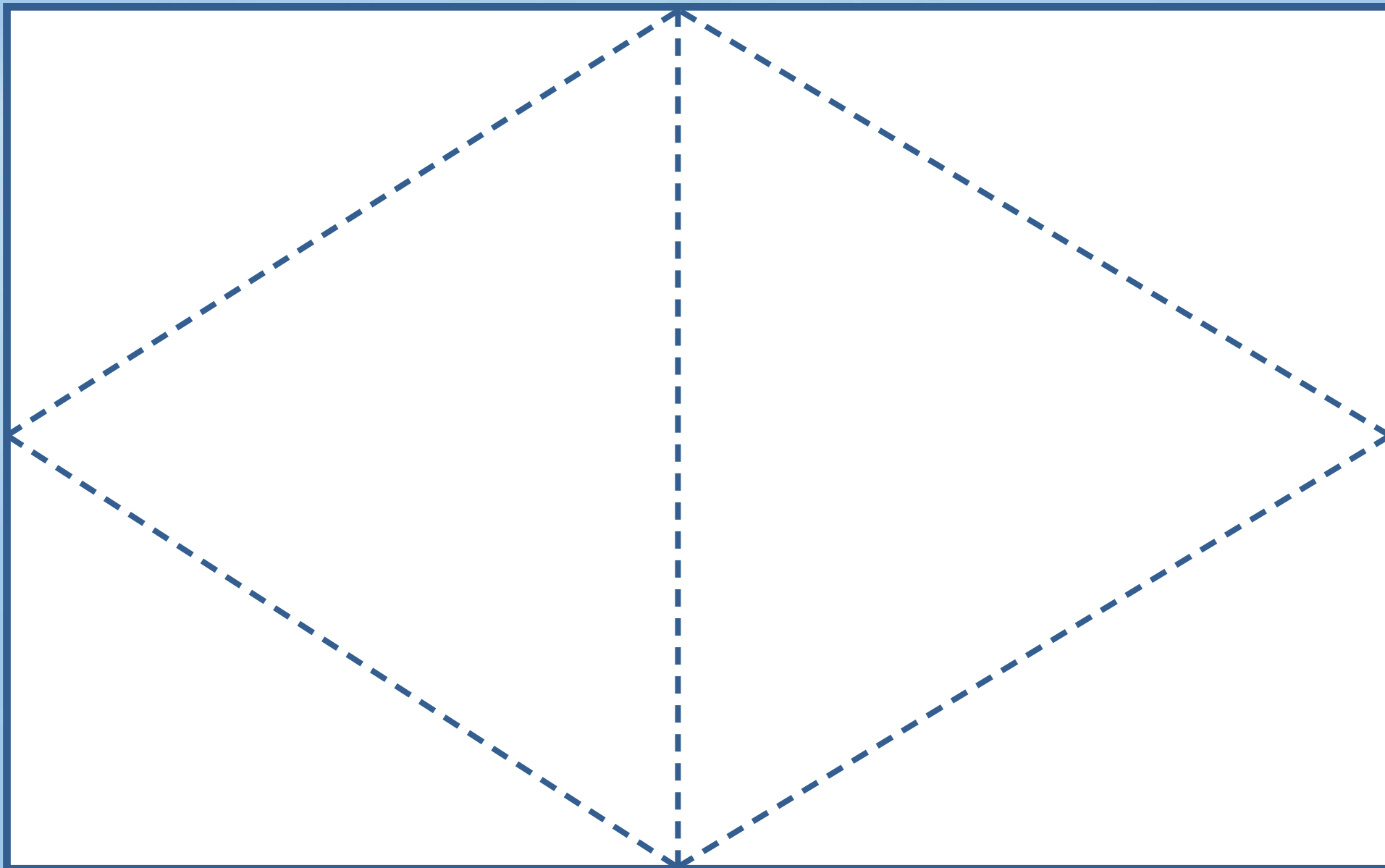



Recorta estas imágenes y ordena la secuencia en la página siguiente.

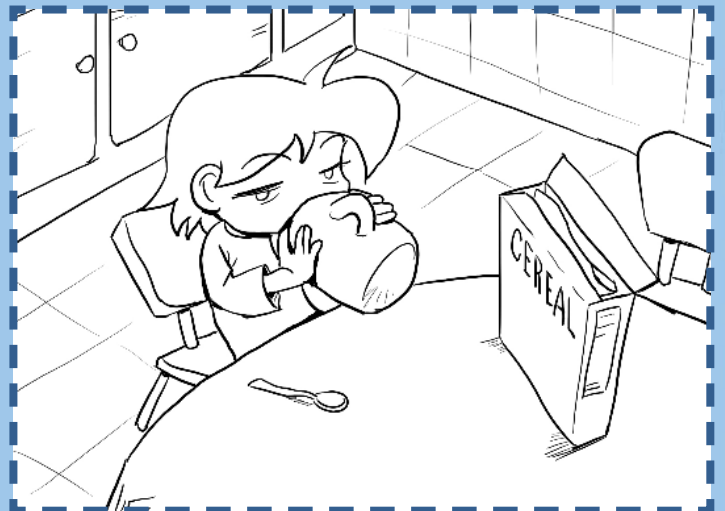
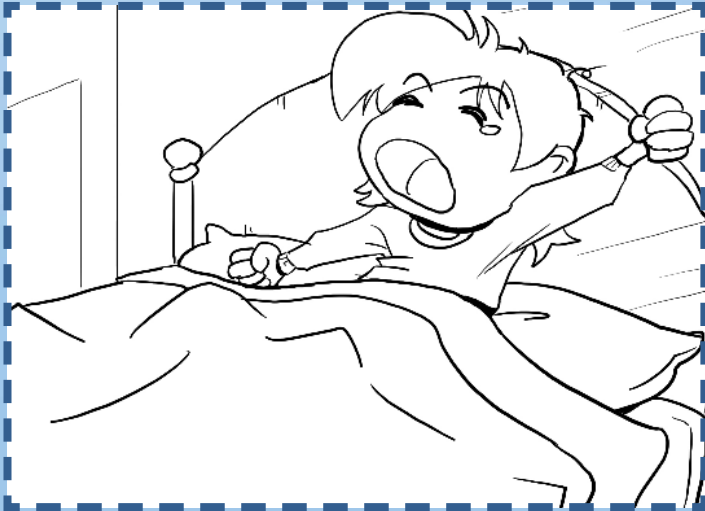
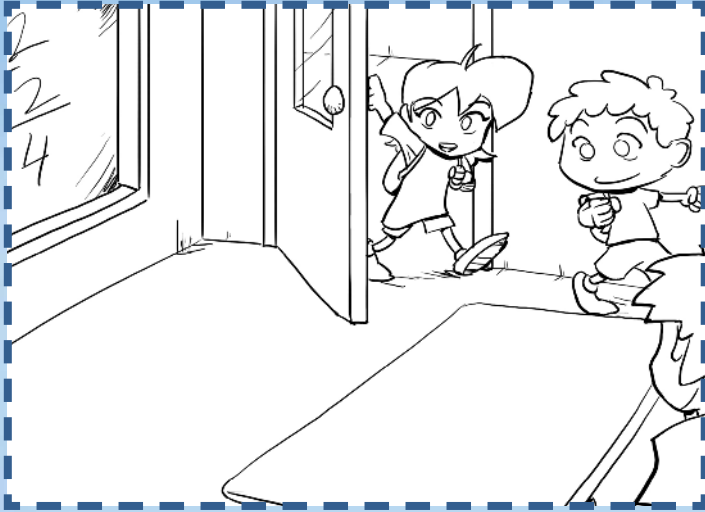



1<sup>a</sup>

2<sup>a</sup>

3<sup>a</sup>

4<sup>a</sup>



Recorta estas imágenes y ordena la secuencia en la página siguiente.

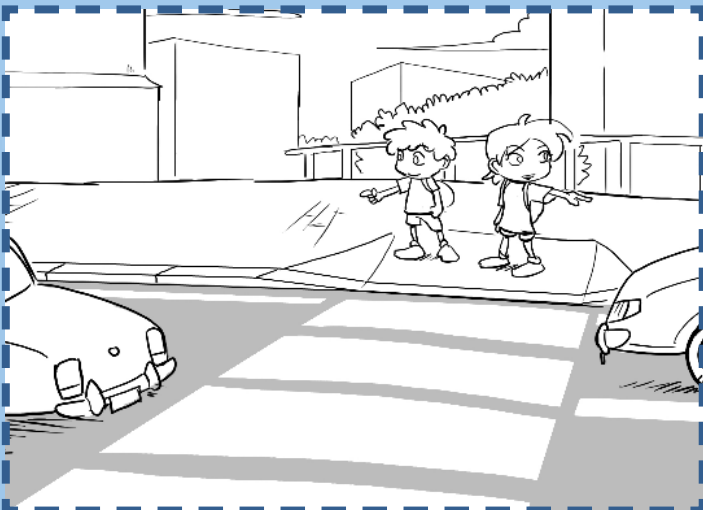
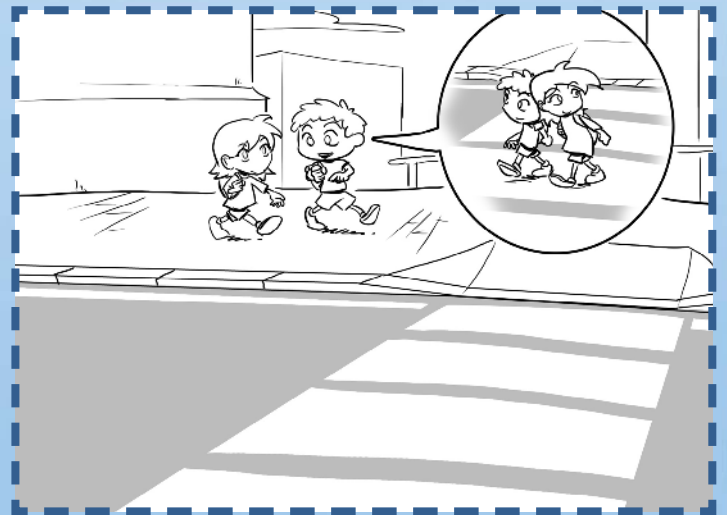
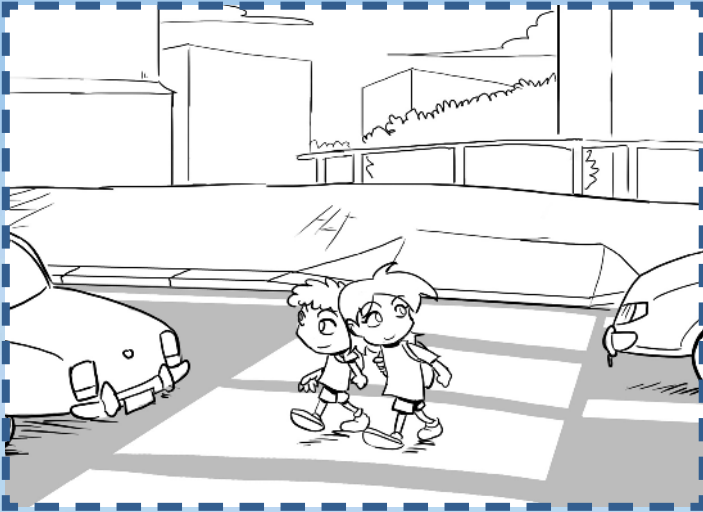

1<sup>a</sup>

2<sup>a</sup>

3<sup>a</sup>



Recorta estas imágenes y ordena la secuencia en la página siguiente.

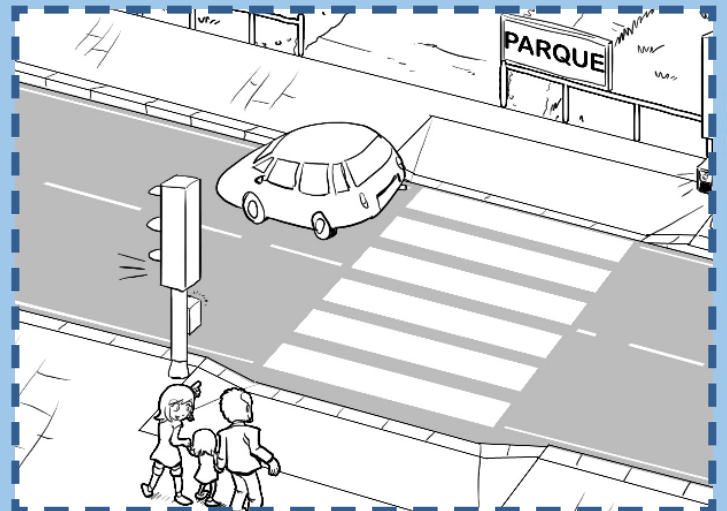
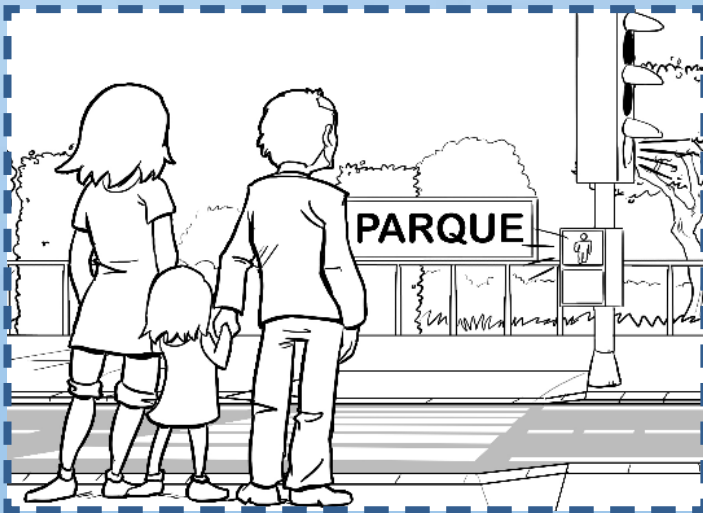
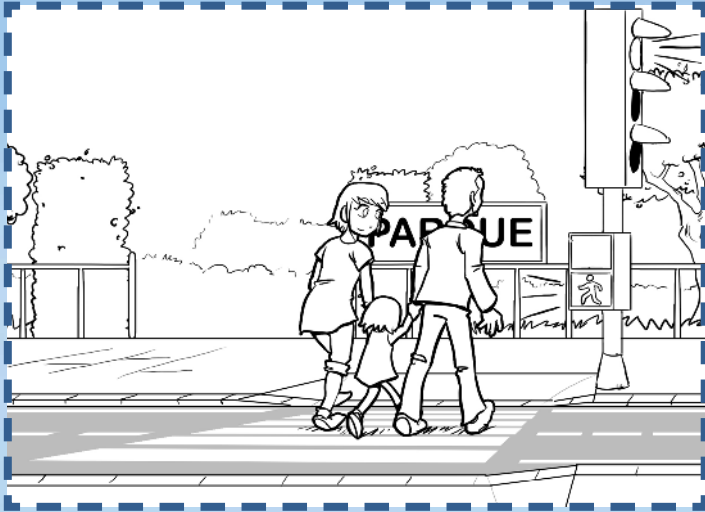

1<sup>a</sup>

2<sup>a</sup>

3<sup>a</sup>

4<sup>a</sup>

★ Recorta y colorea.

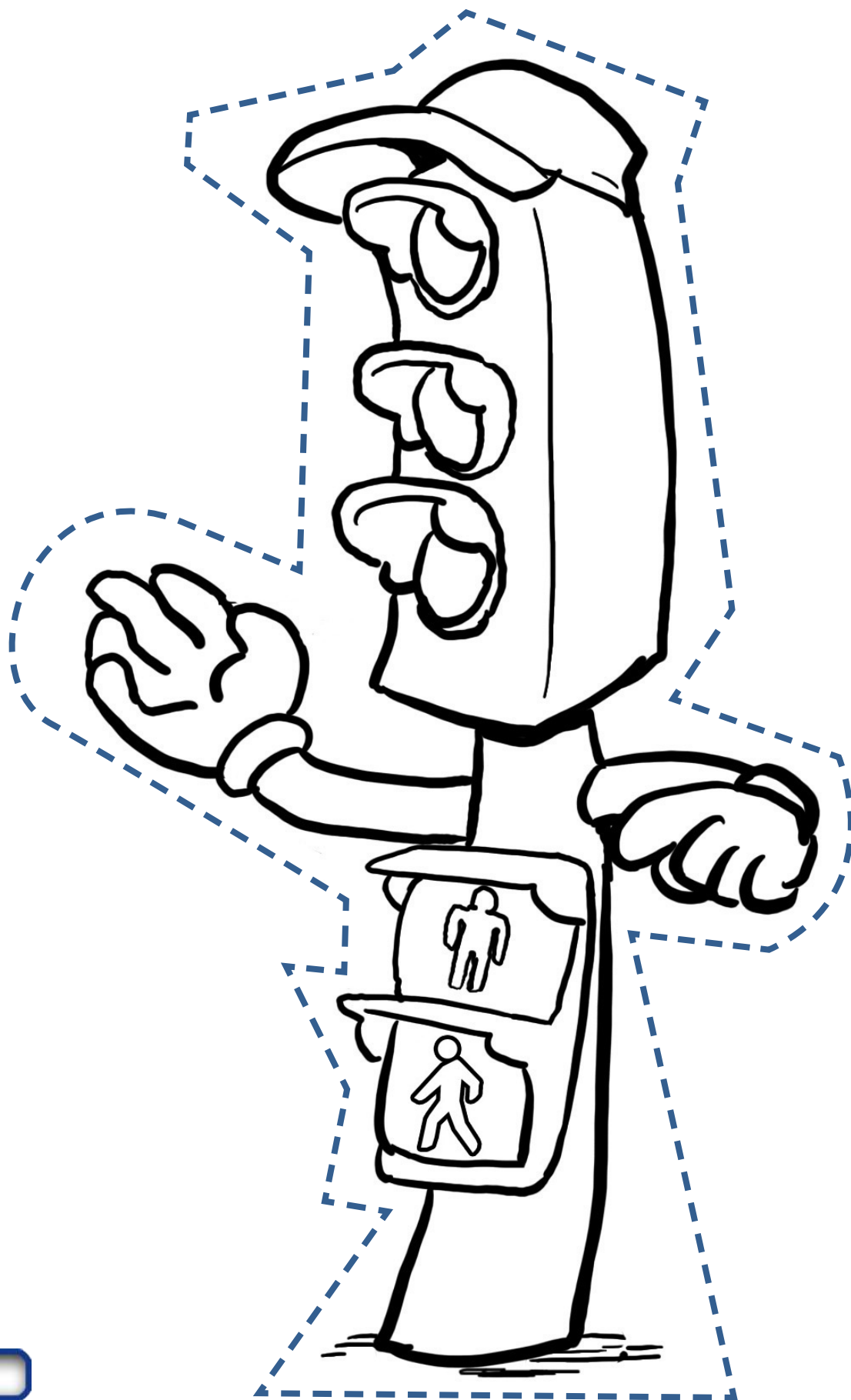

★ Recorta y colorea.

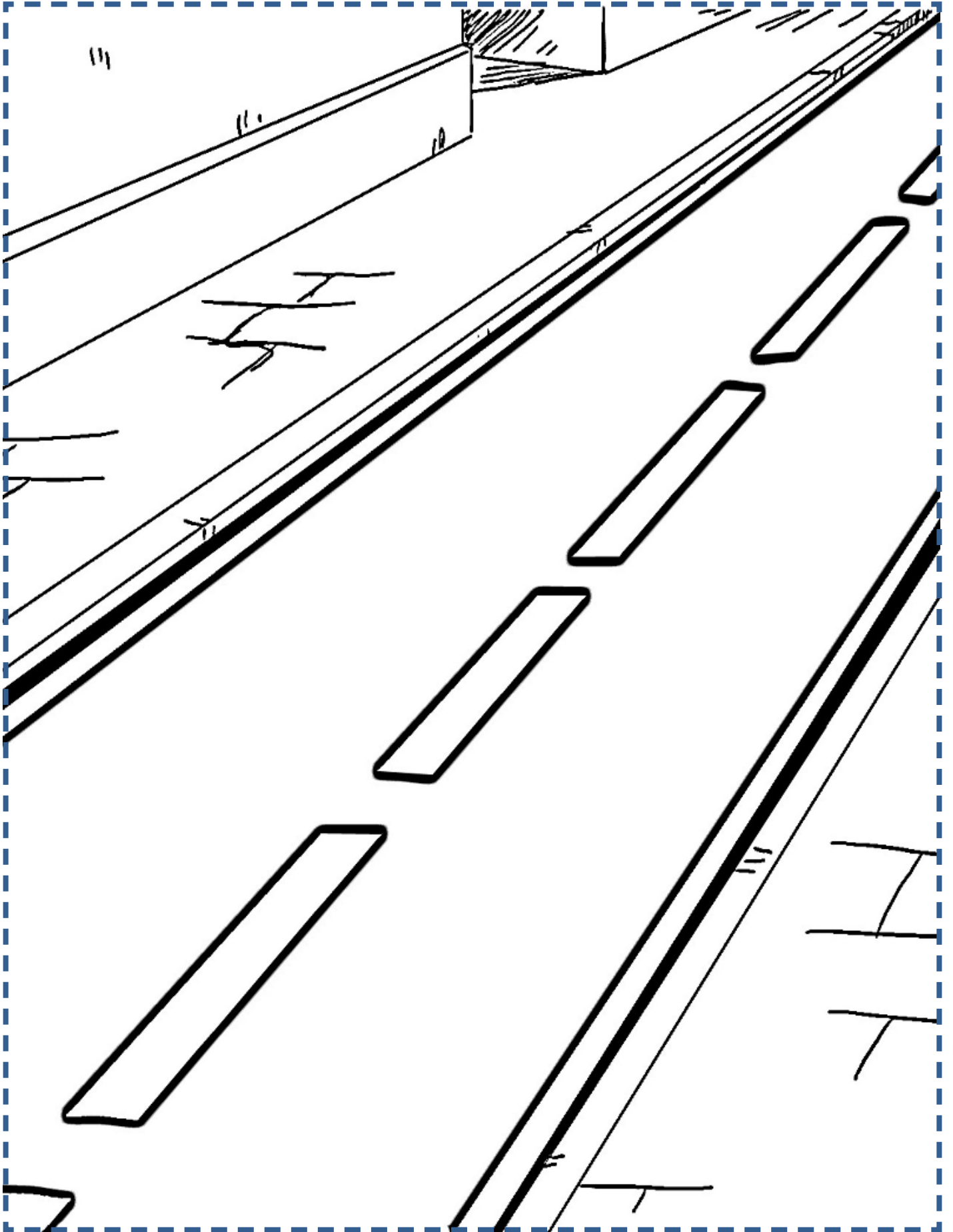

★ Recorta y colorea.

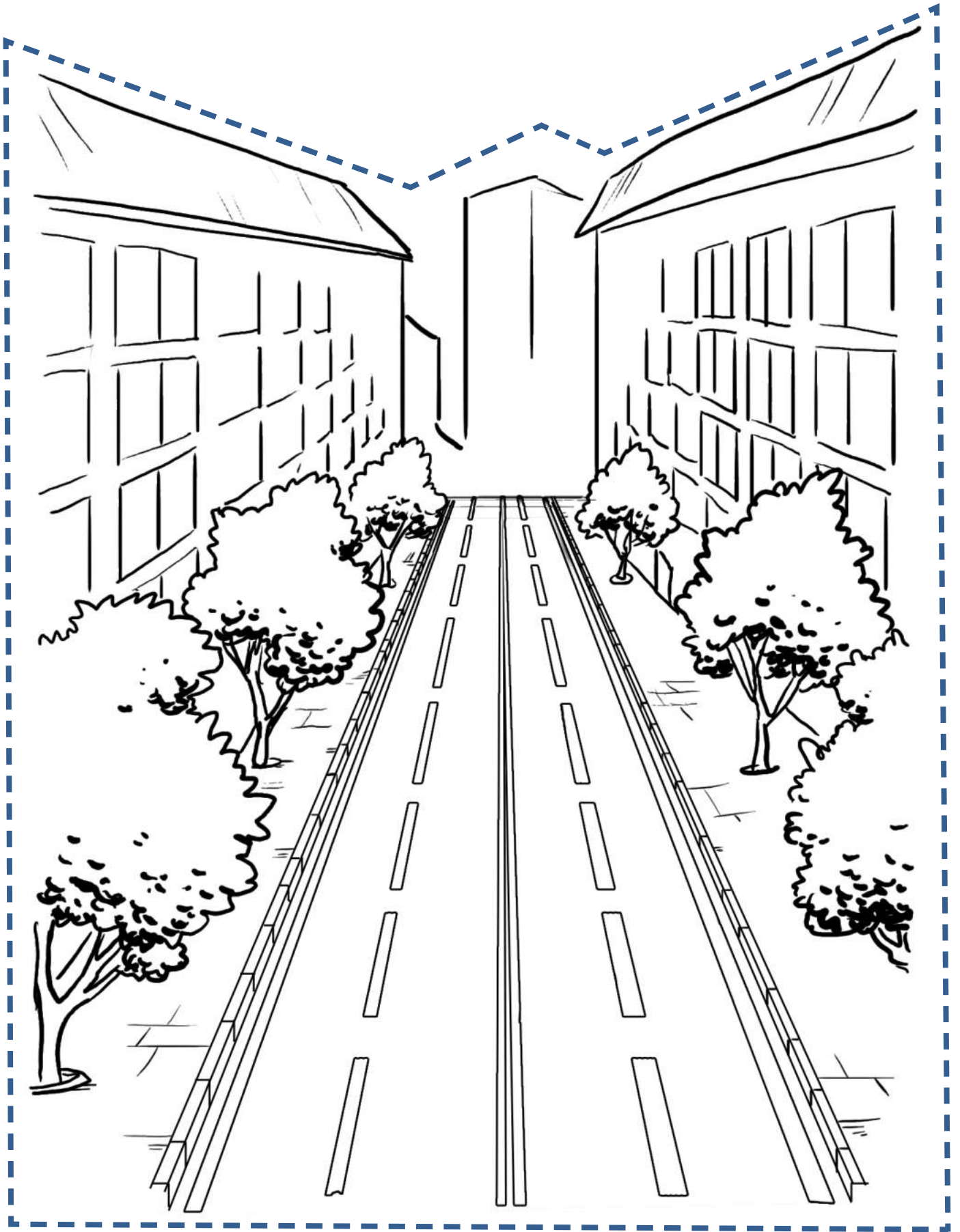



★ Recorta y colorea.

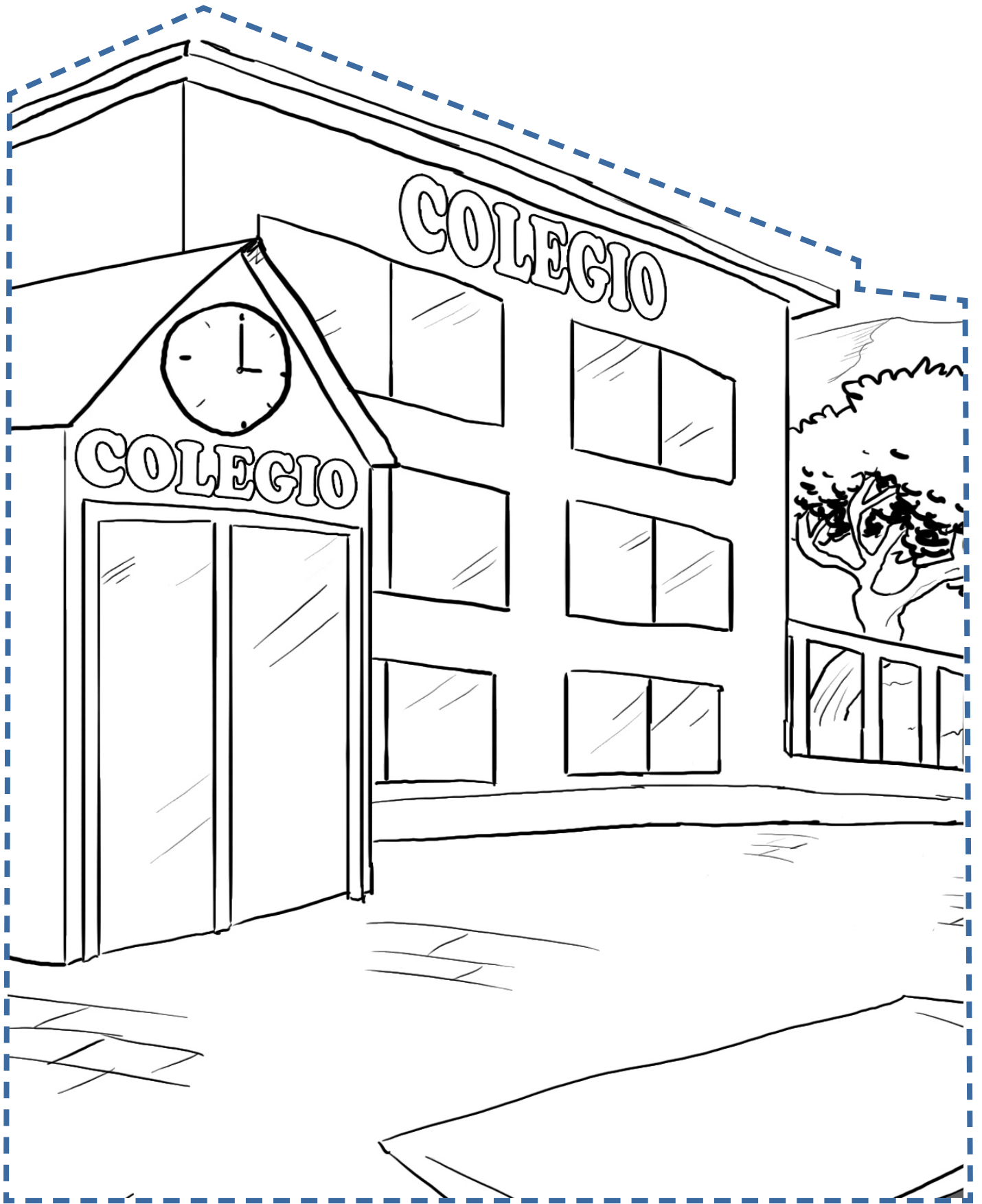

★ Recorta y colorea.

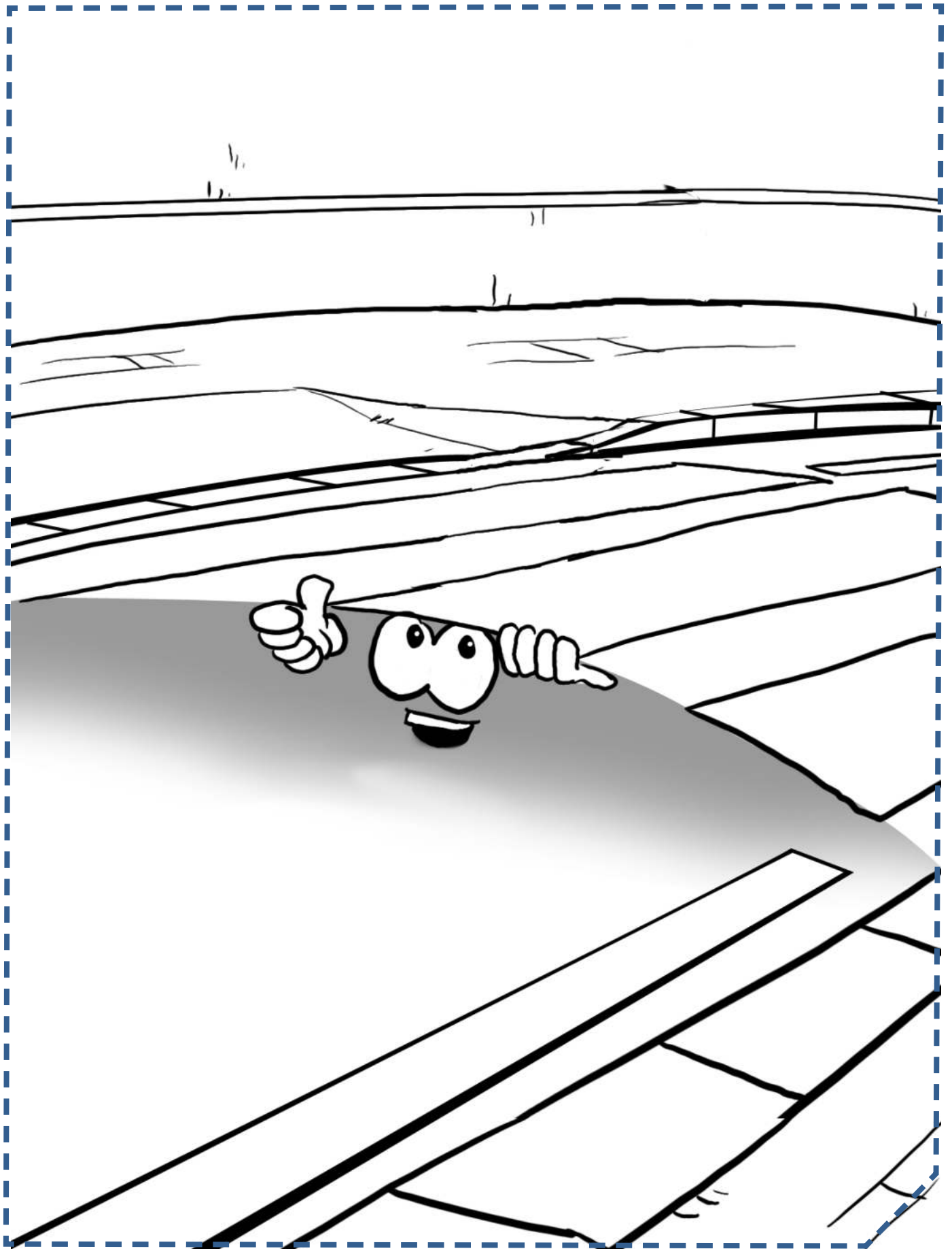

★ Recorta y colorea.

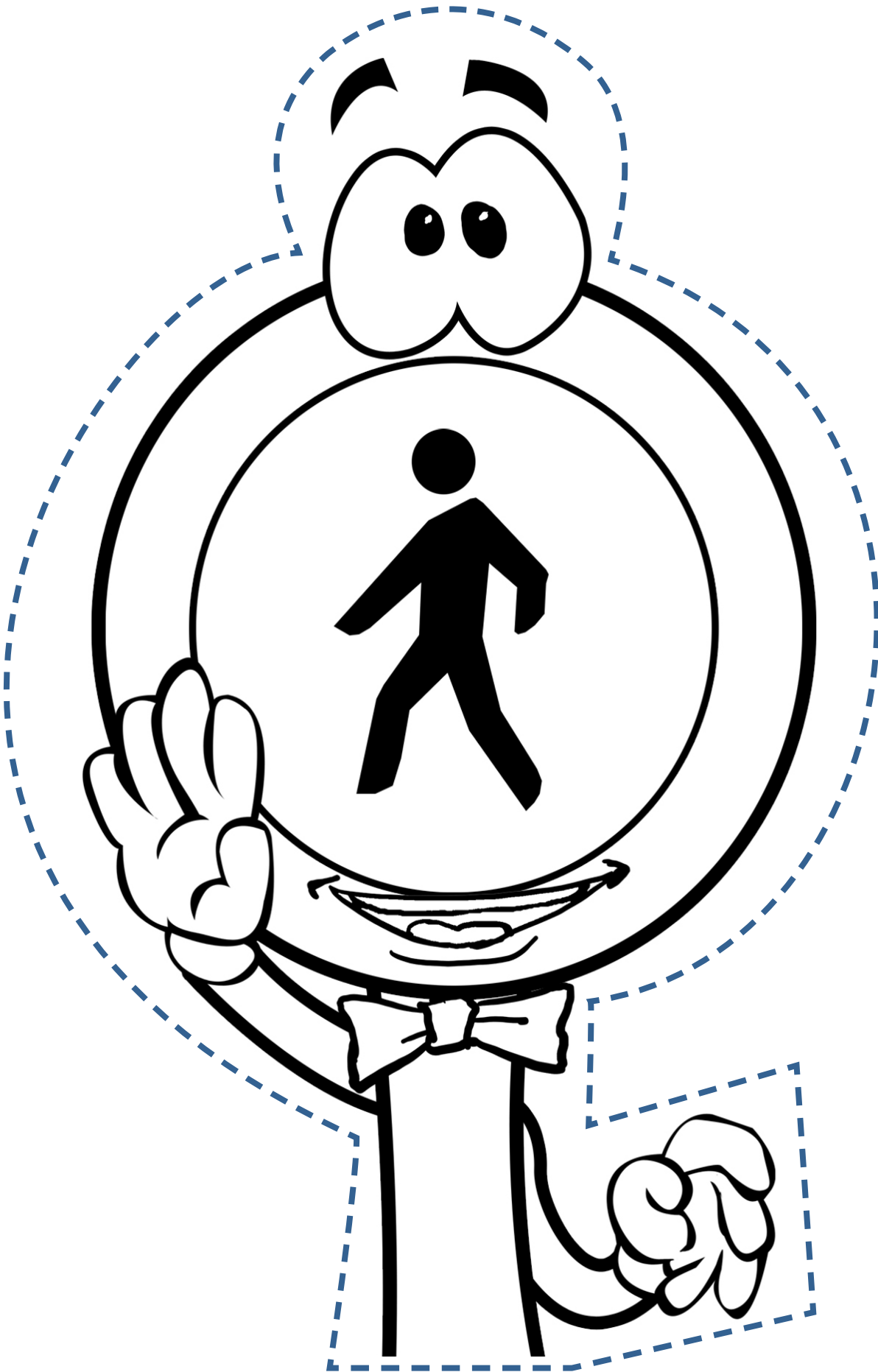

★ Recorta y colorea.

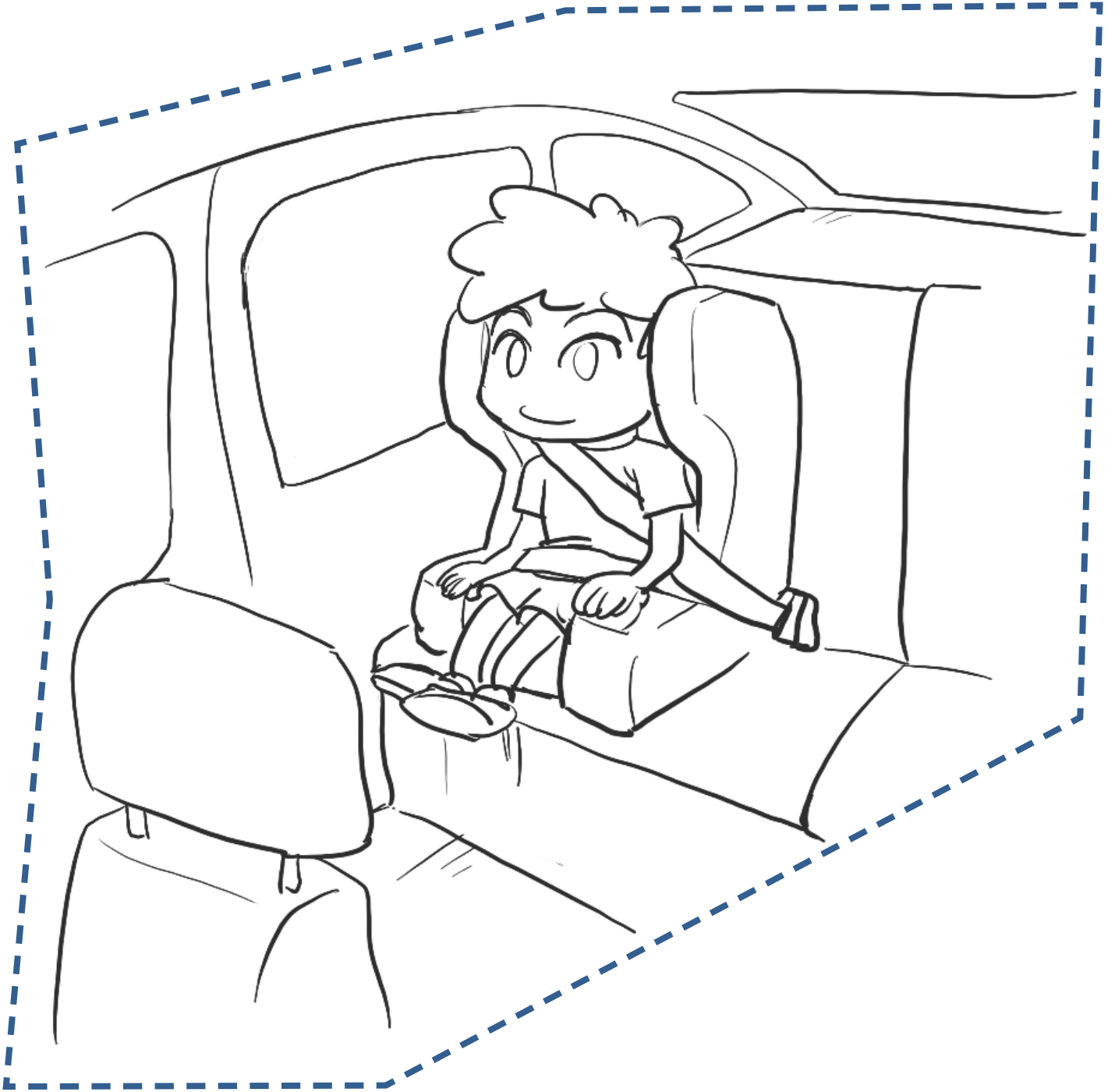

★ Recorta y colorea.

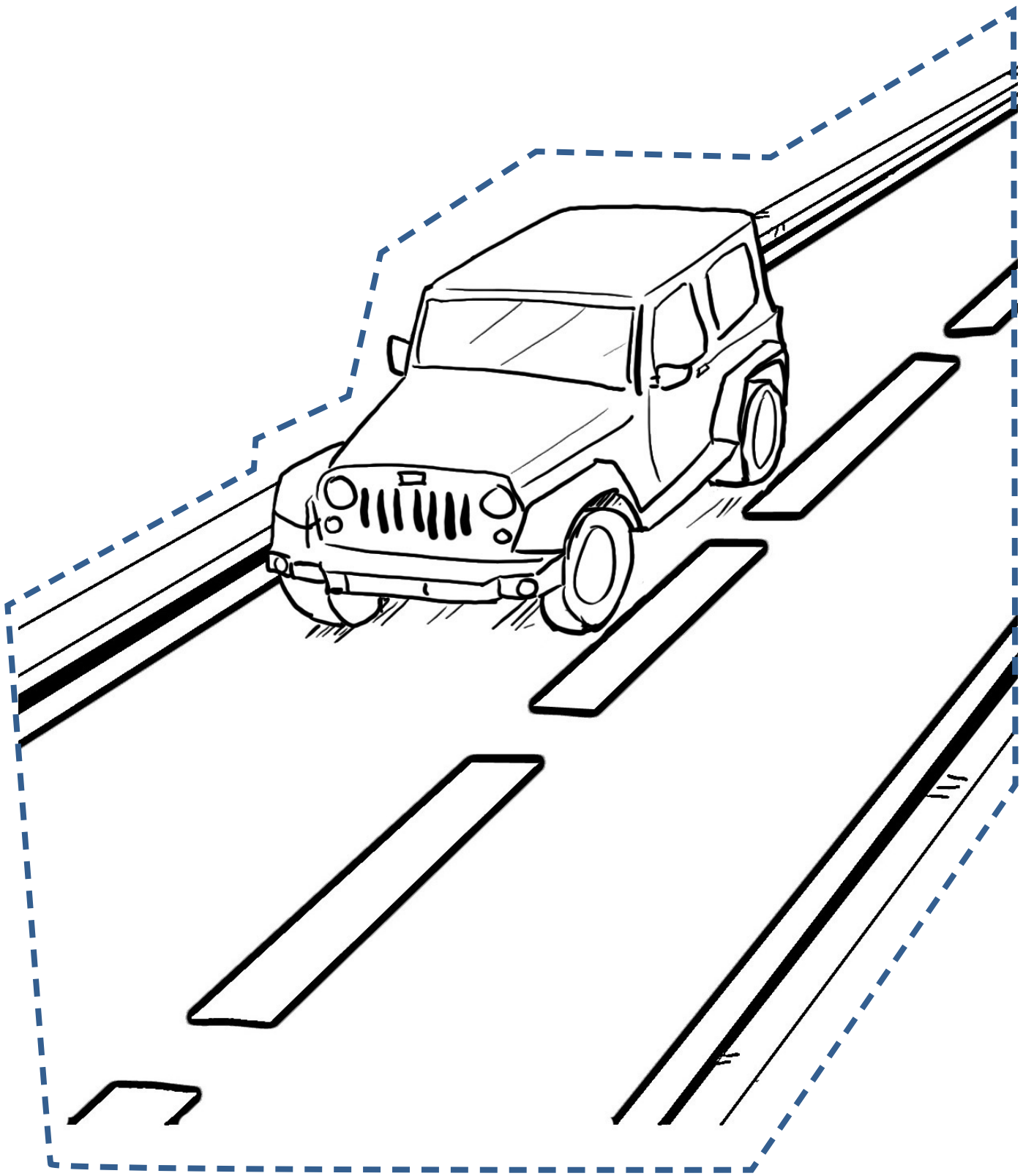



Busca las diferencias que hay en las dos imágenes.

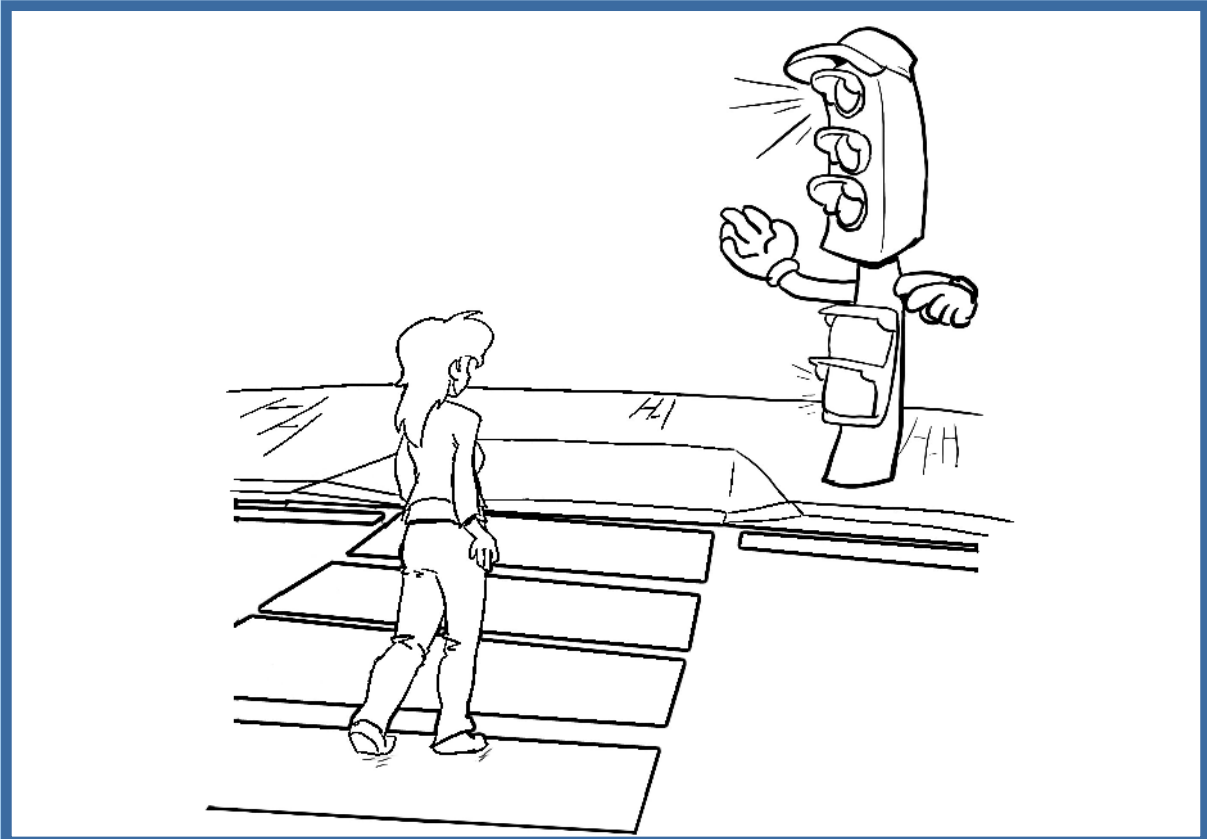
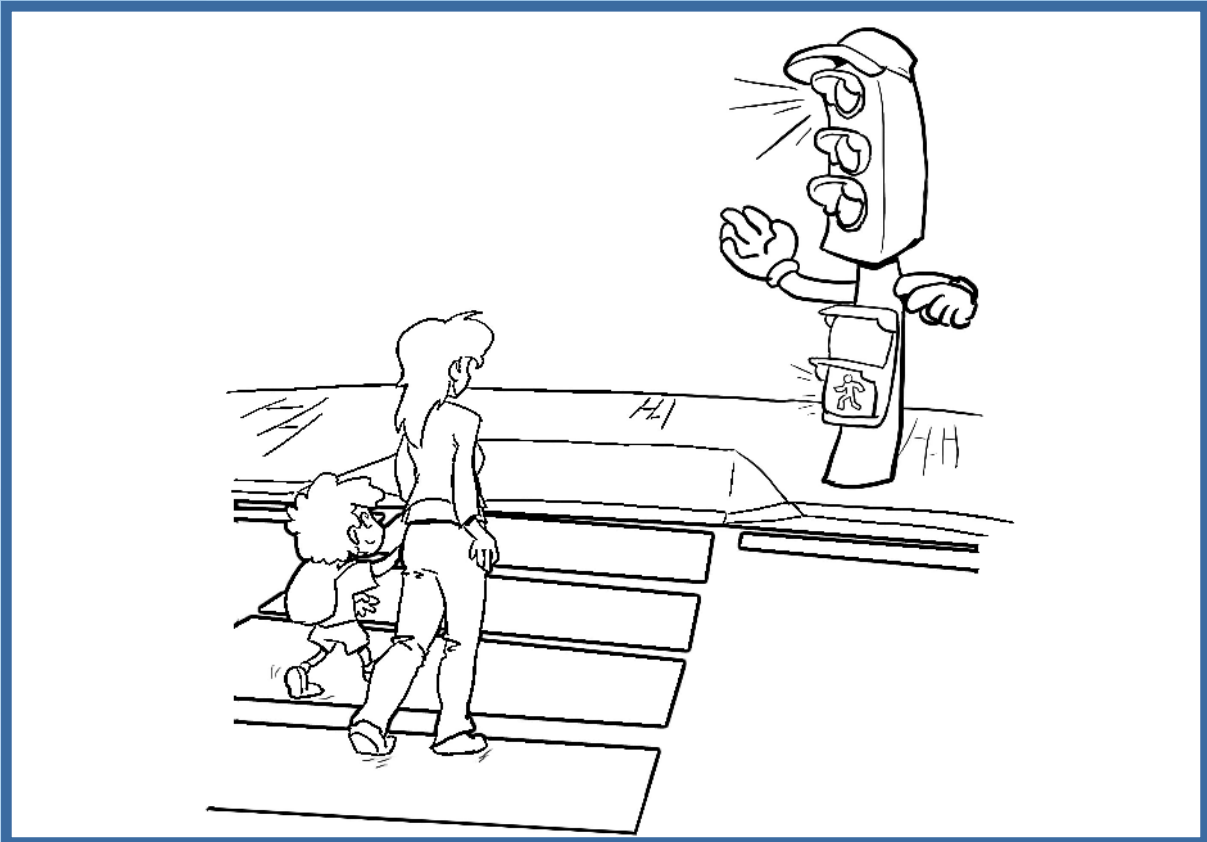



Busca las diferencias que hay en las dos imágenes.

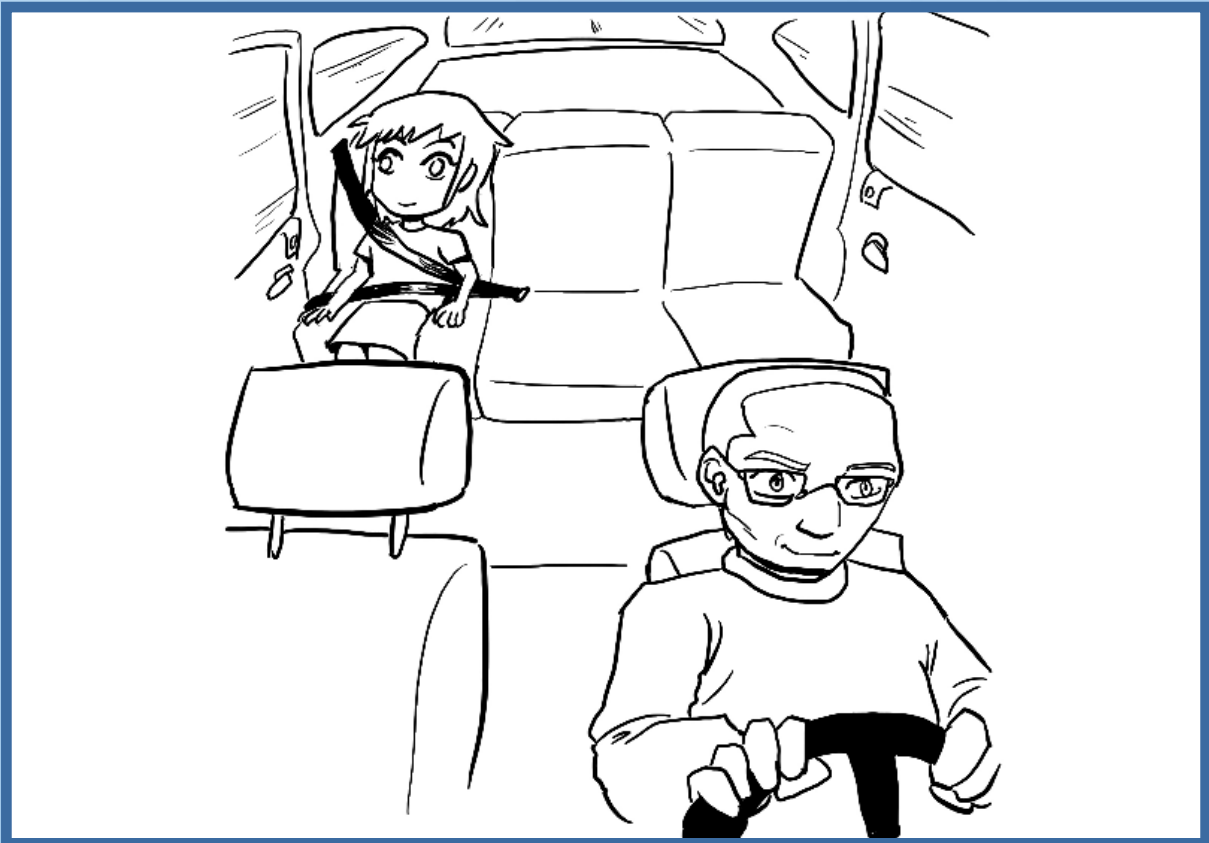
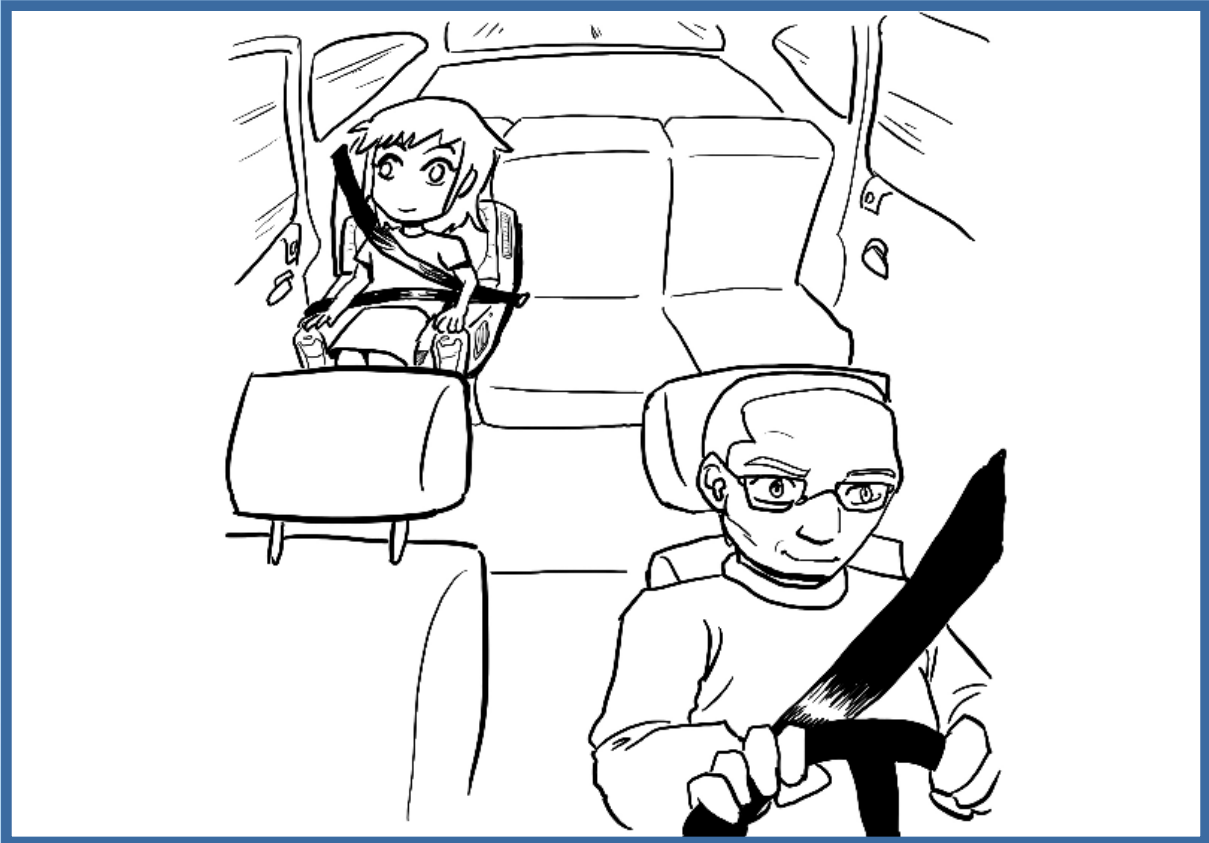



**Busca las diferencias que hay en las dos imágenes.**







**Busca las diferencias que hay en las dos imágenes.**

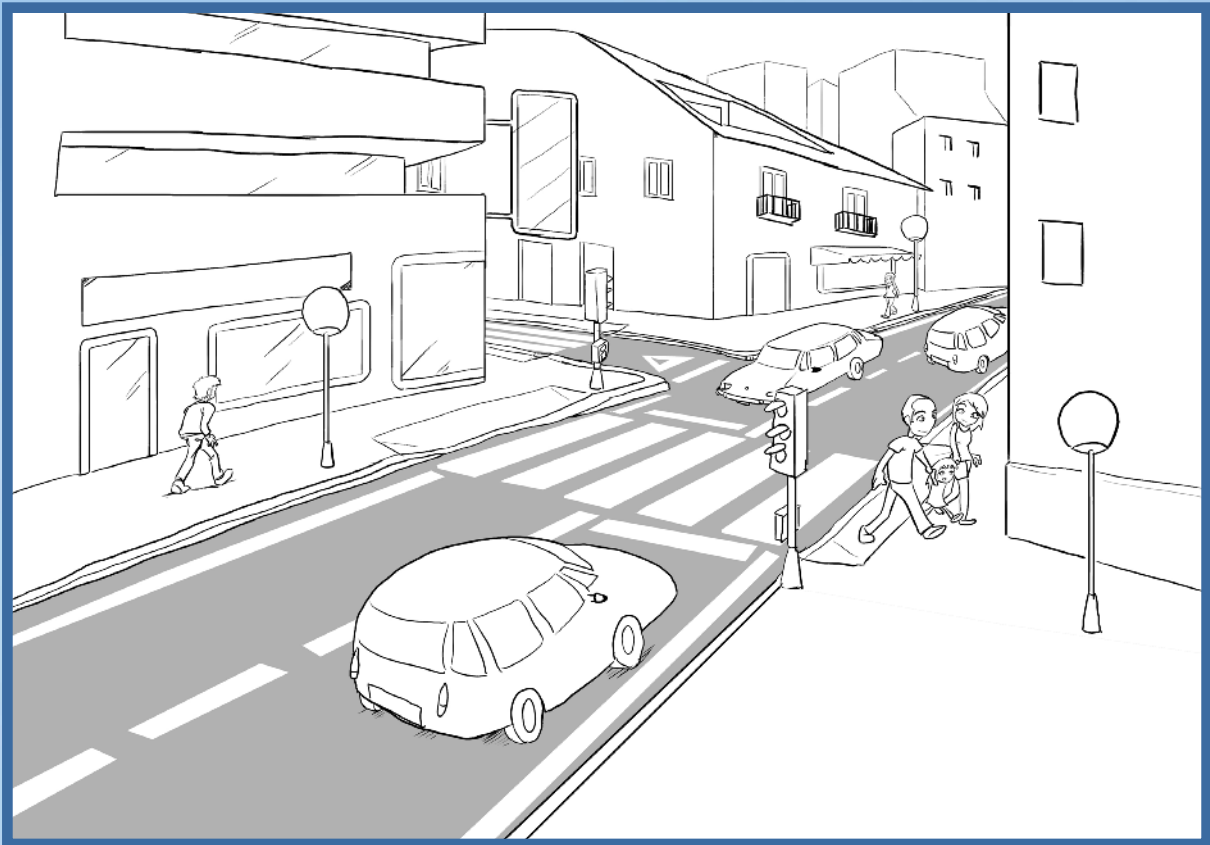



Recorta y reconstruye la señal.





Recorta y reconstruye la señal.





Recorta y reconstruye la señal.





Recorta y reconstruye la señal.

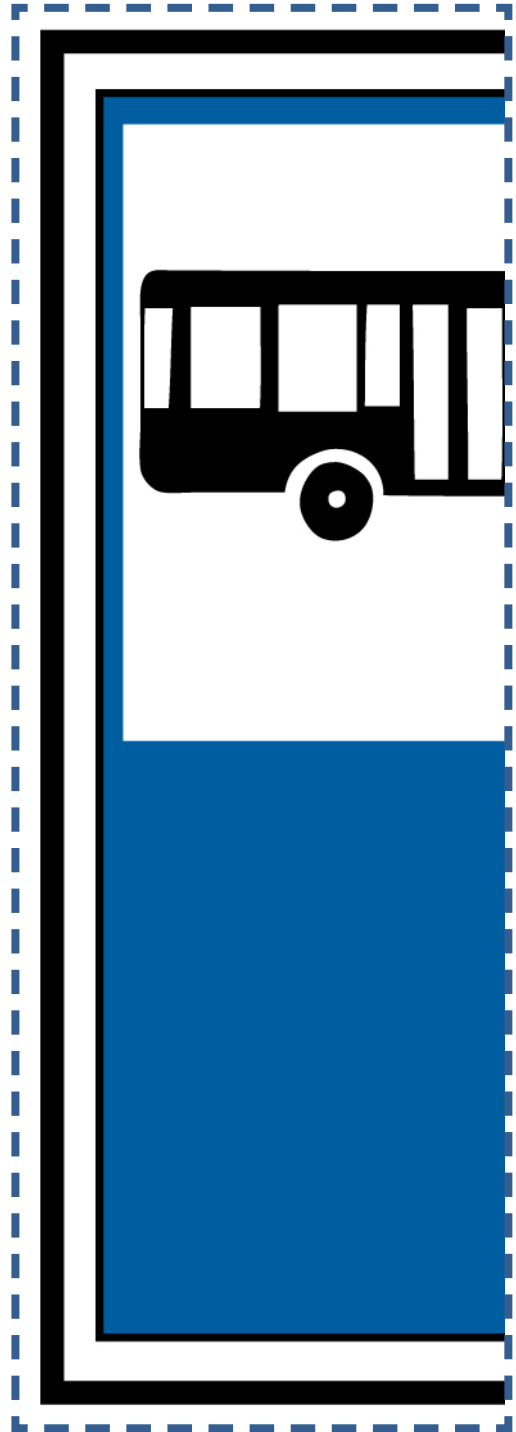
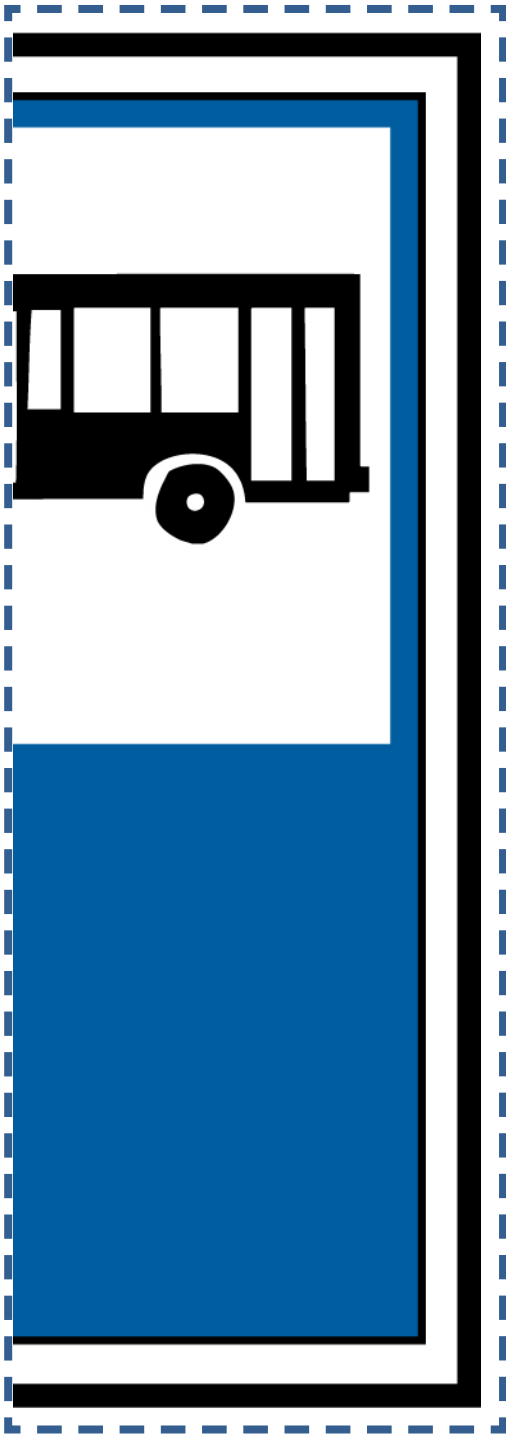



Recorta y reconstruye la señal.

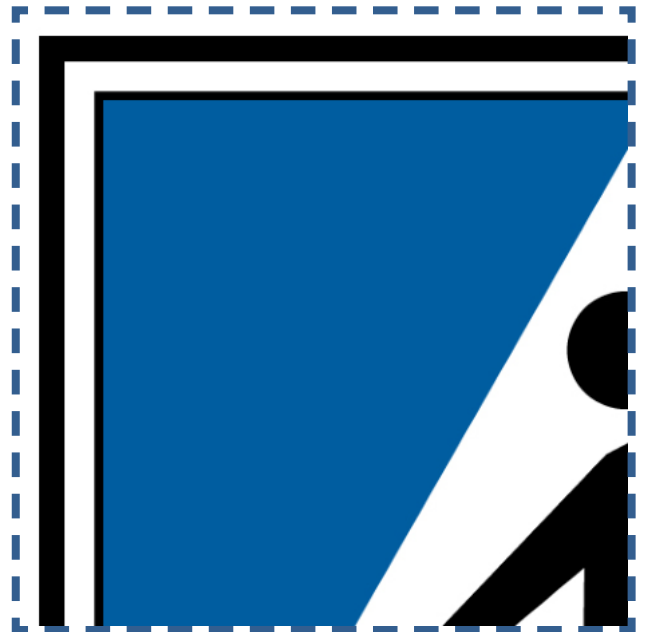



Recorta y reconstruye la señal.

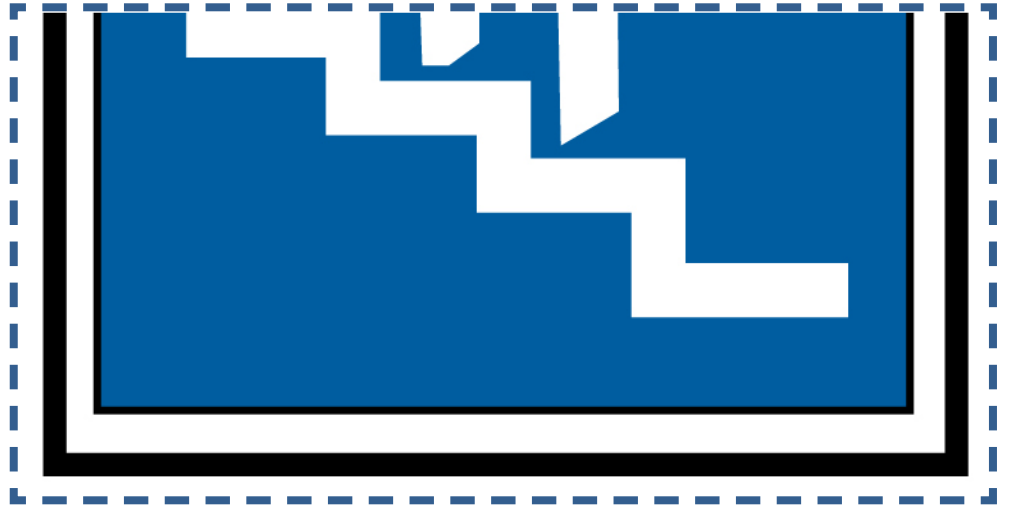



Recorta y reconstruye la señal.

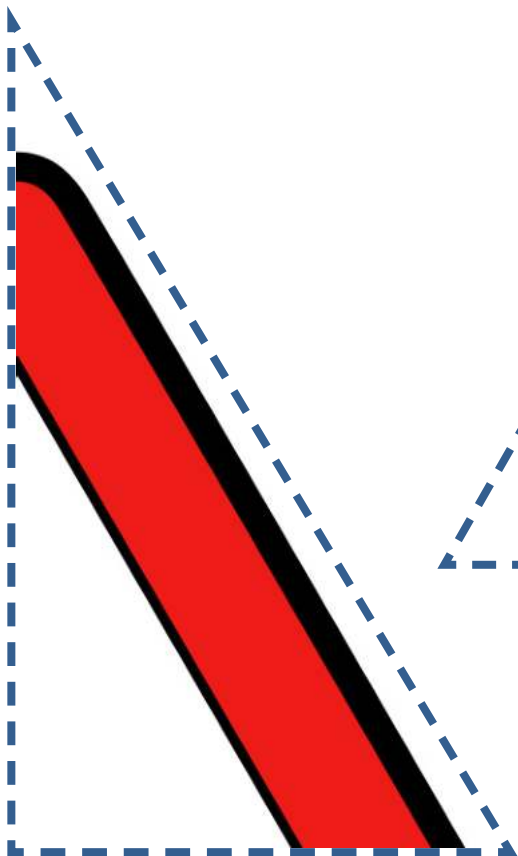





Recorta y reconstruye la señal.





Recorta las imágenes y pégalas sobre la forma que corresponda en la siguiente página.

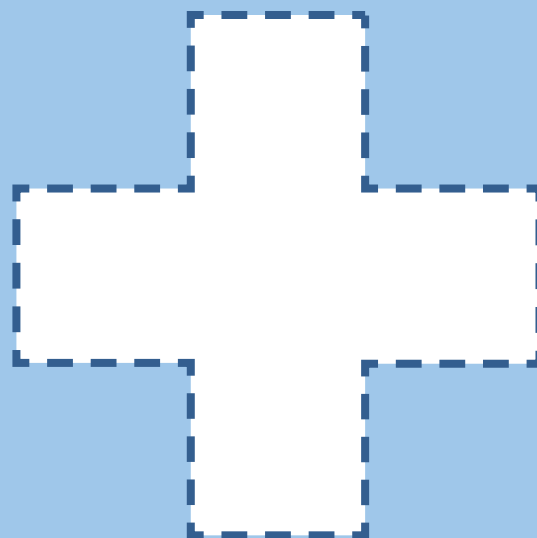
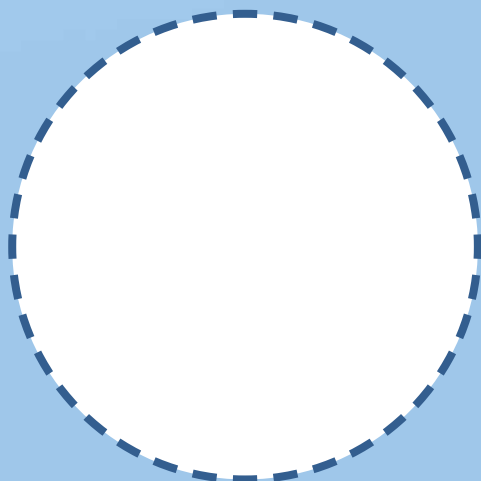
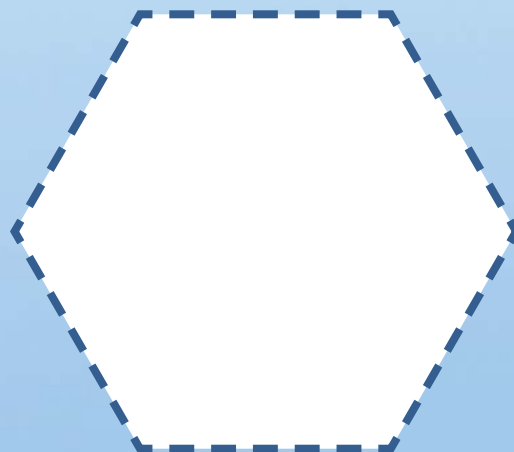

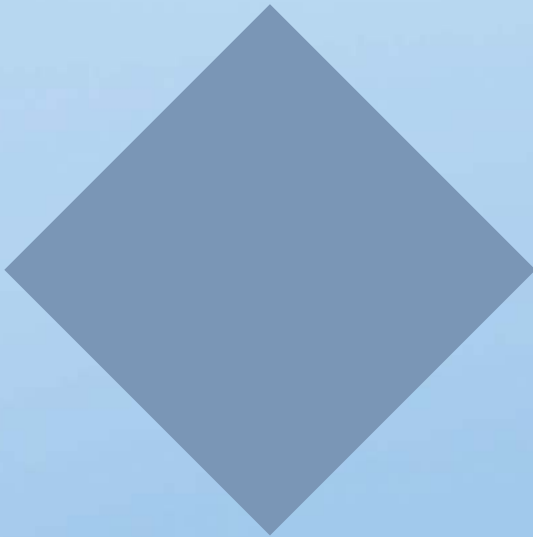
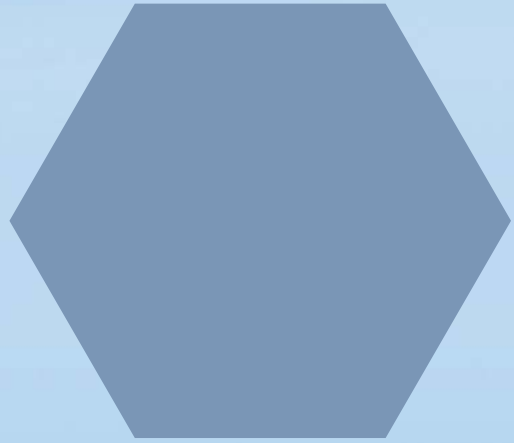
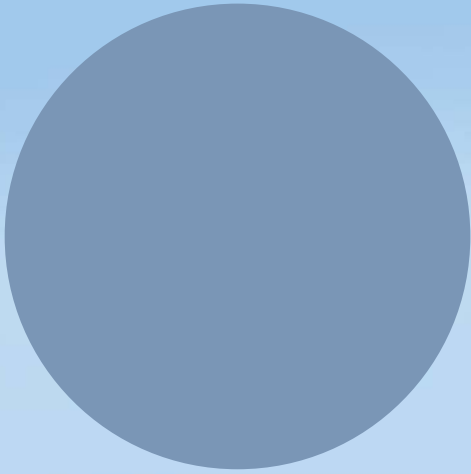



**Recorta las imágenes y pégalas sobre la forma que corresponda en la siguiente página.**

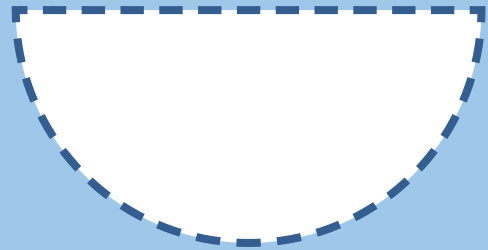
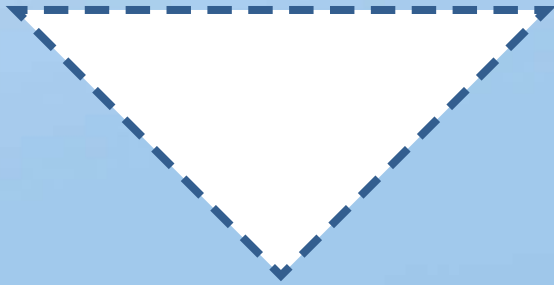

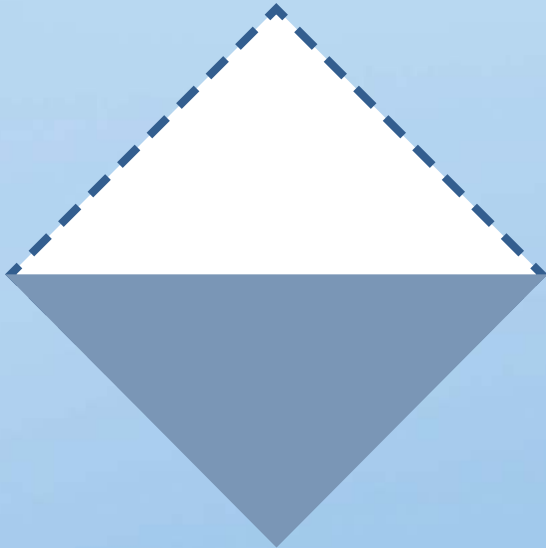
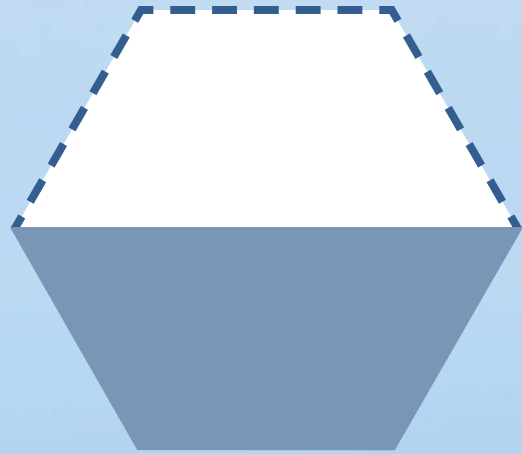
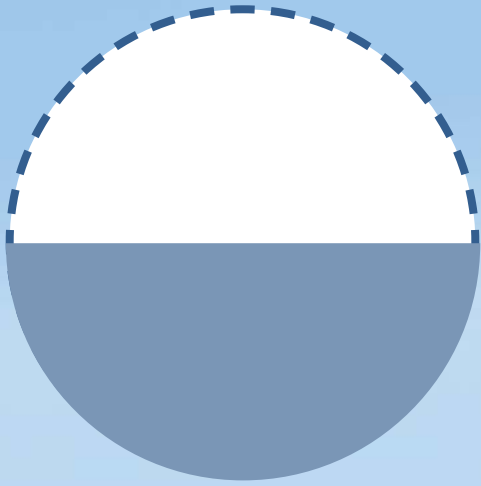



Recorta las imágenes y pégalas sobre la forma que corresponda en la siguiente página.

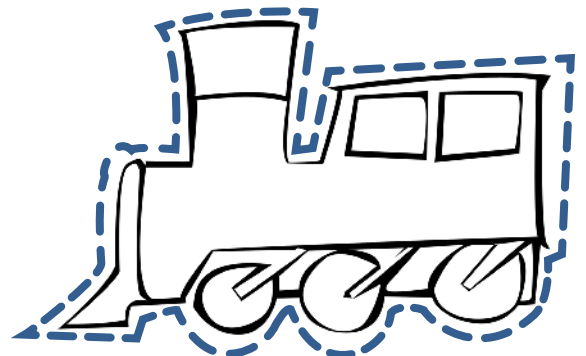
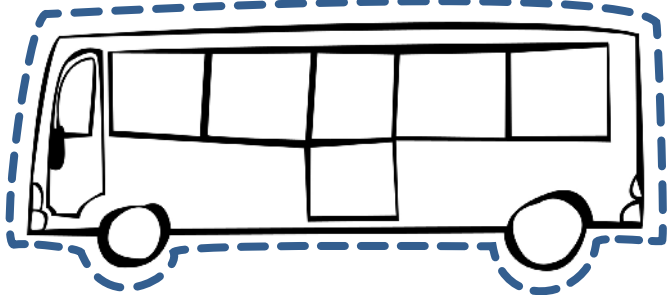
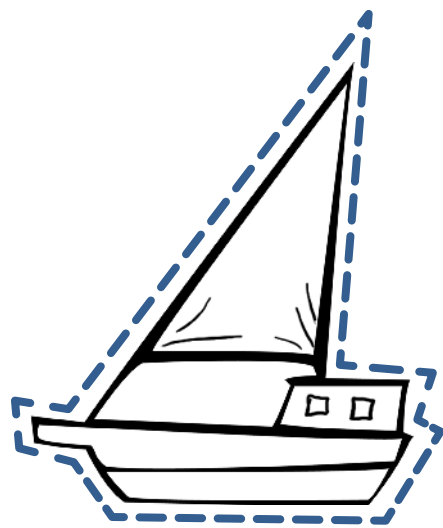
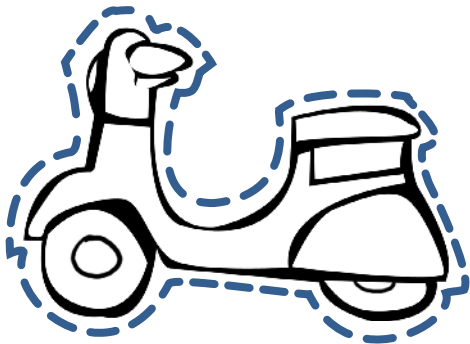
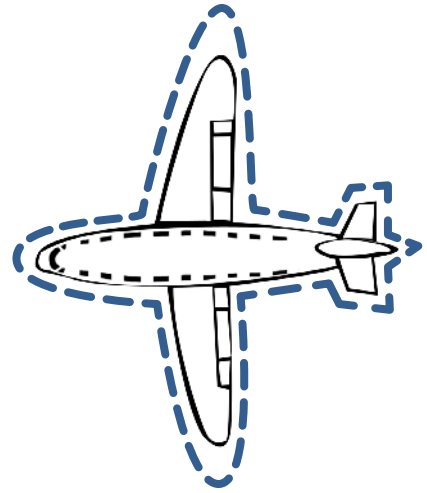
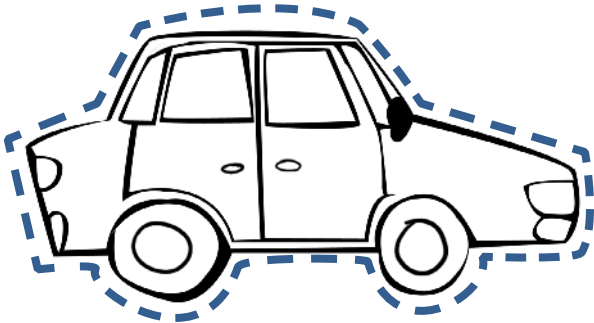

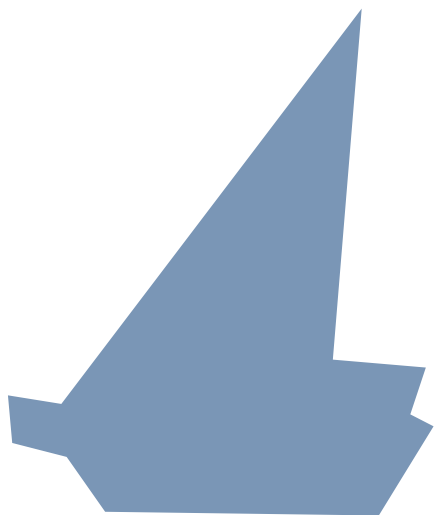
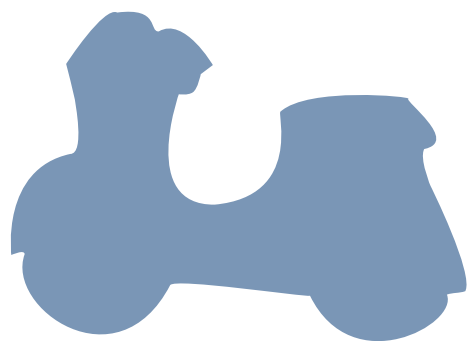
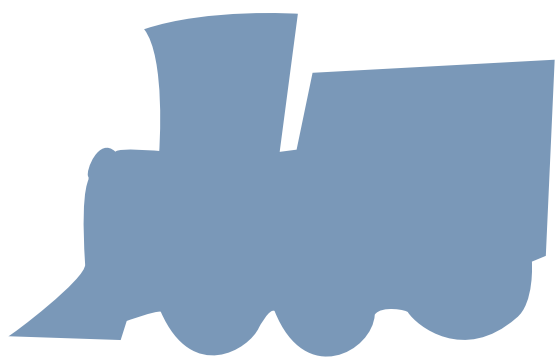



**Recorta las imágenes y pégalas sobre la forma que corresponda en la siguiente página.**

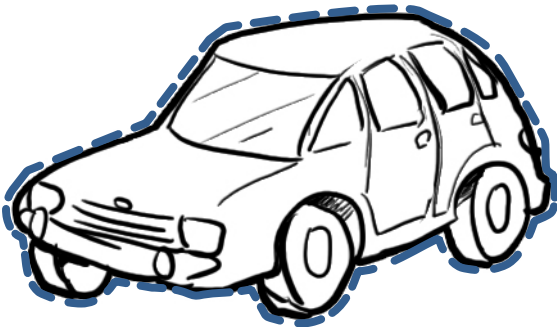
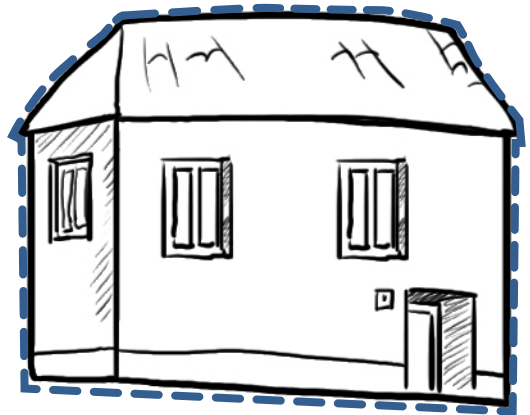



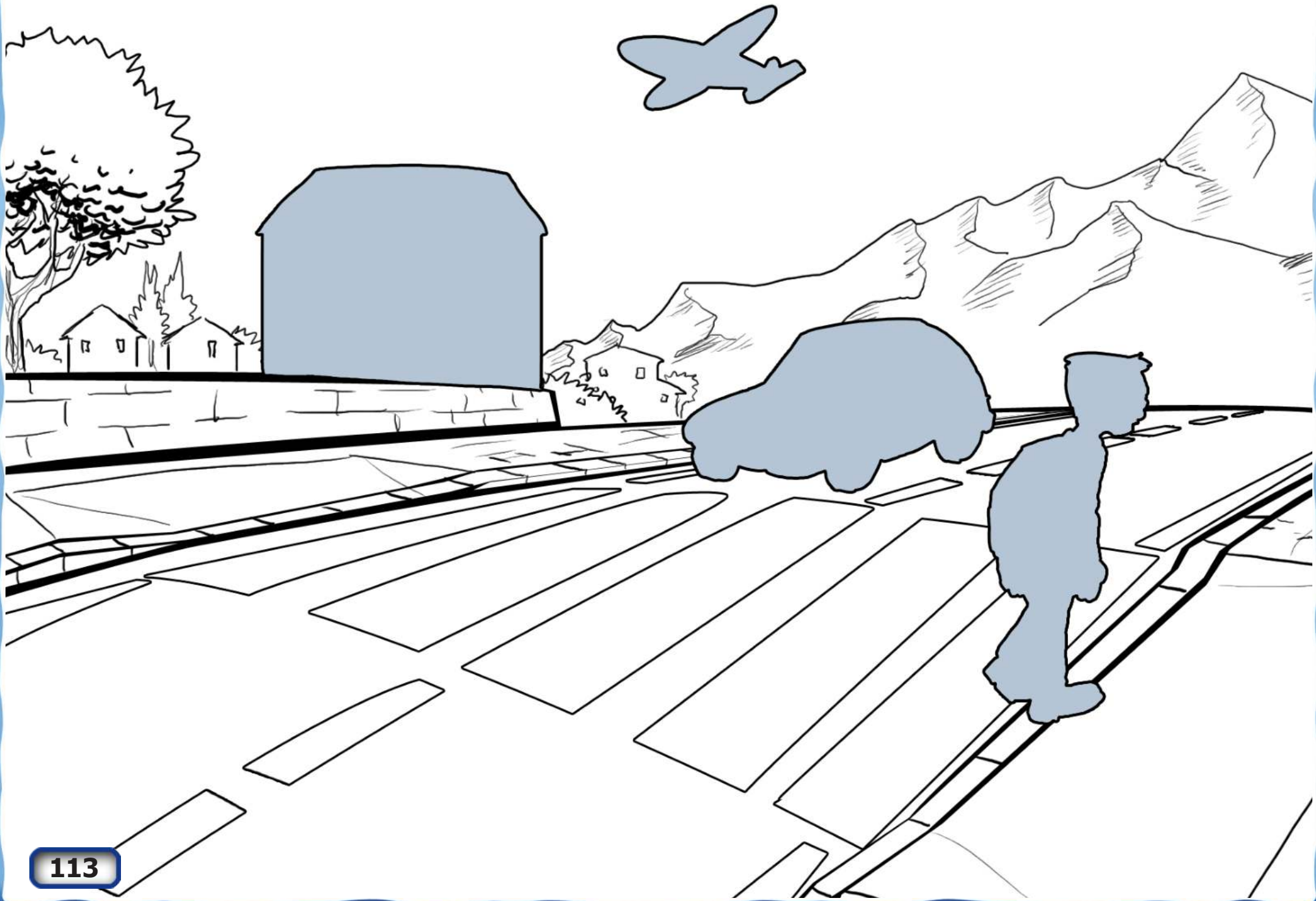



Completa la imagen.



★ Completa la imagen.

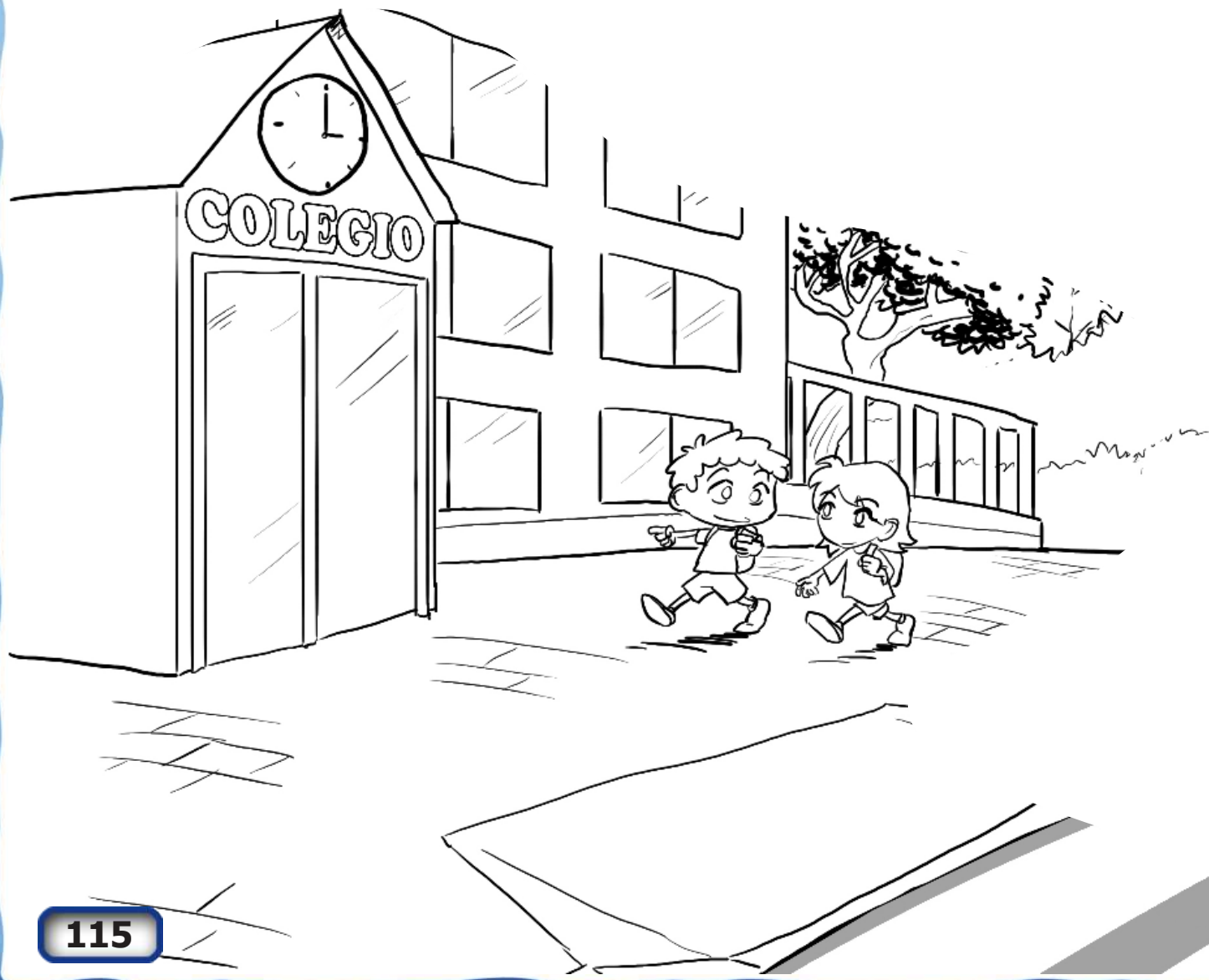

★ Completa la imagen.



★ Completa la imagen.



★ Recorta y juega al dominó.

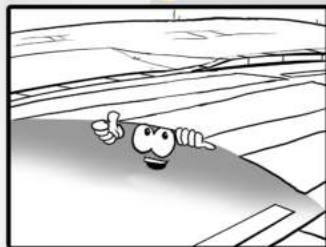
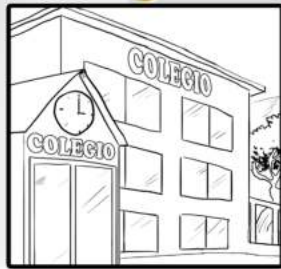

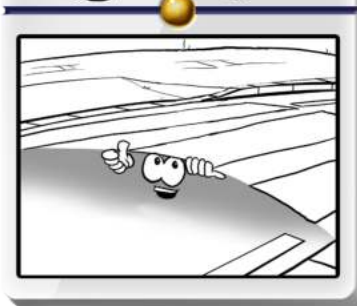
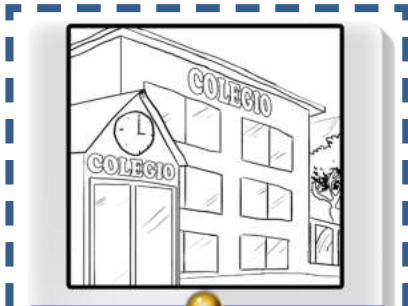
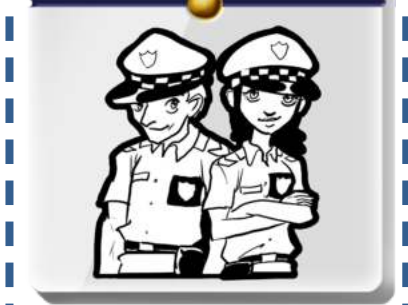

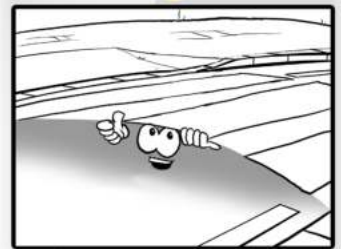
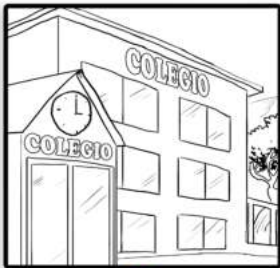
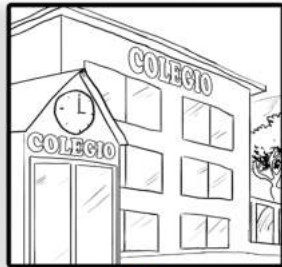
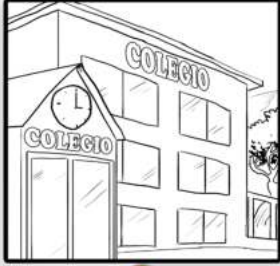
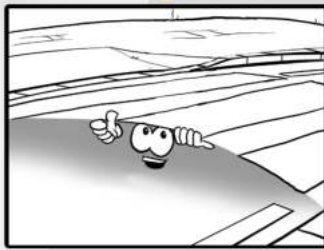
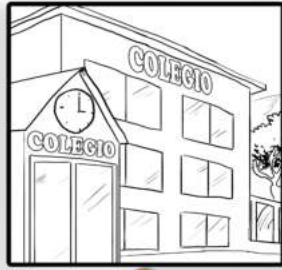



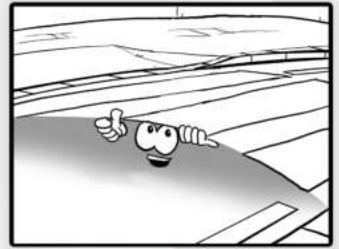
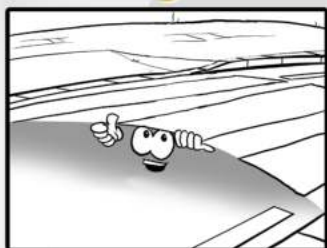
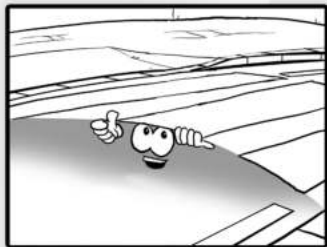
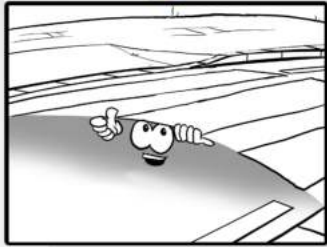



**Personas:**

Imprime y colorea.









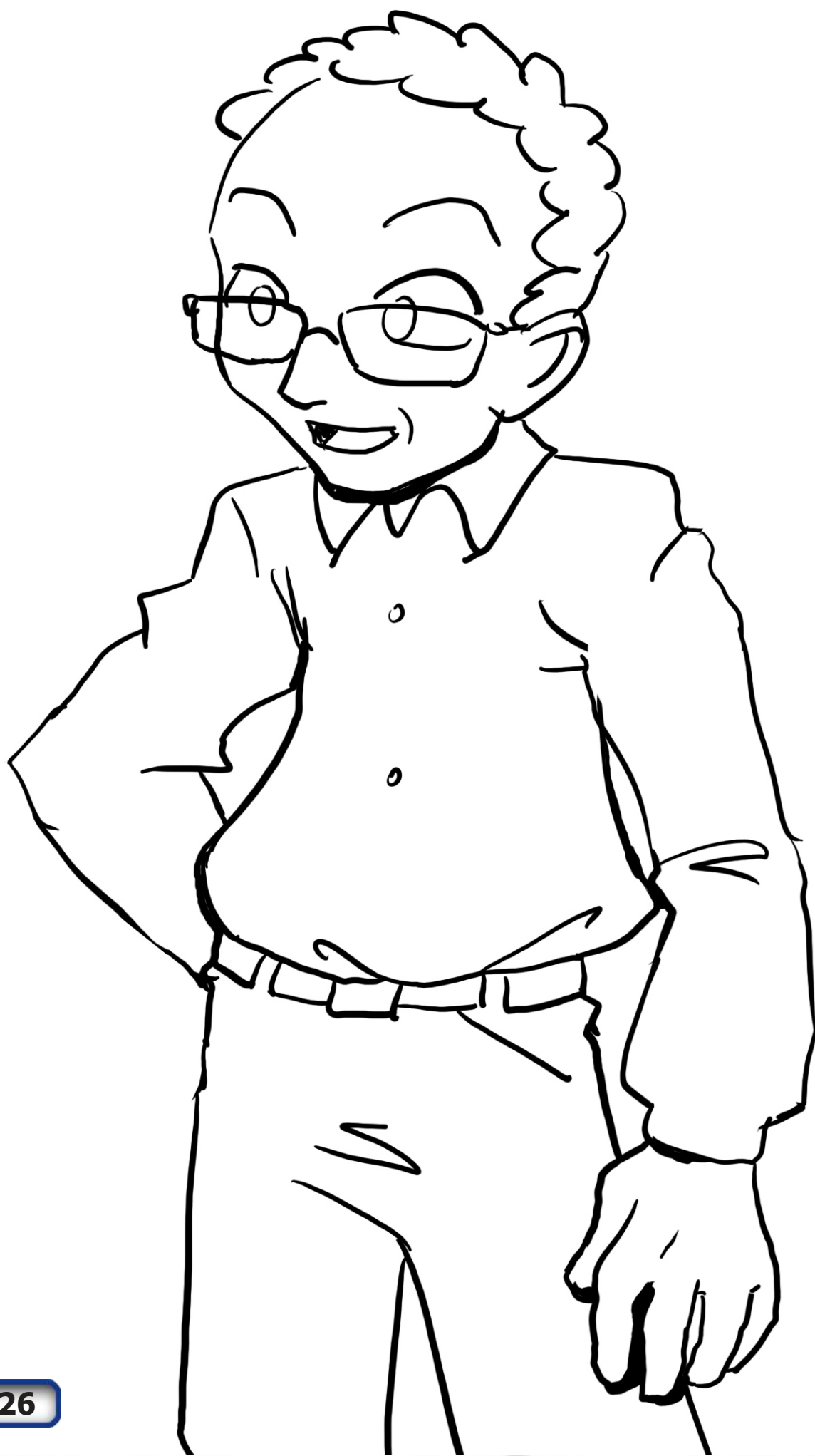

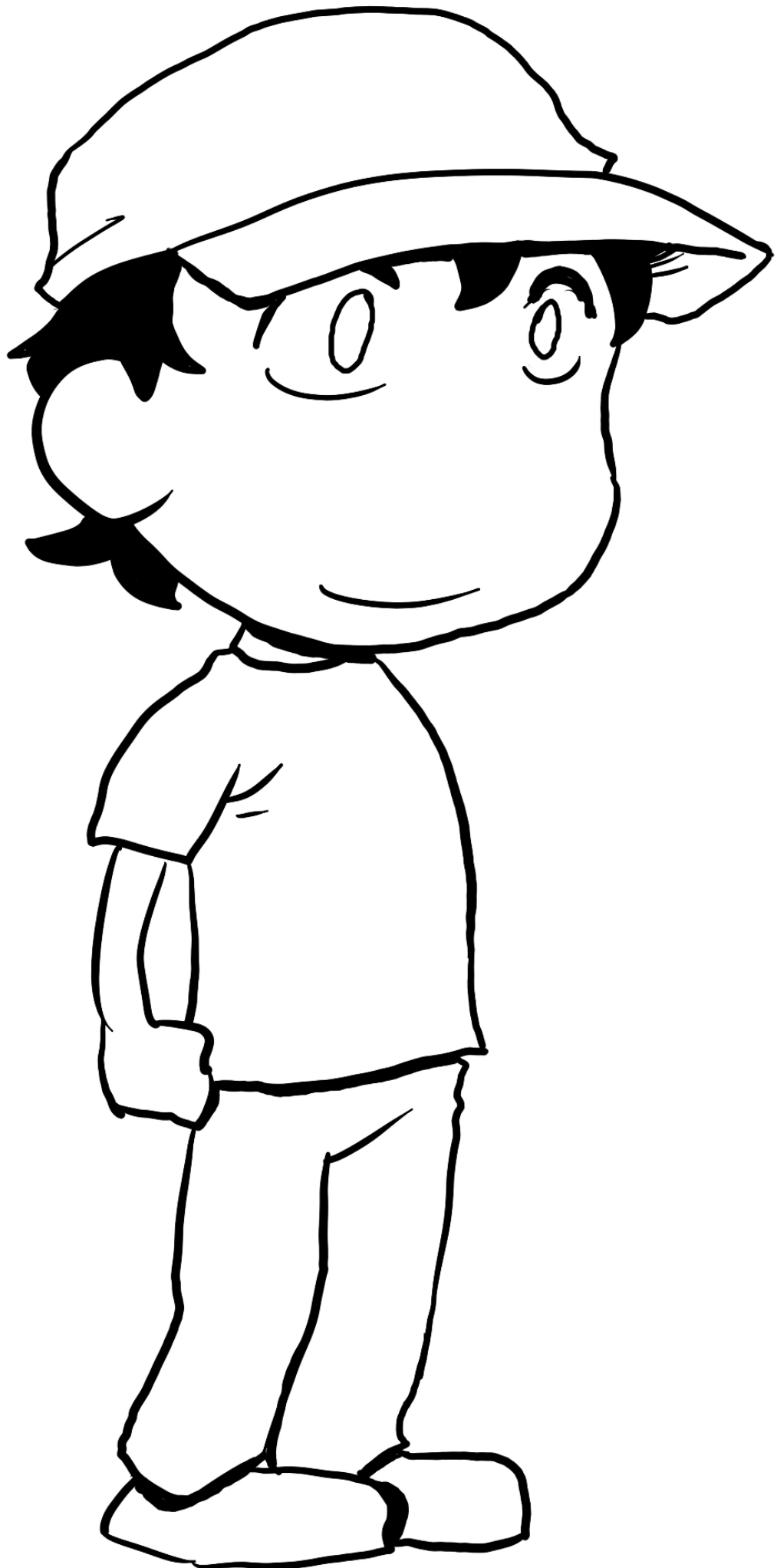



**Señales:**

Imprime y colorea.

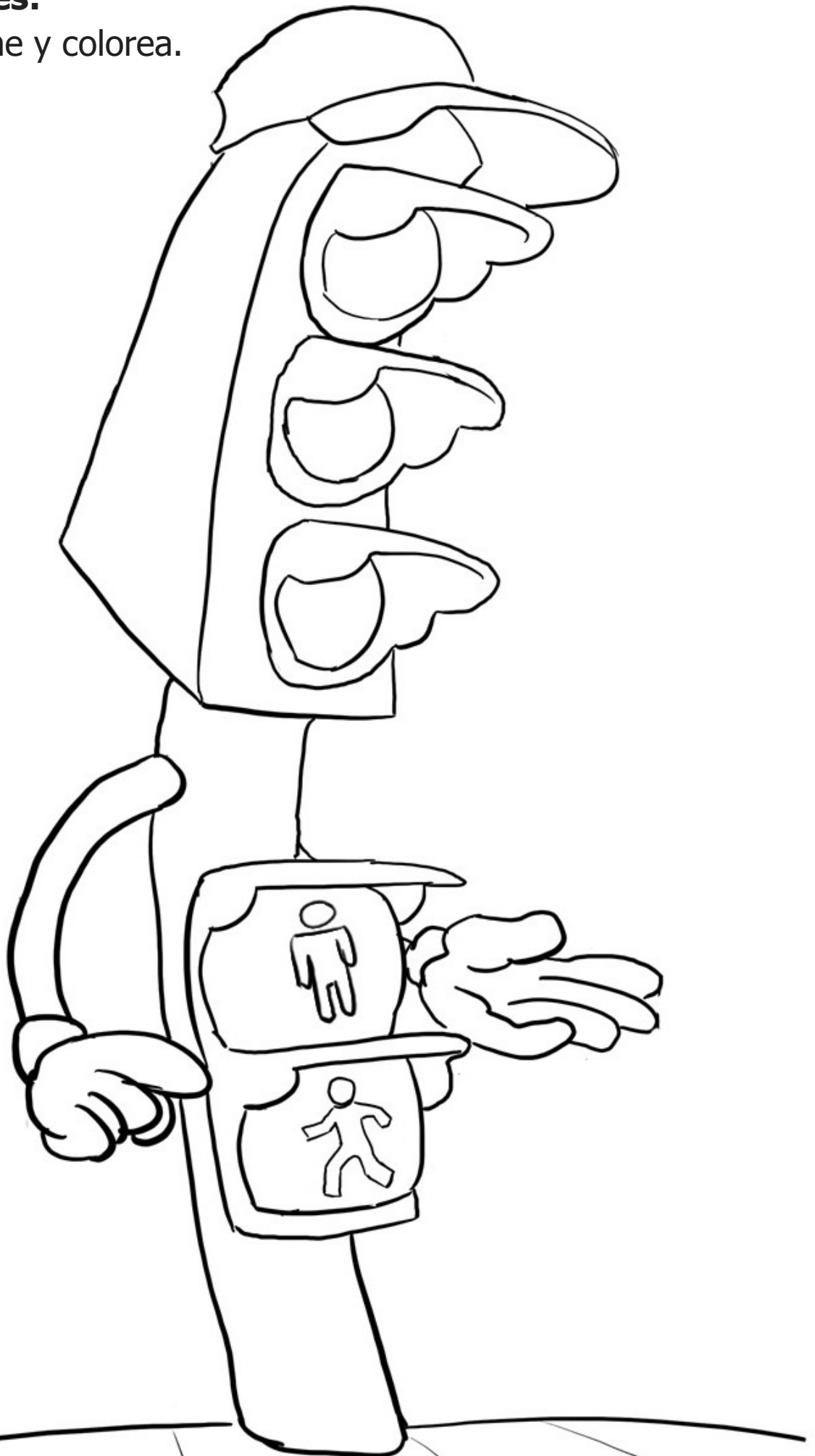



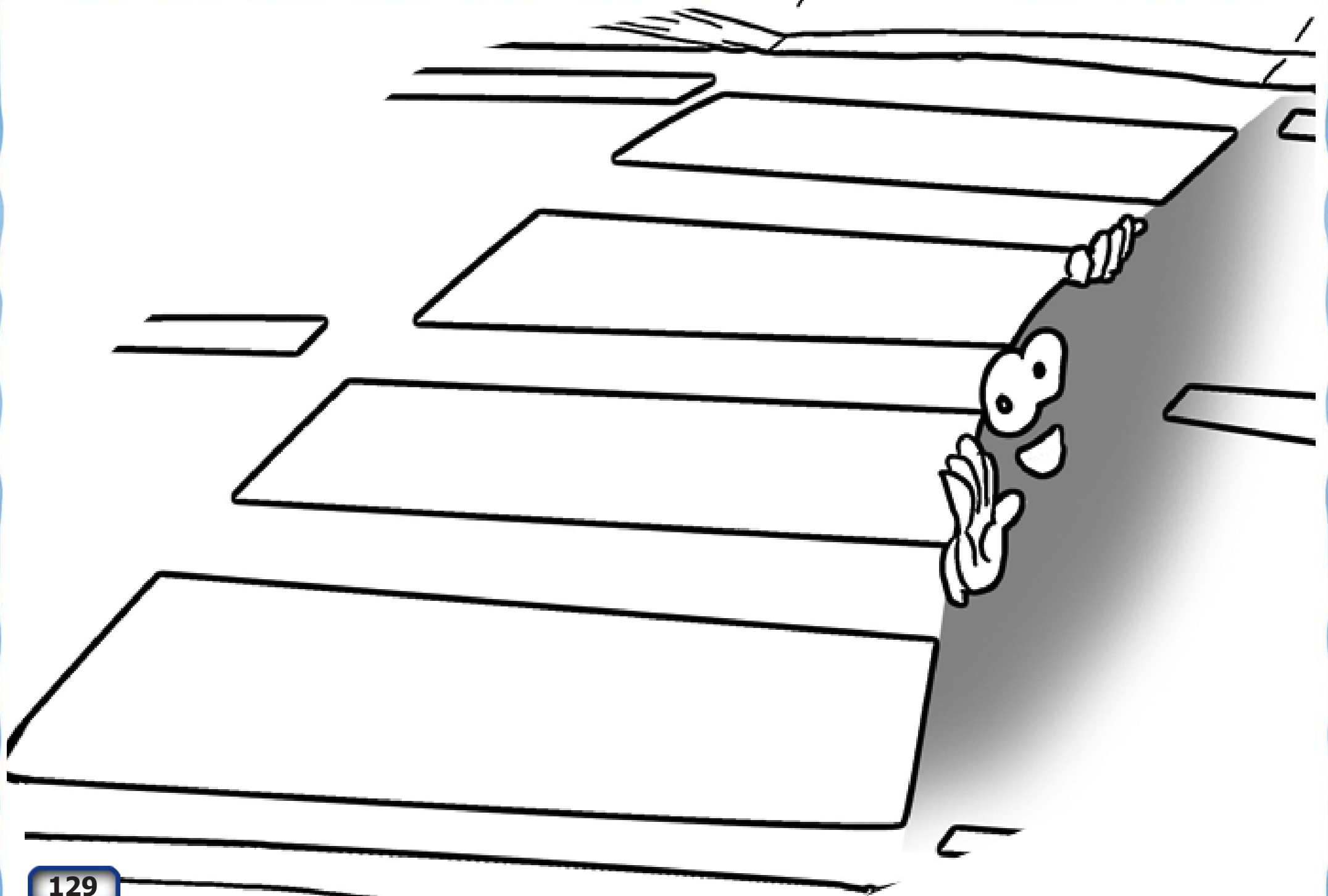

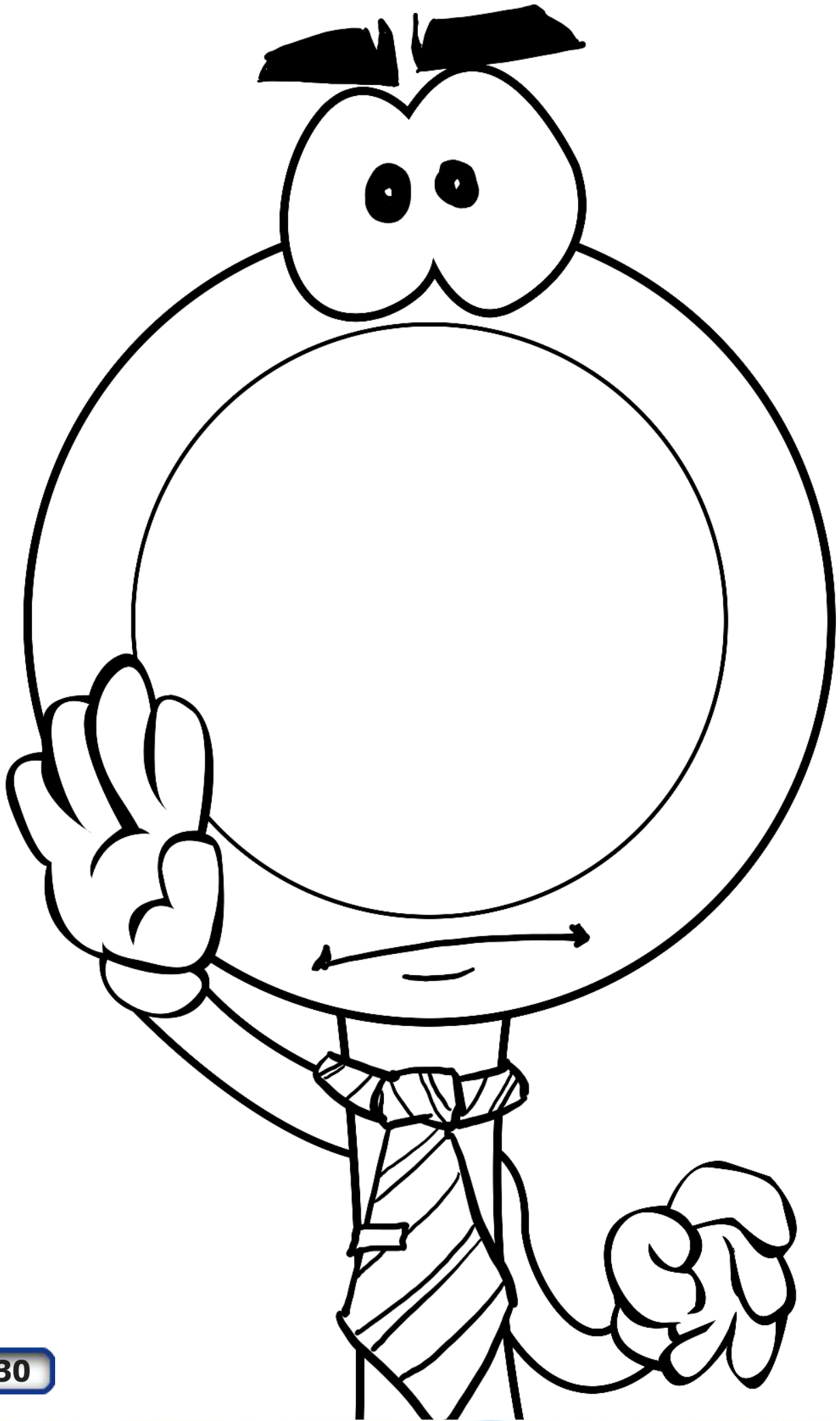

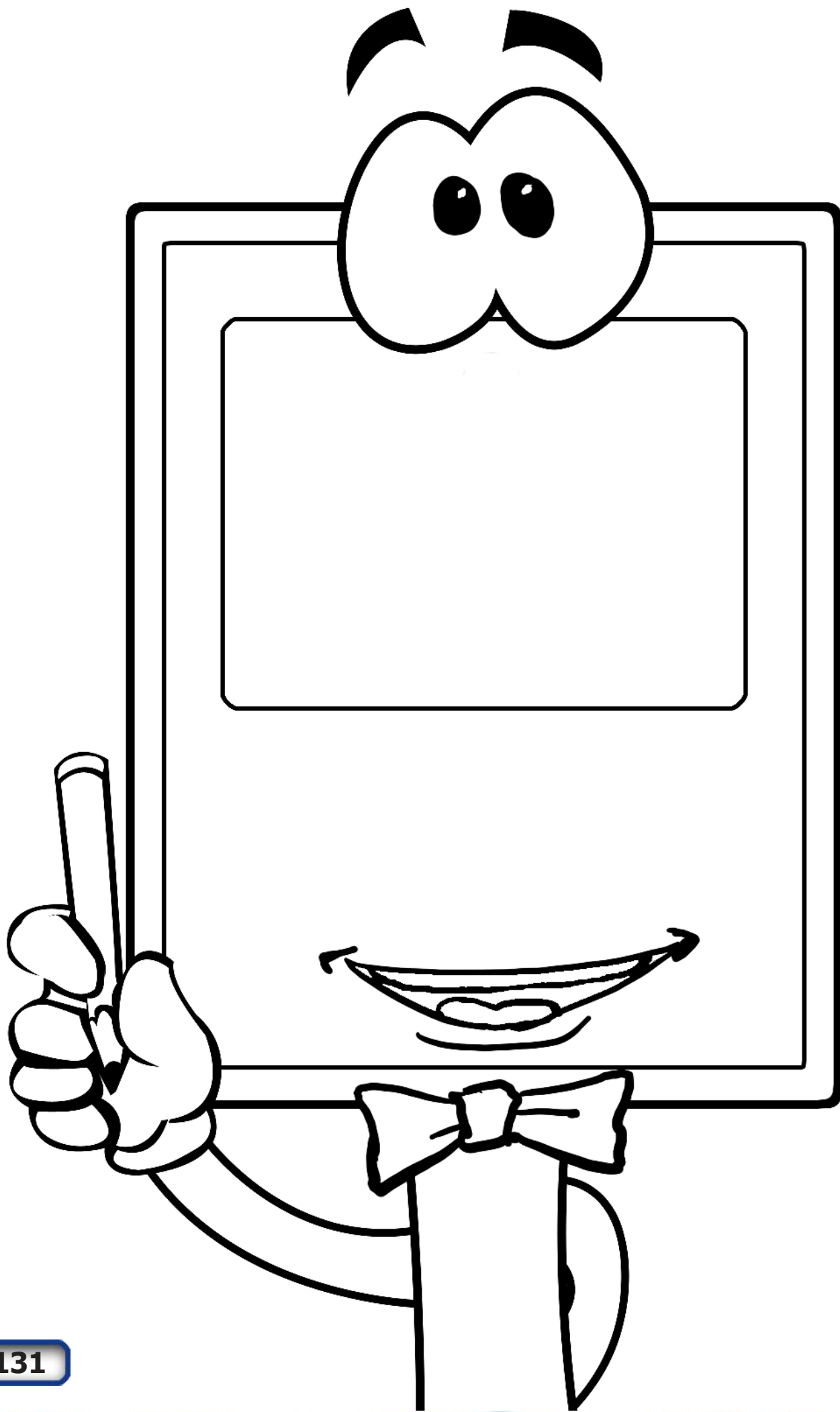

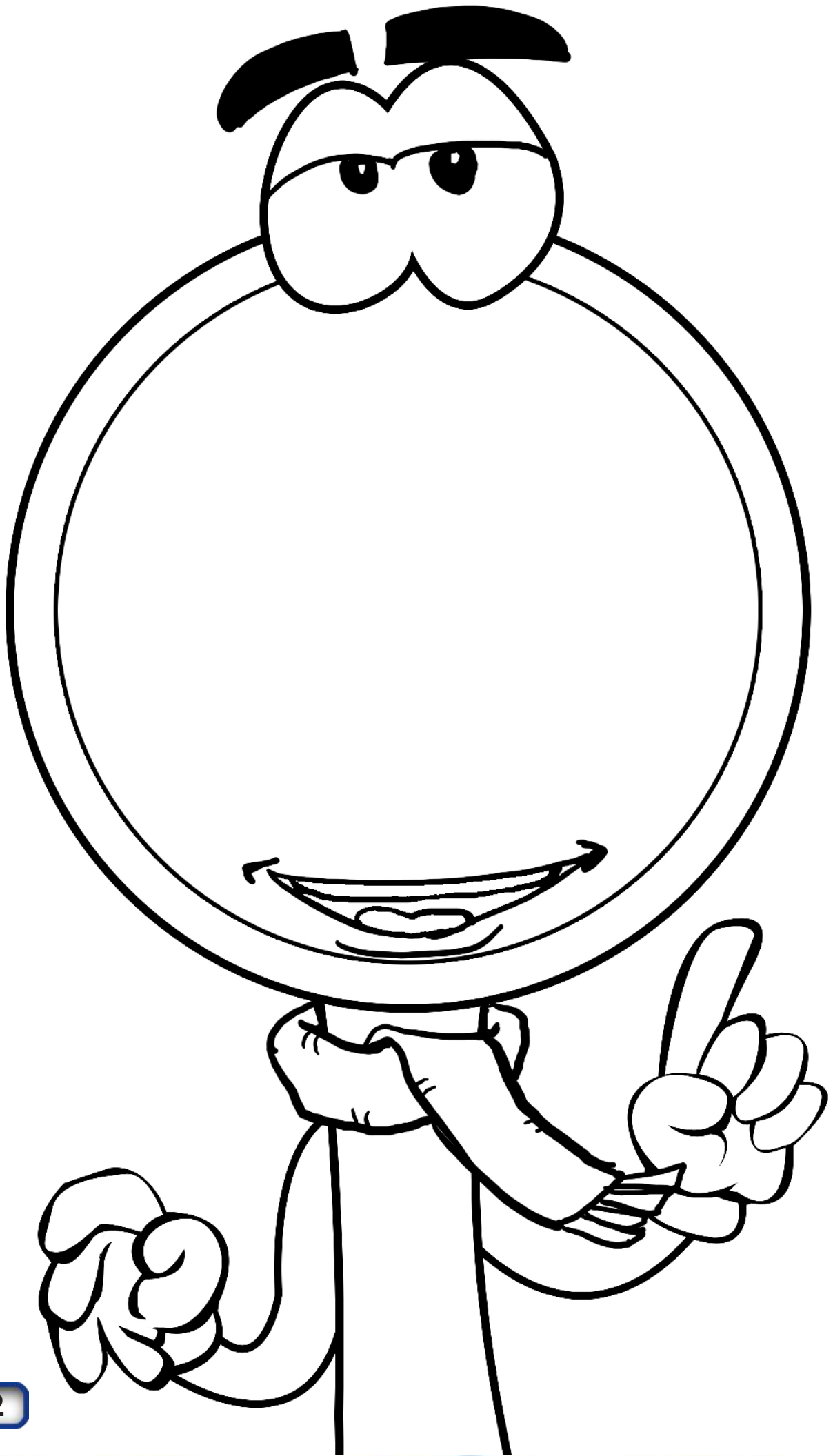

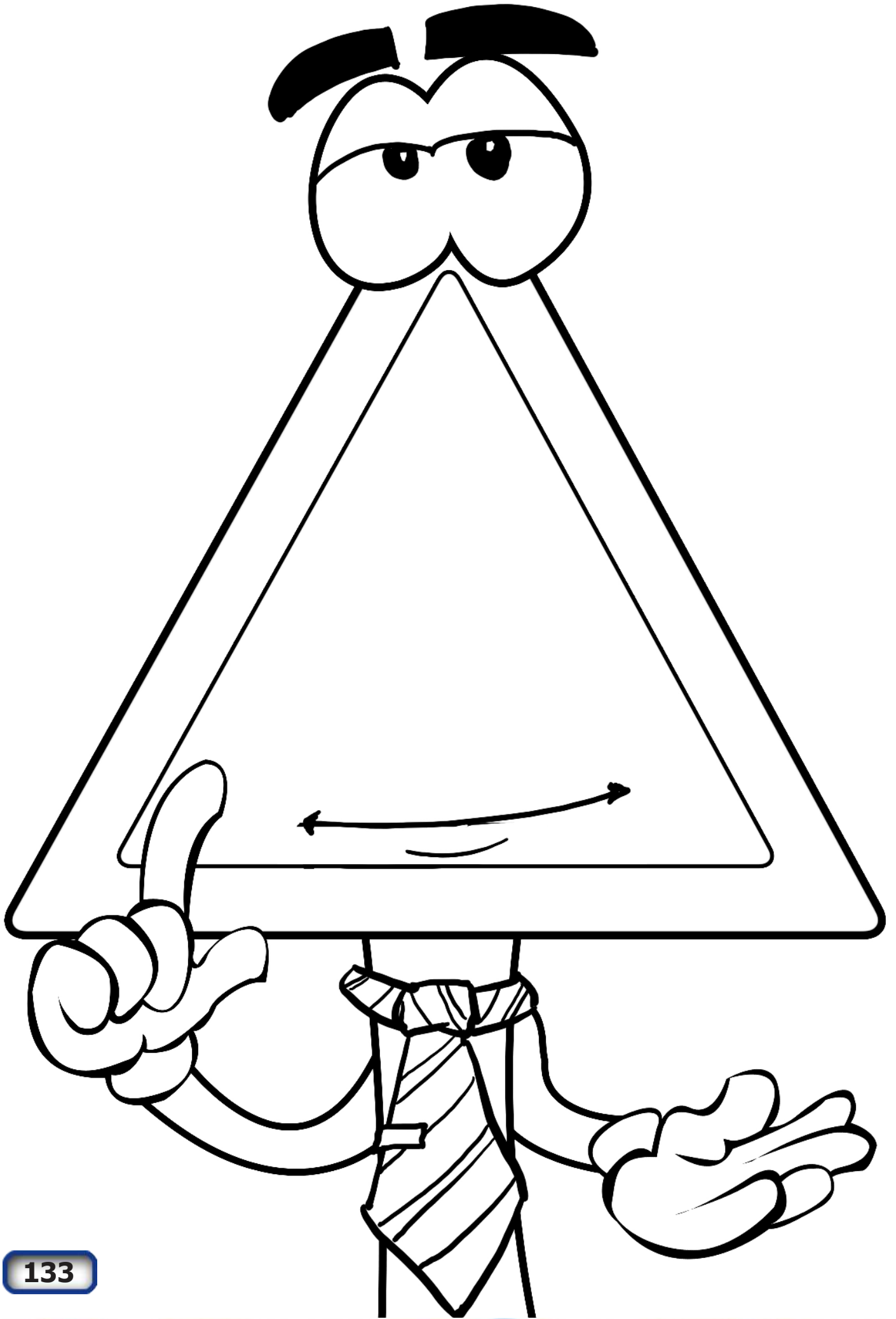



# Vehículos:

Imprime y colorea.

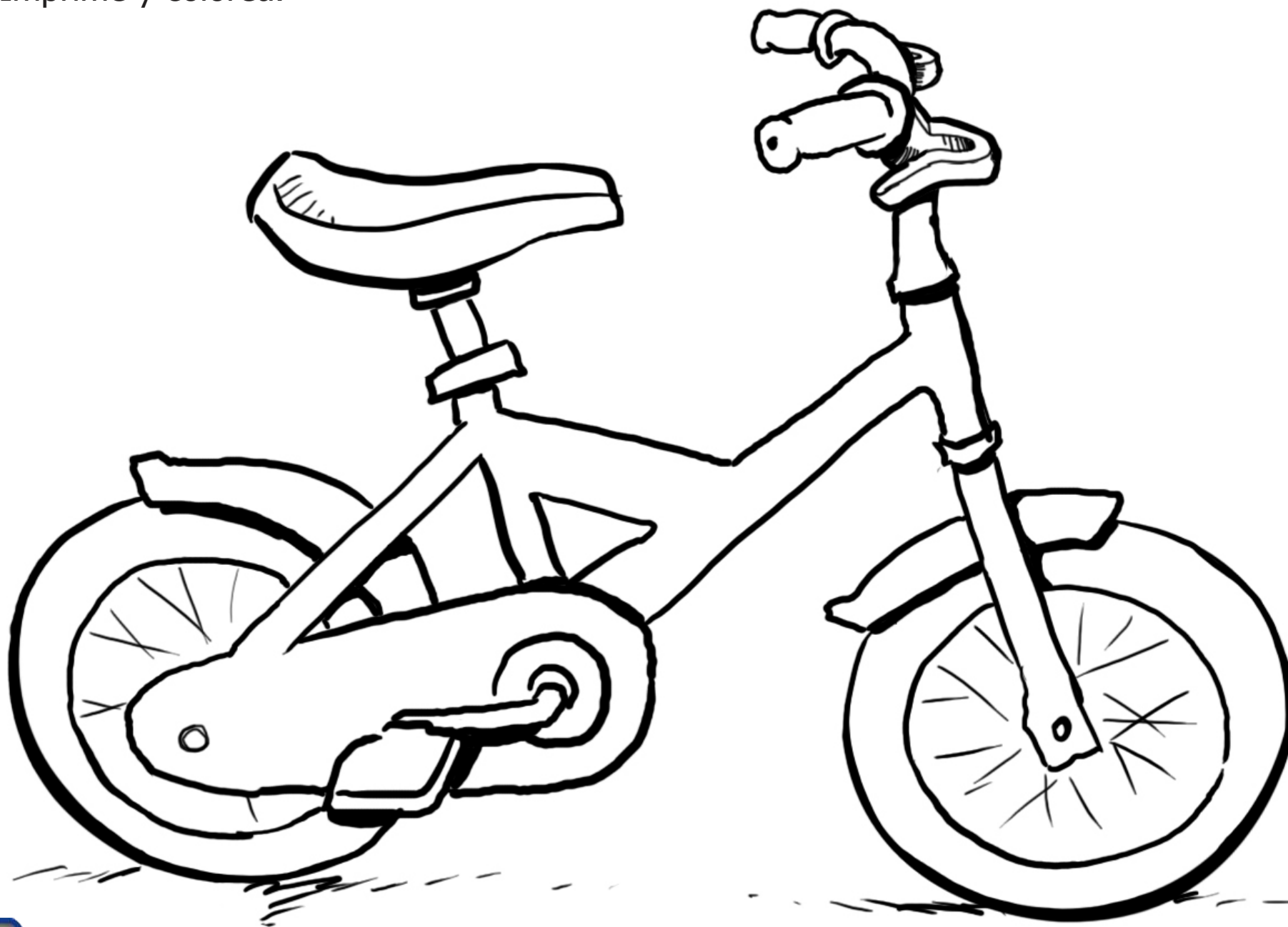

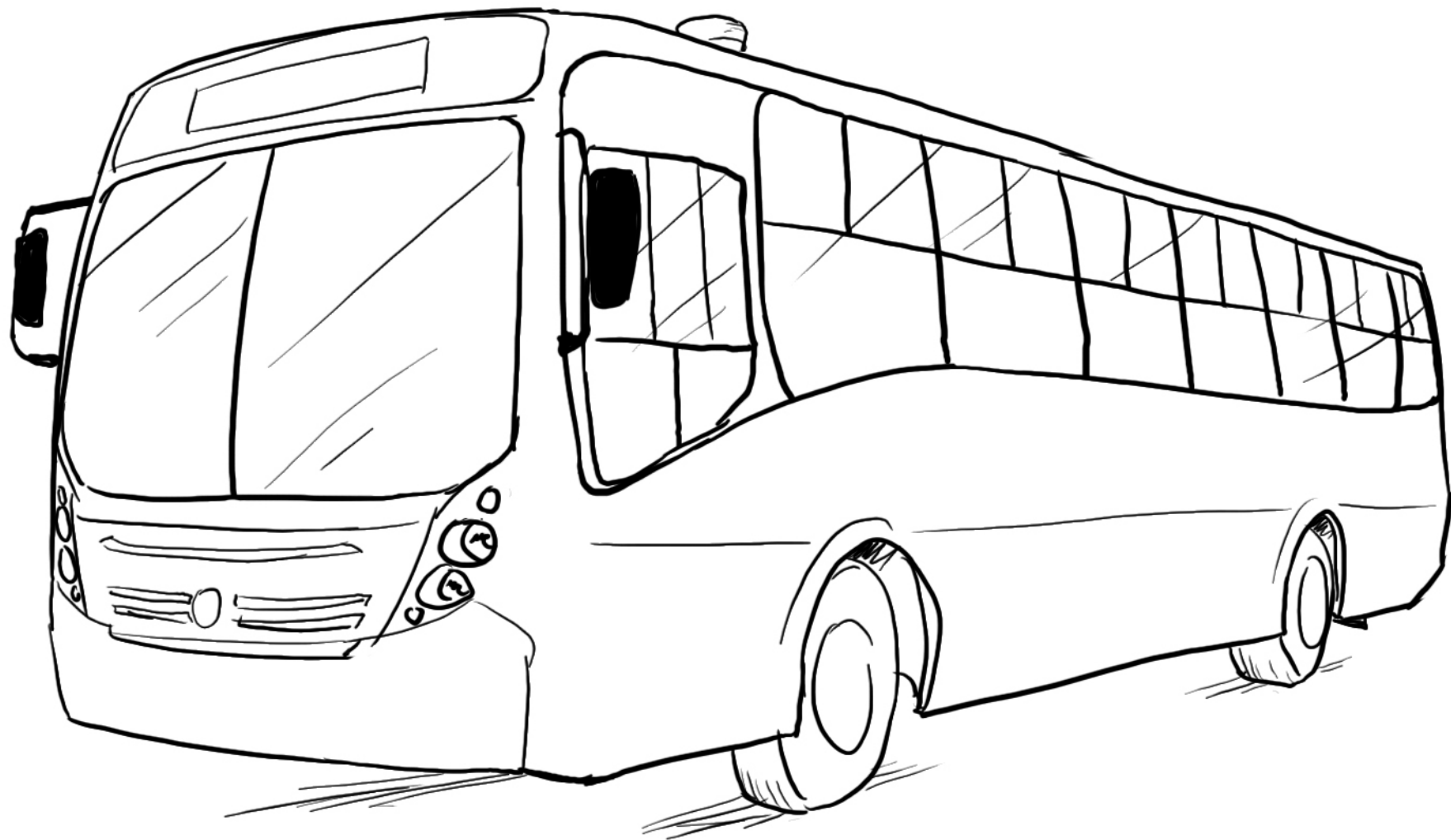

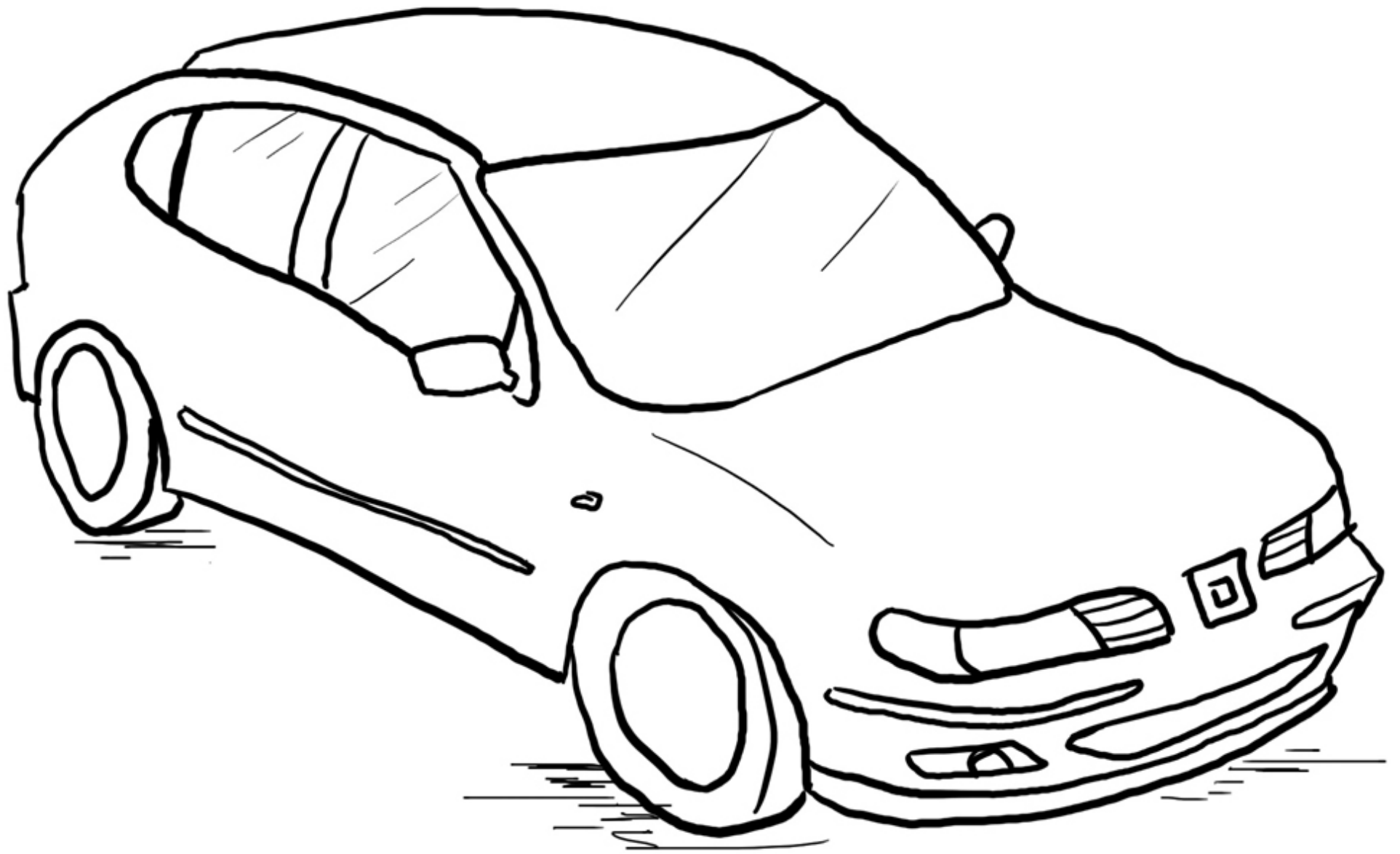





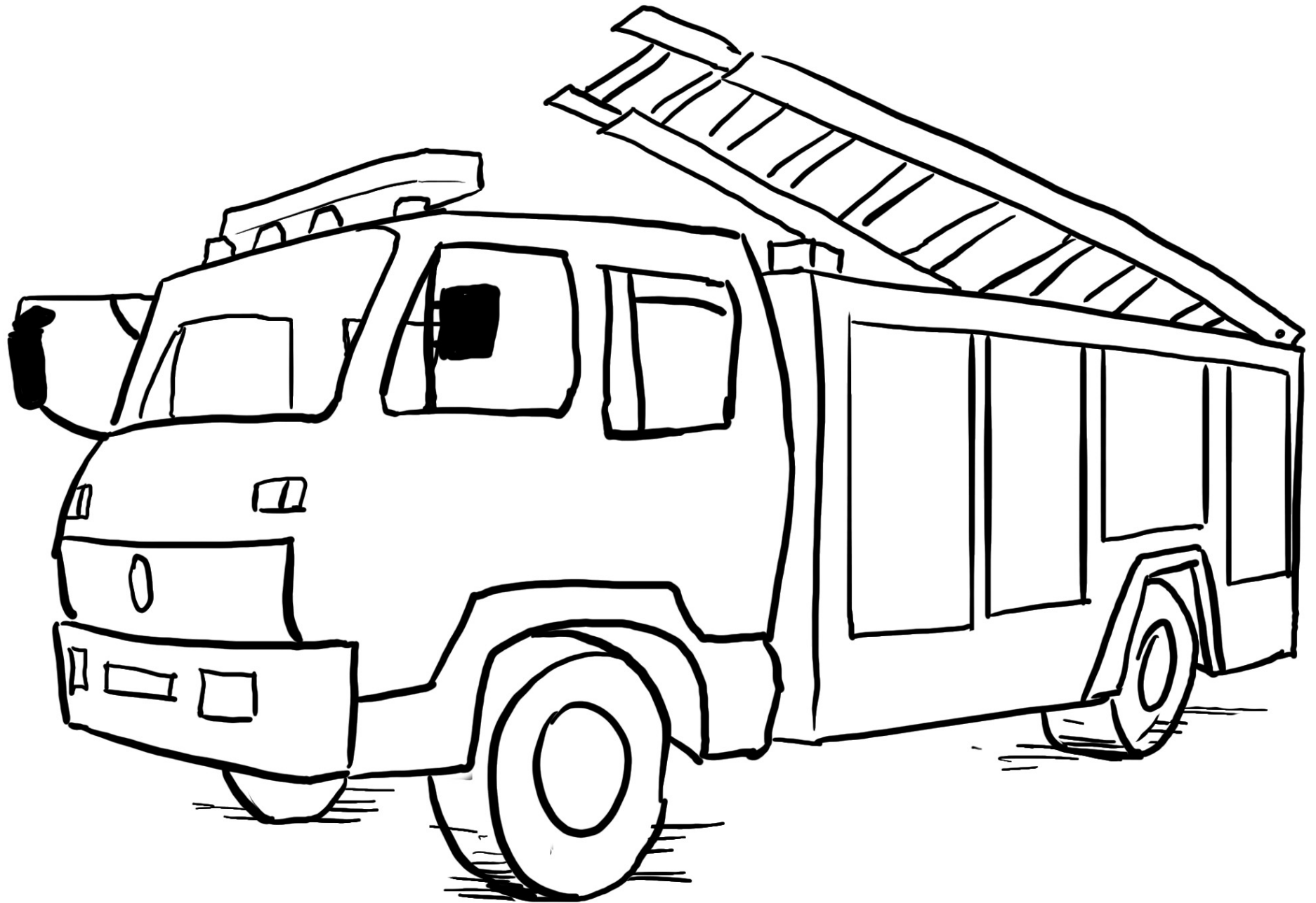

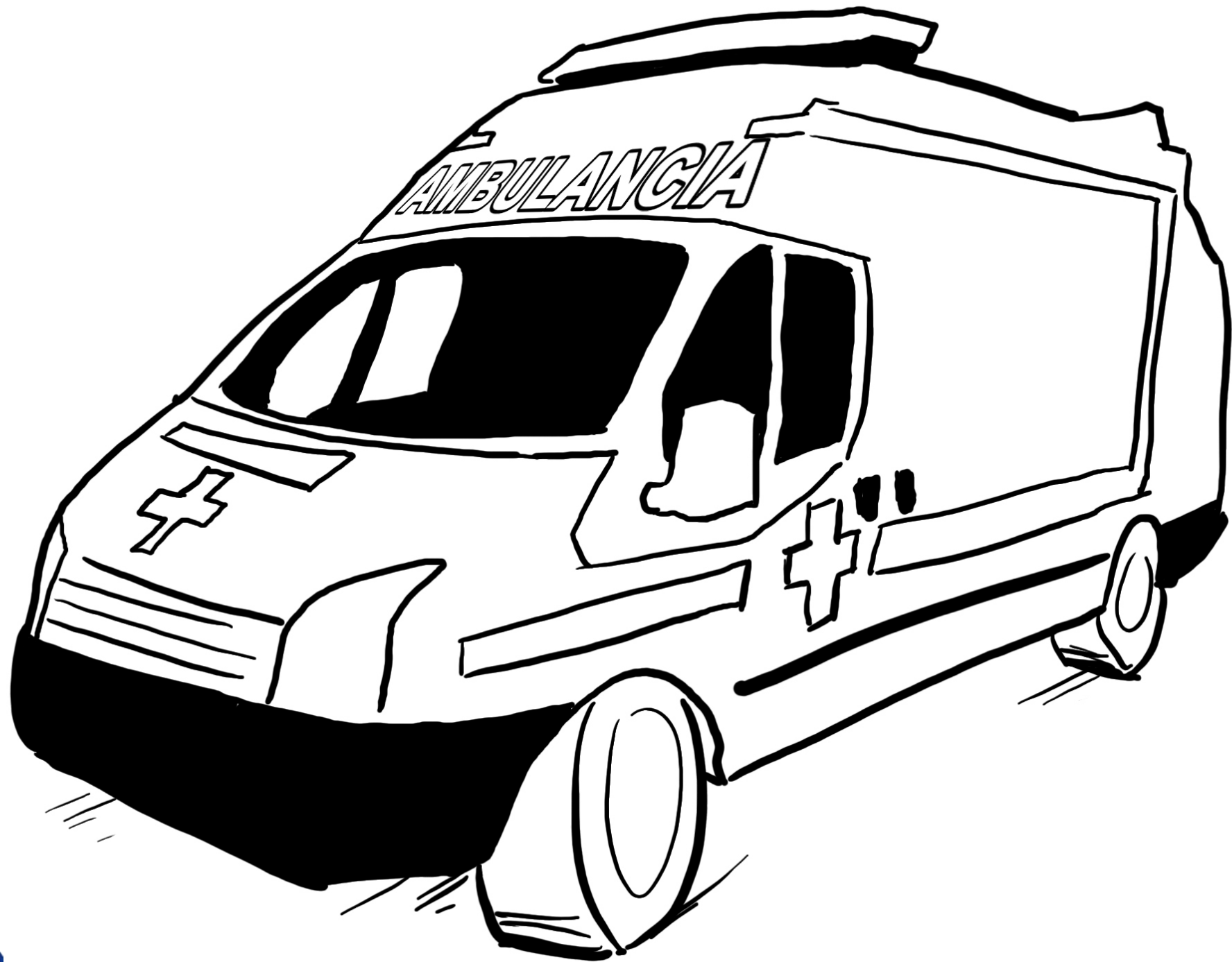



**Vías:**

Imprime y colorea.

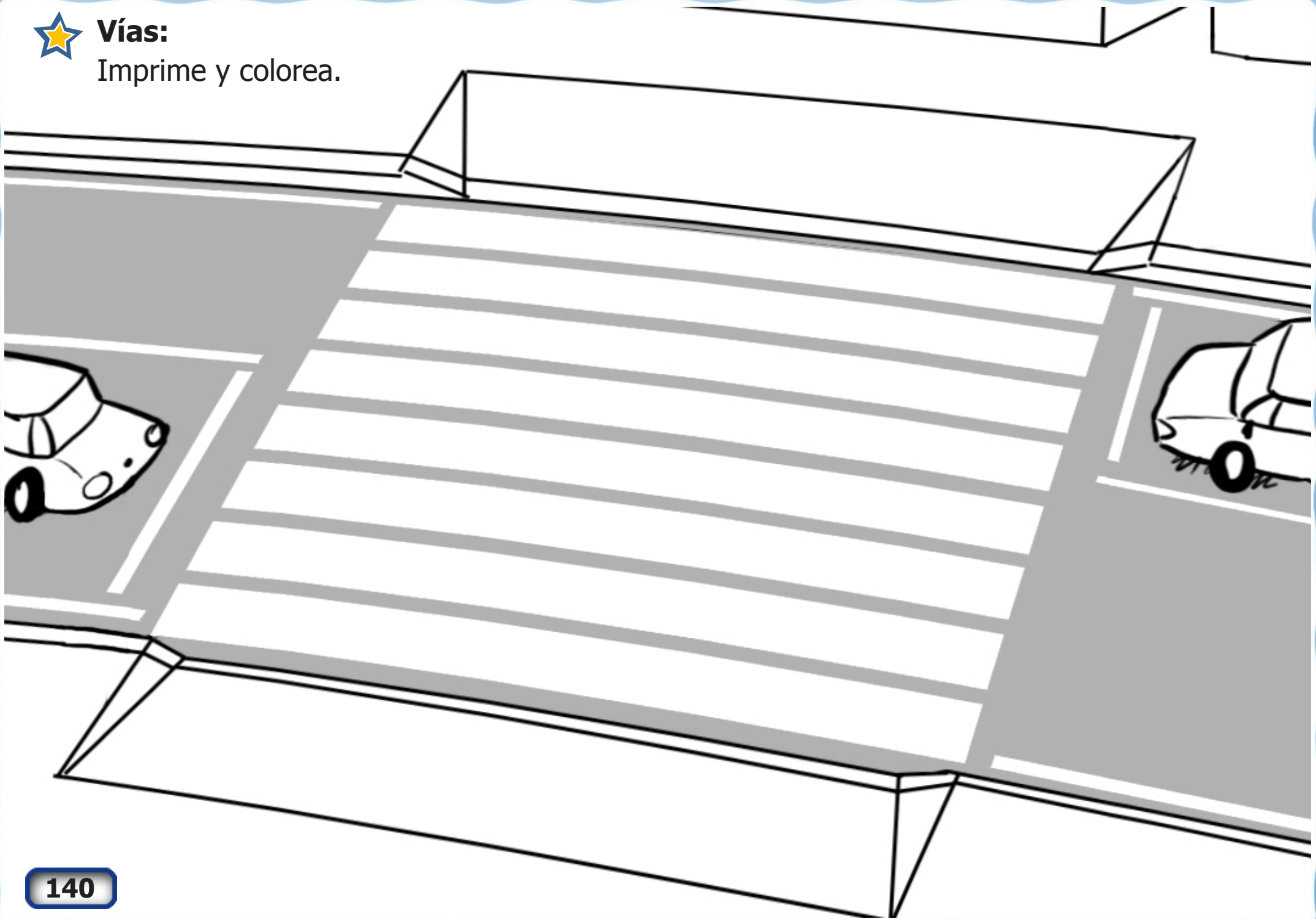

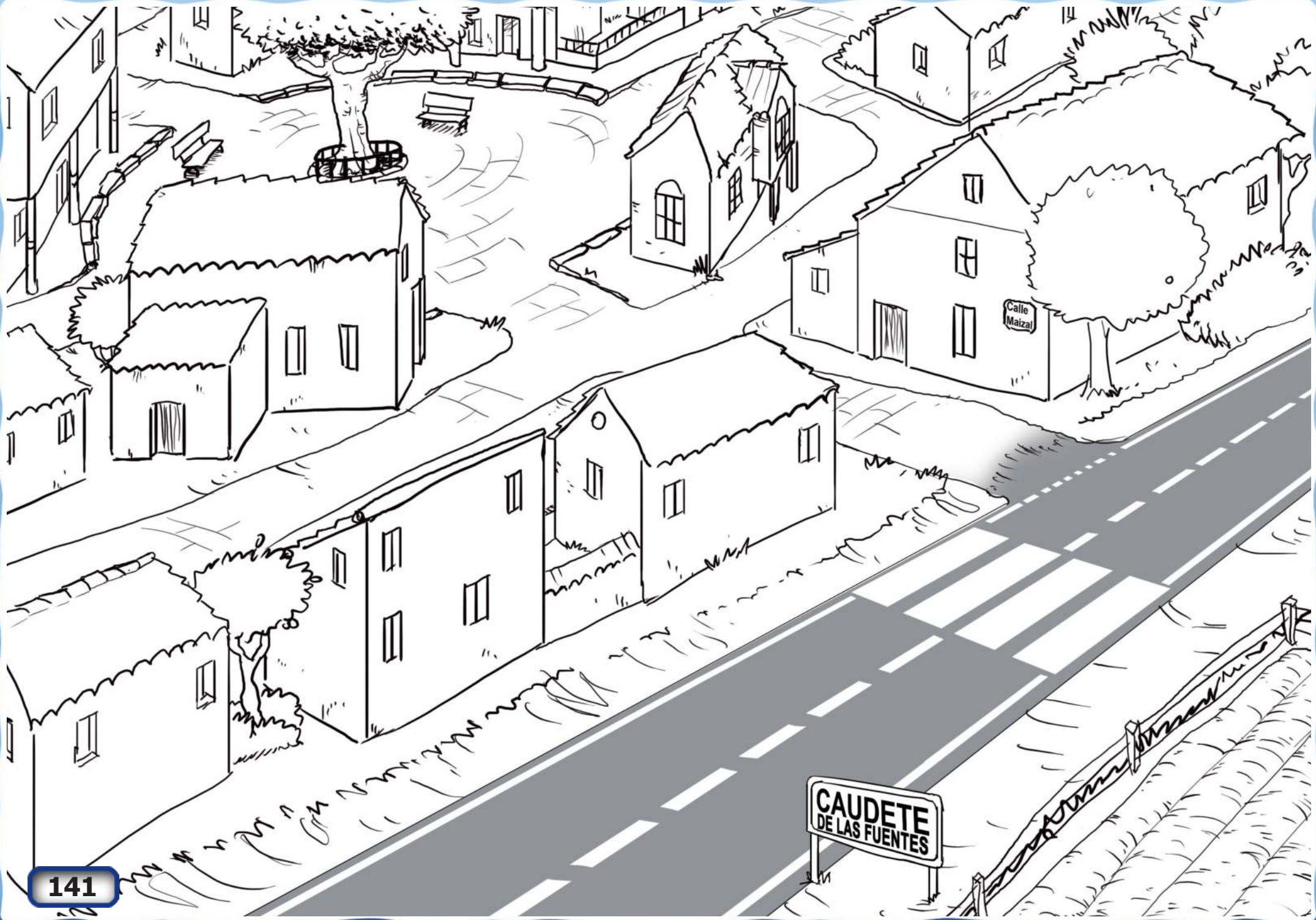



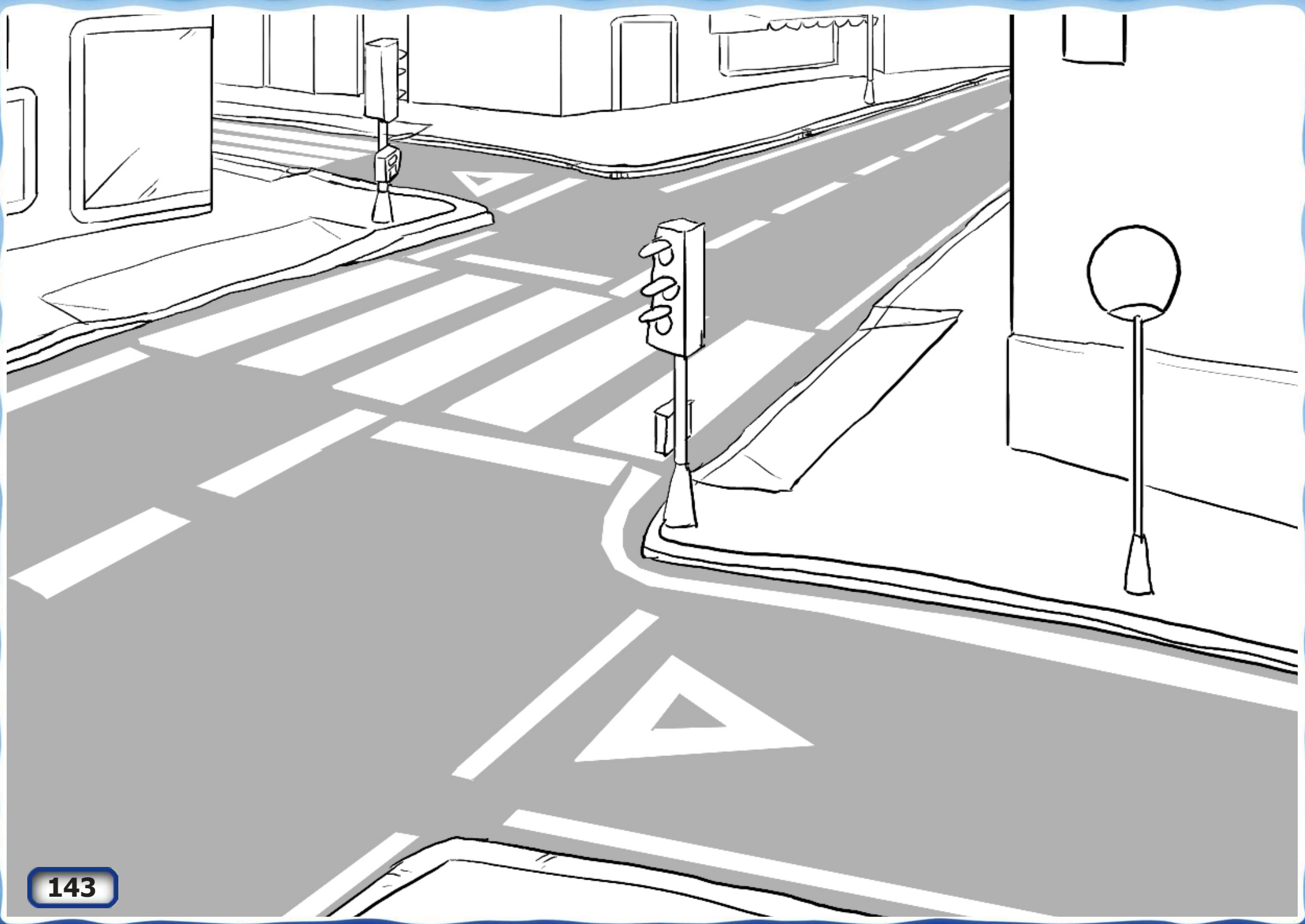

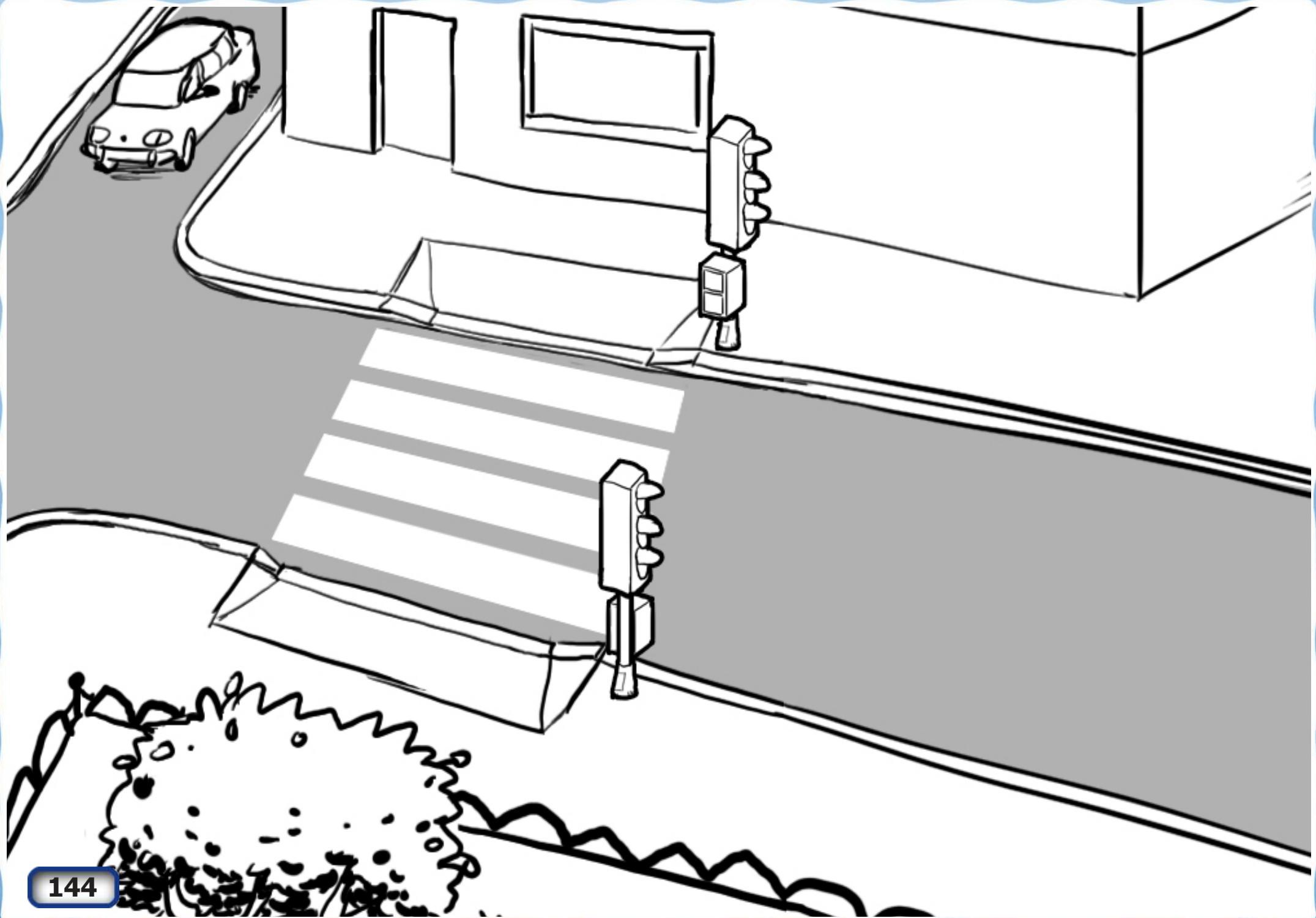



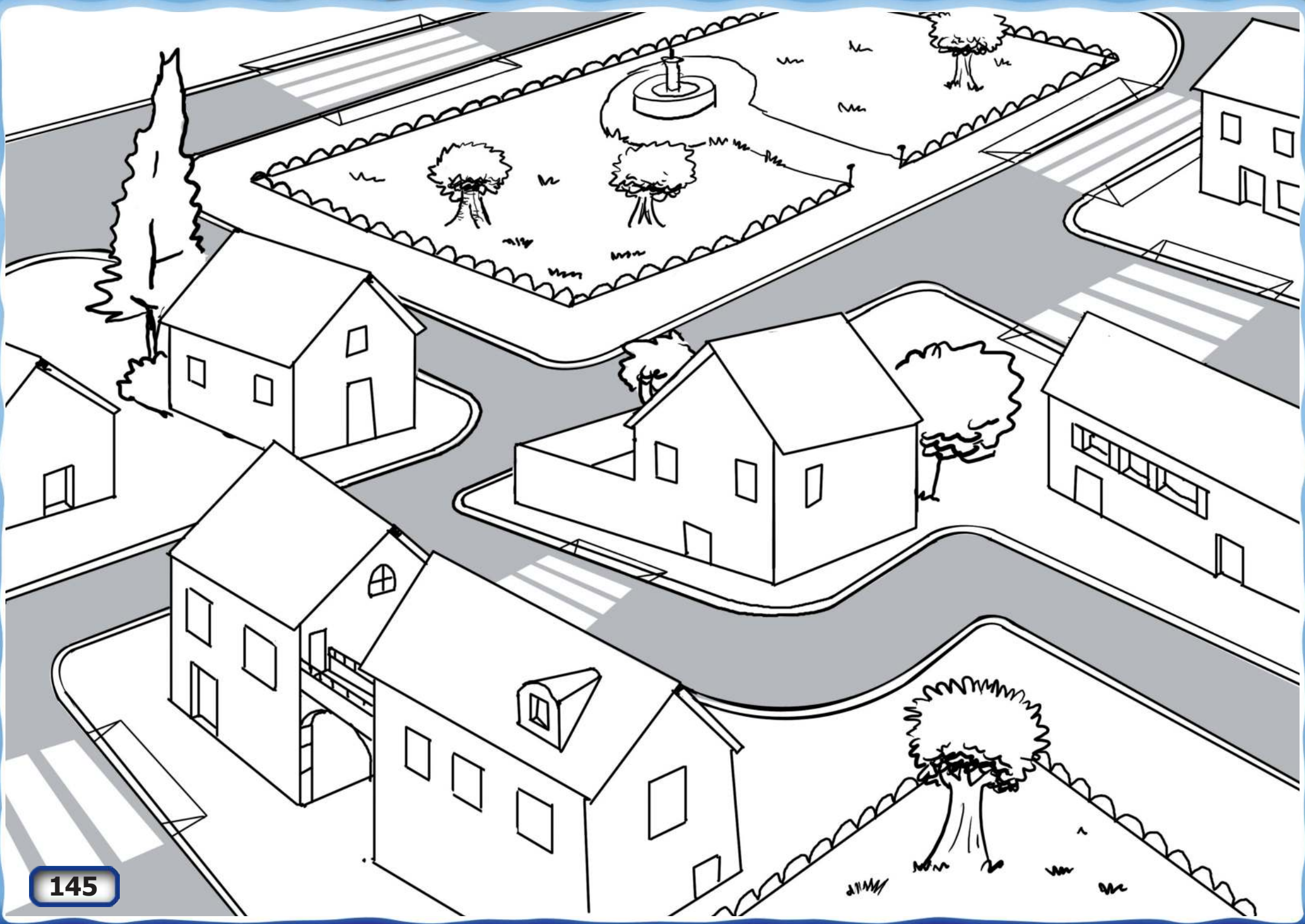



¿Qué dice?

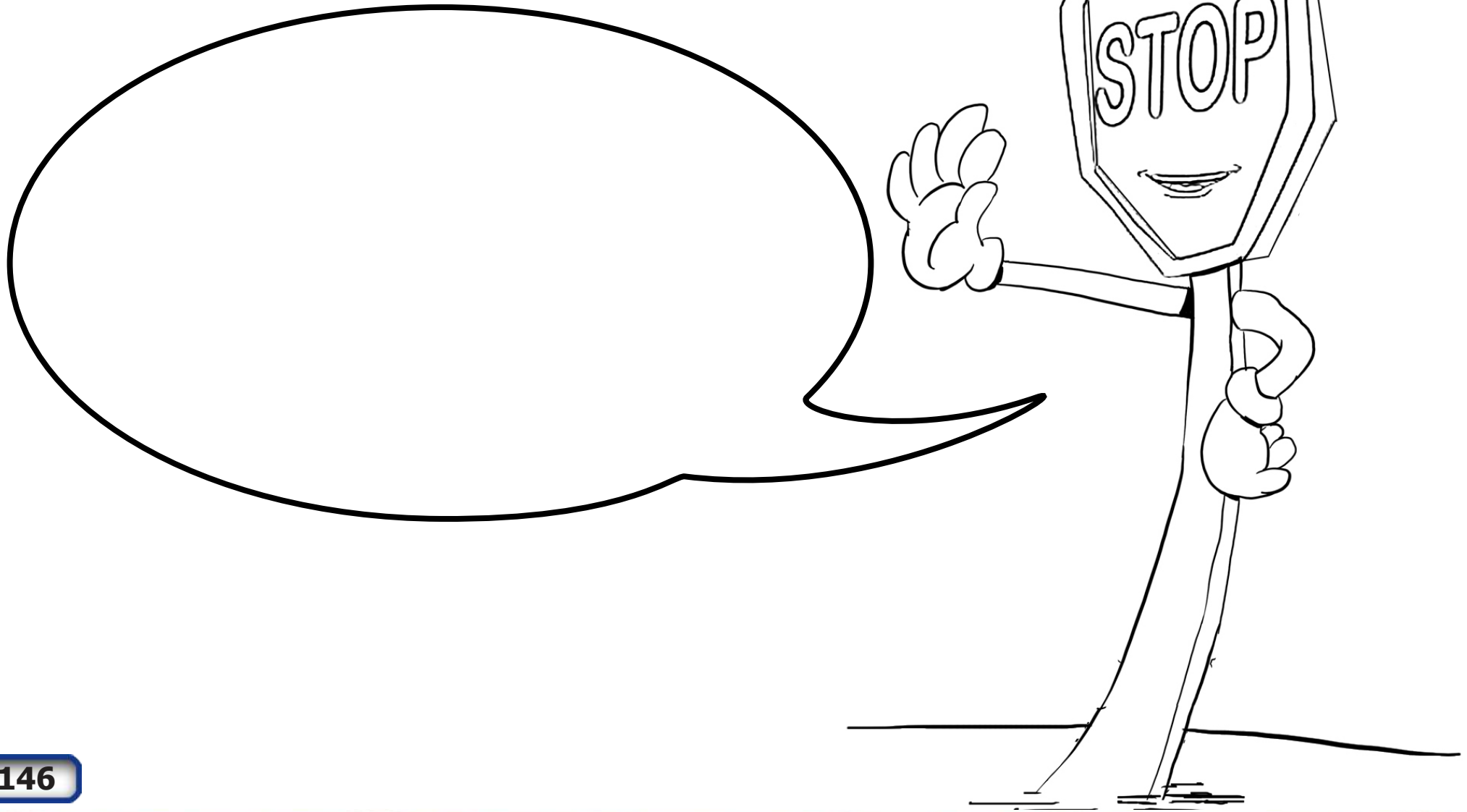

★ ¿Qué dice?

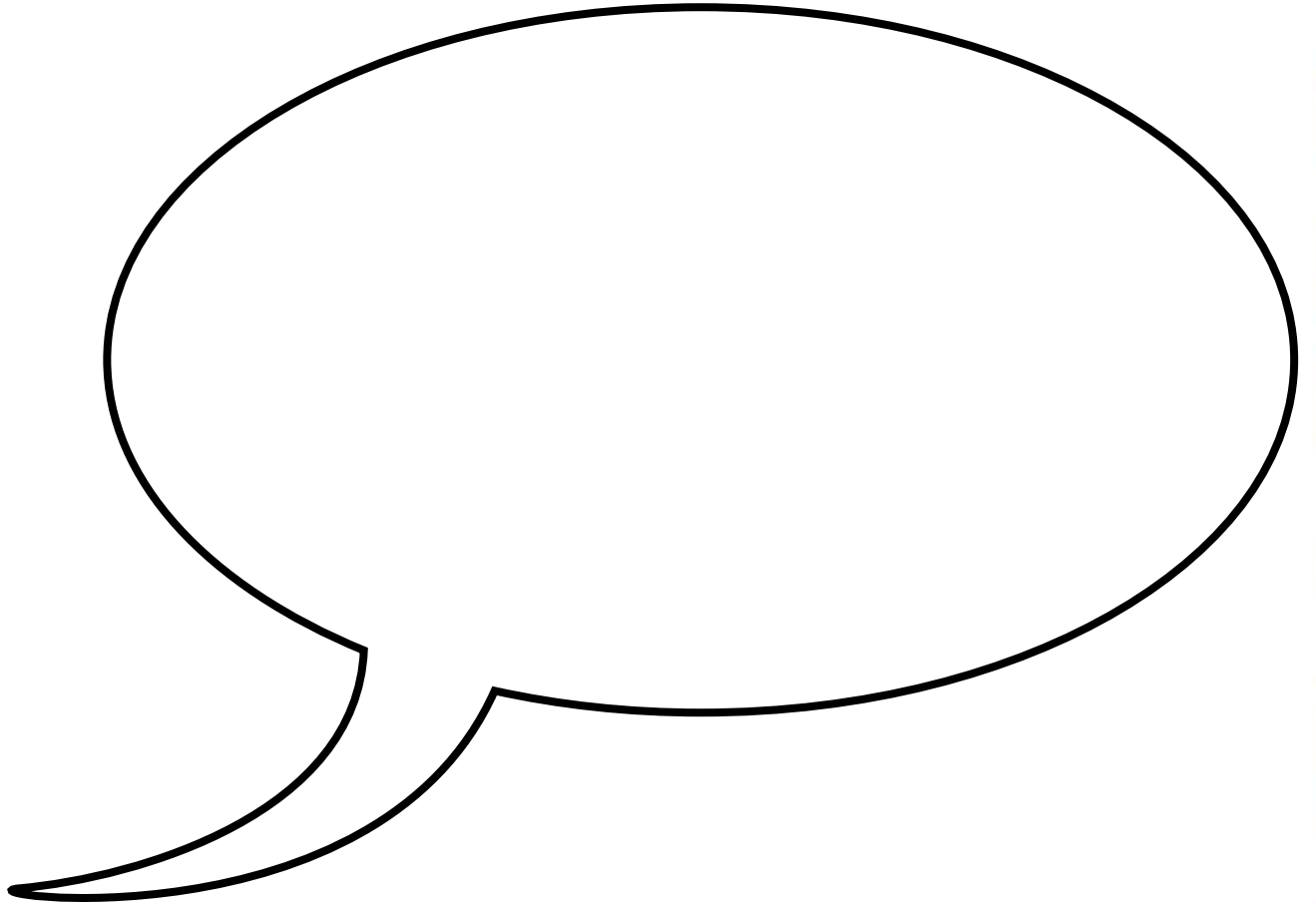
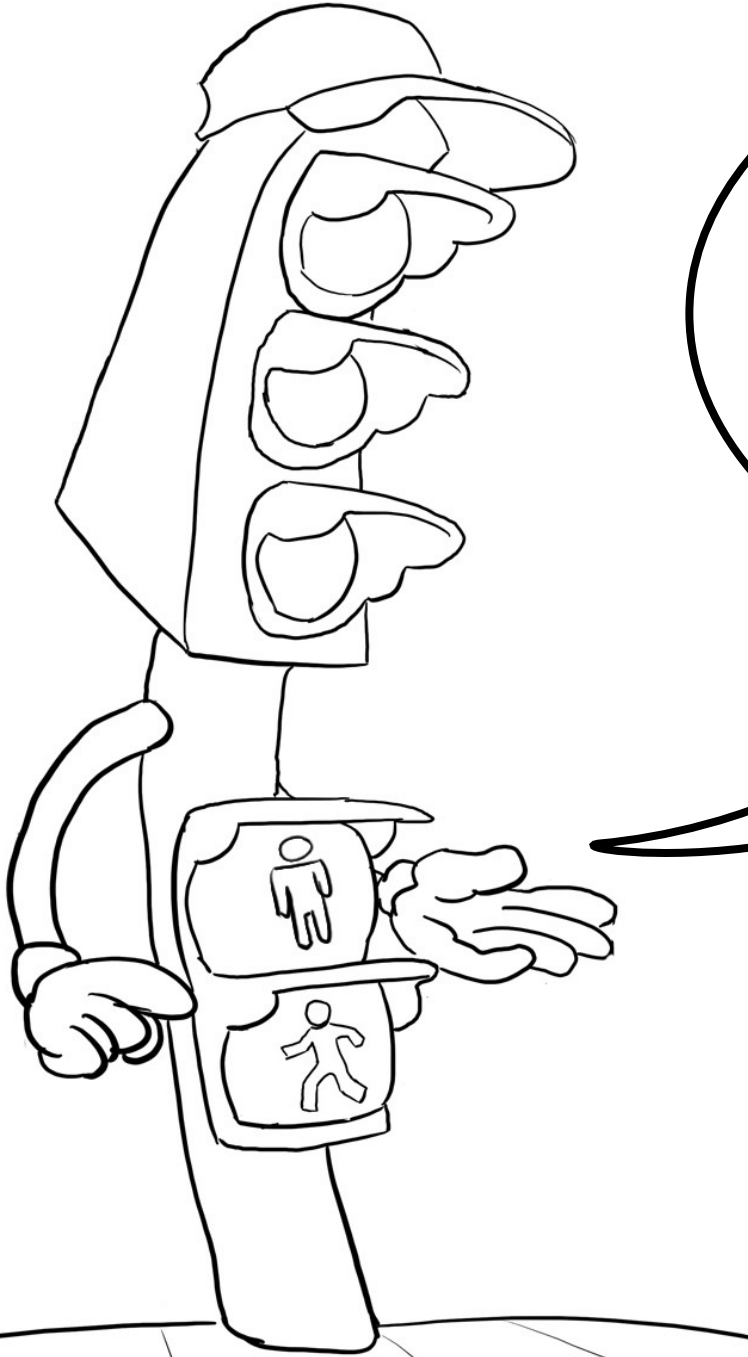

★ ¿Qué dice?

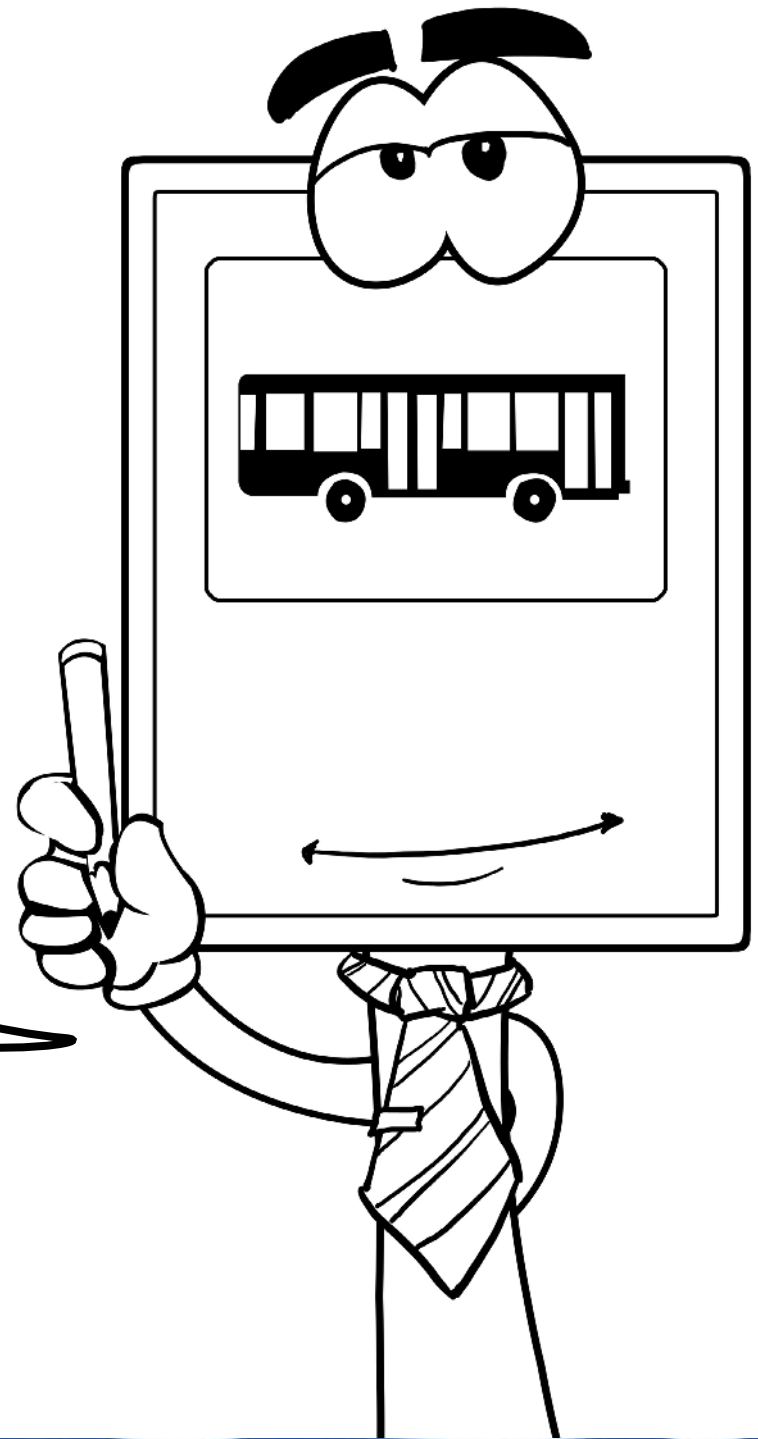
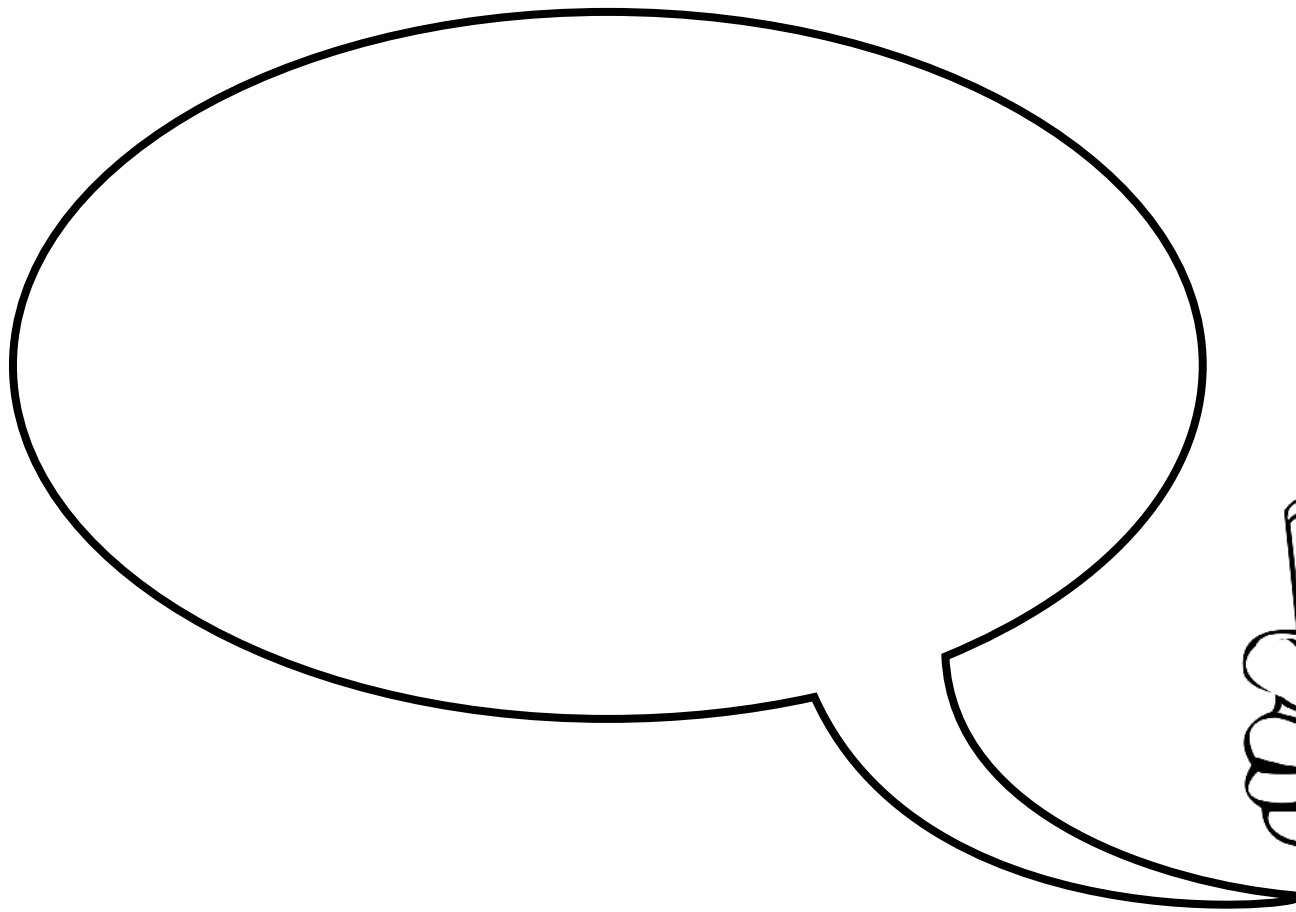

★ ¿Qué dice?

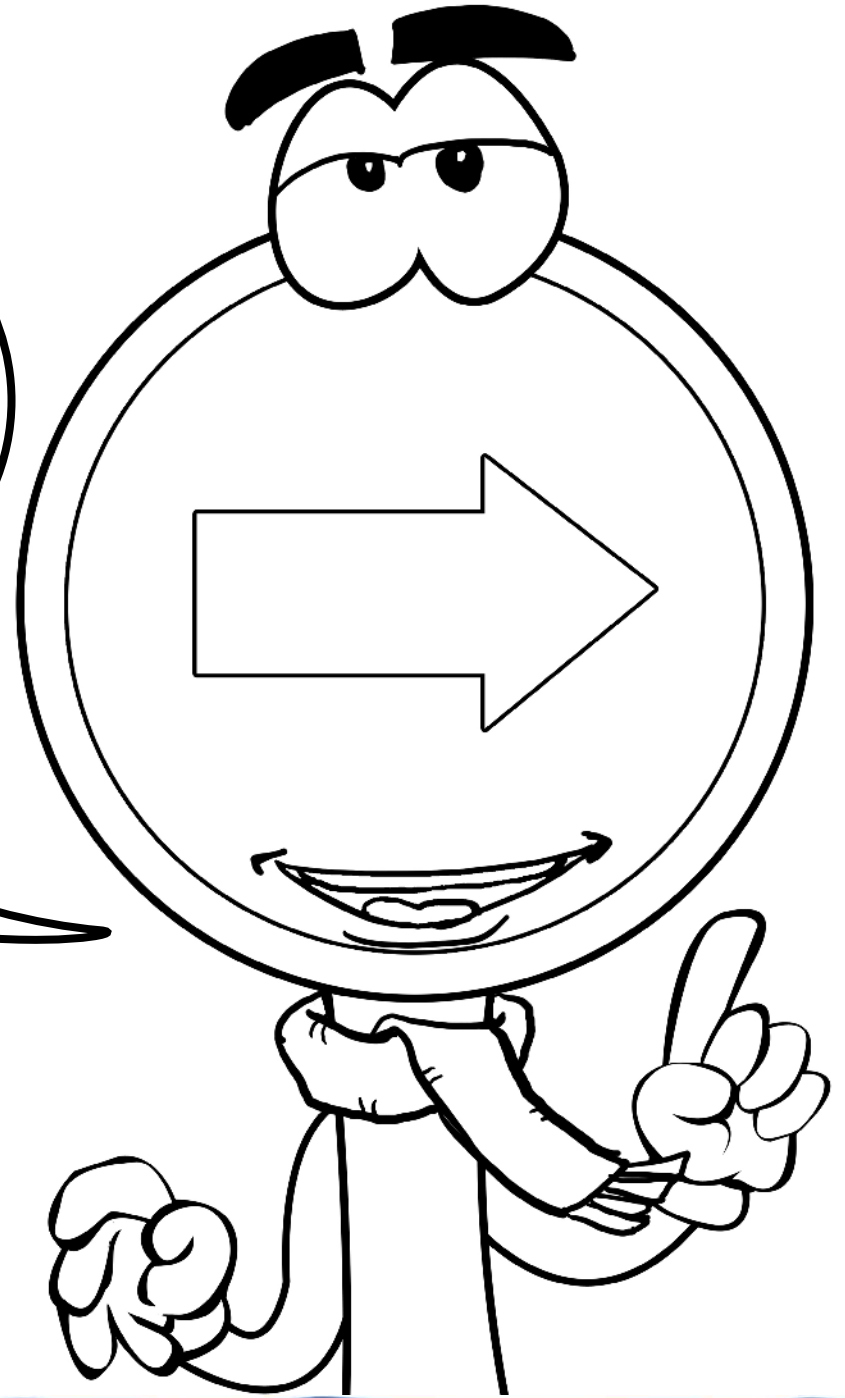
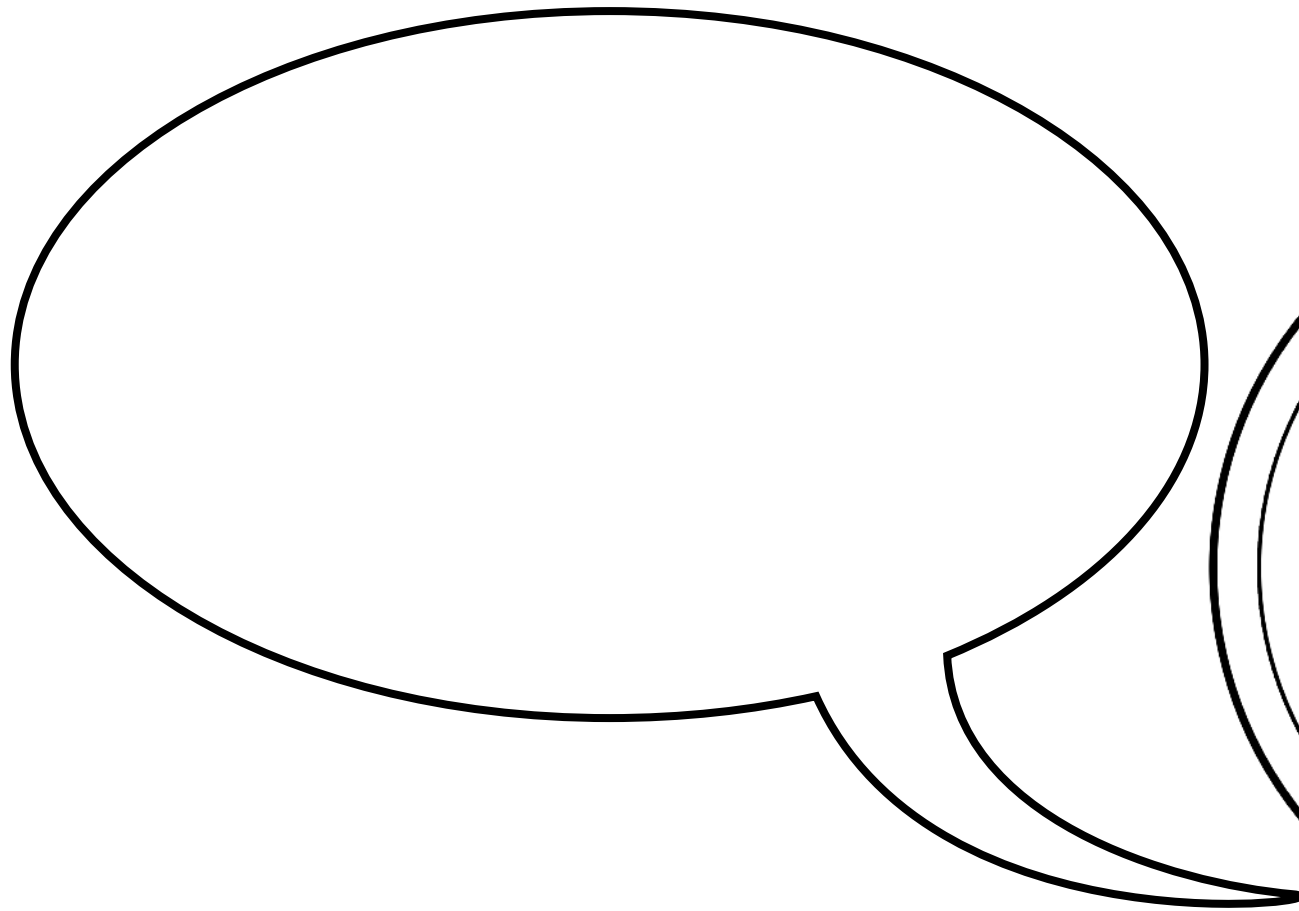

★ ¿Qué dice?

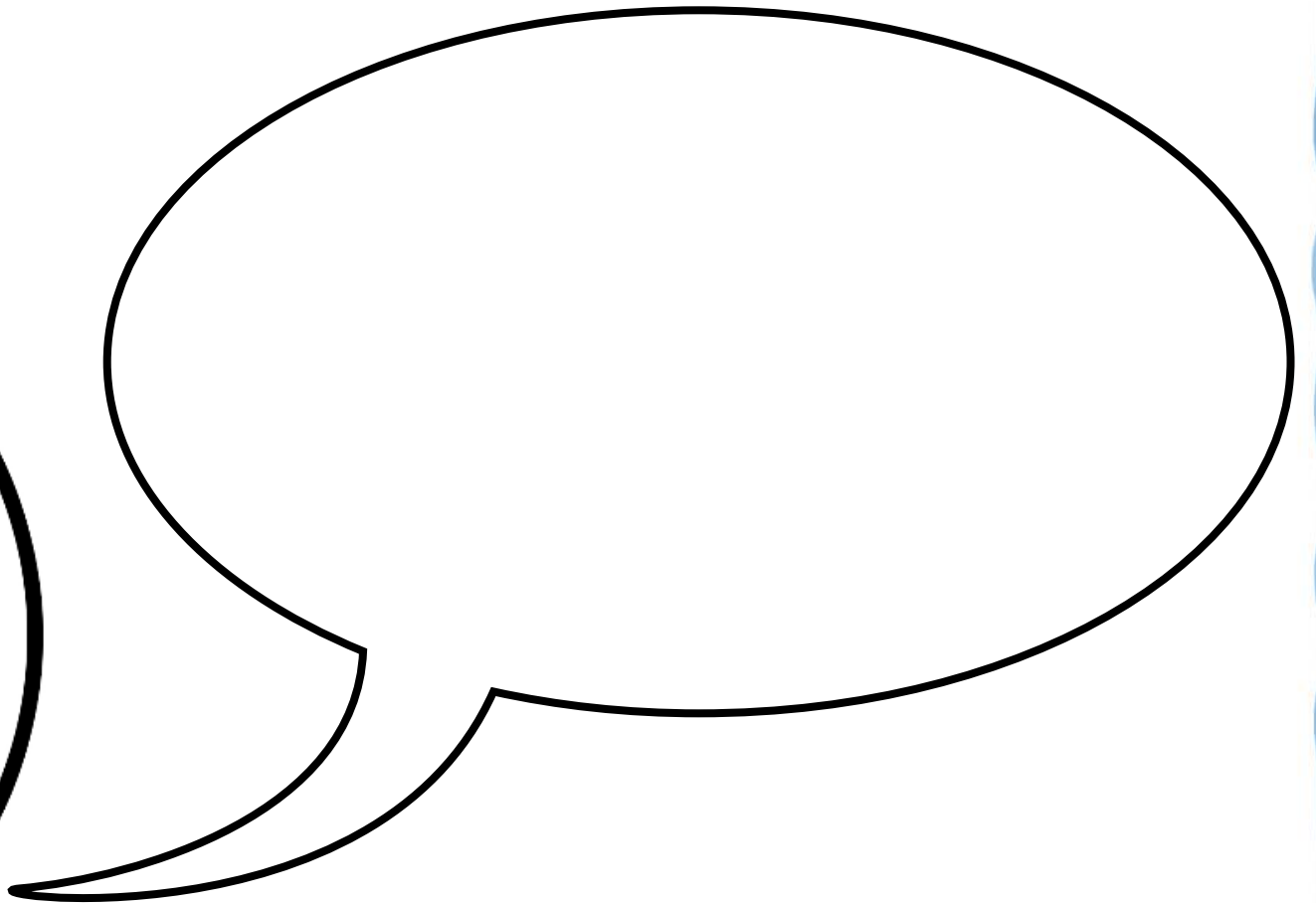
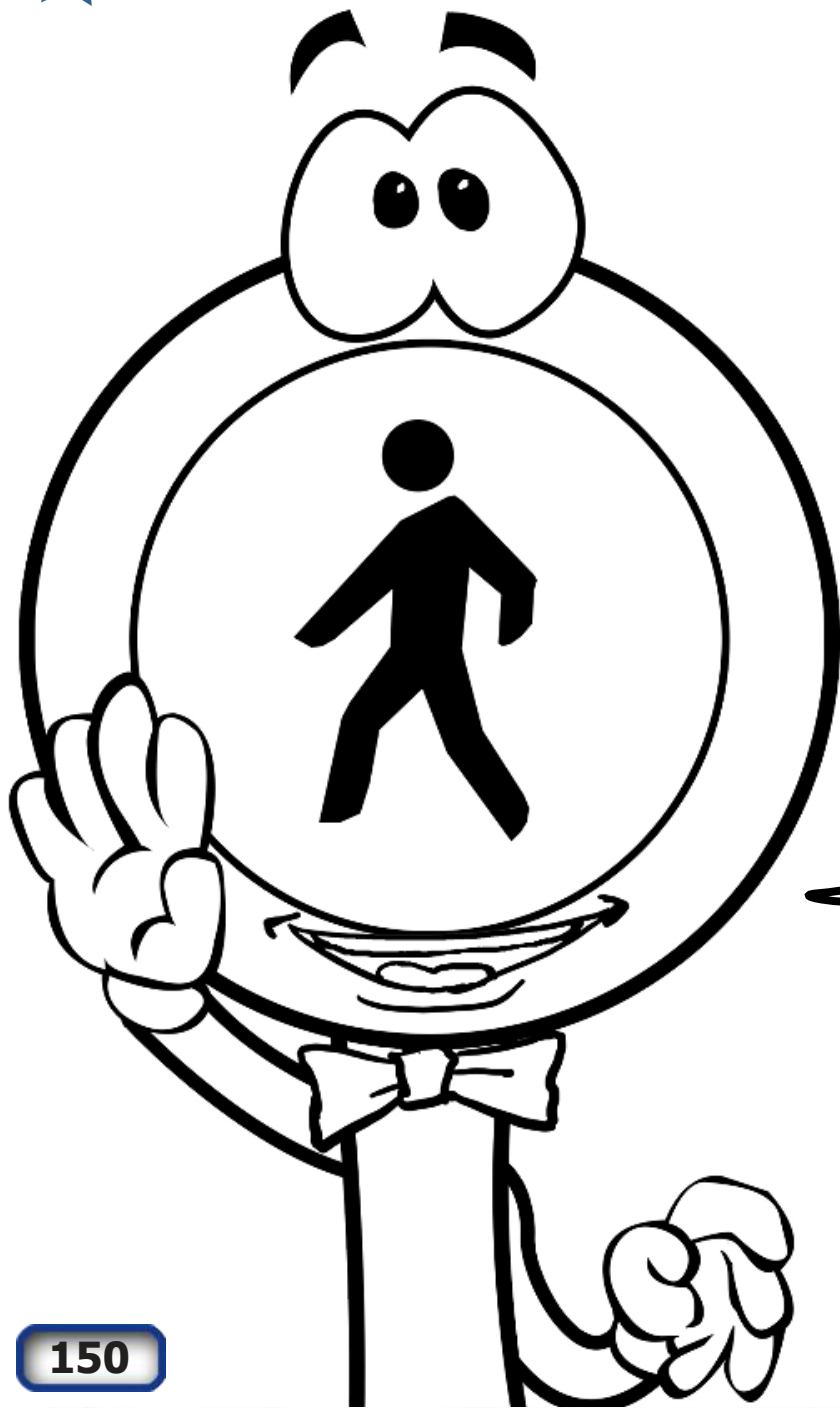

★ ¿Qué piensa?

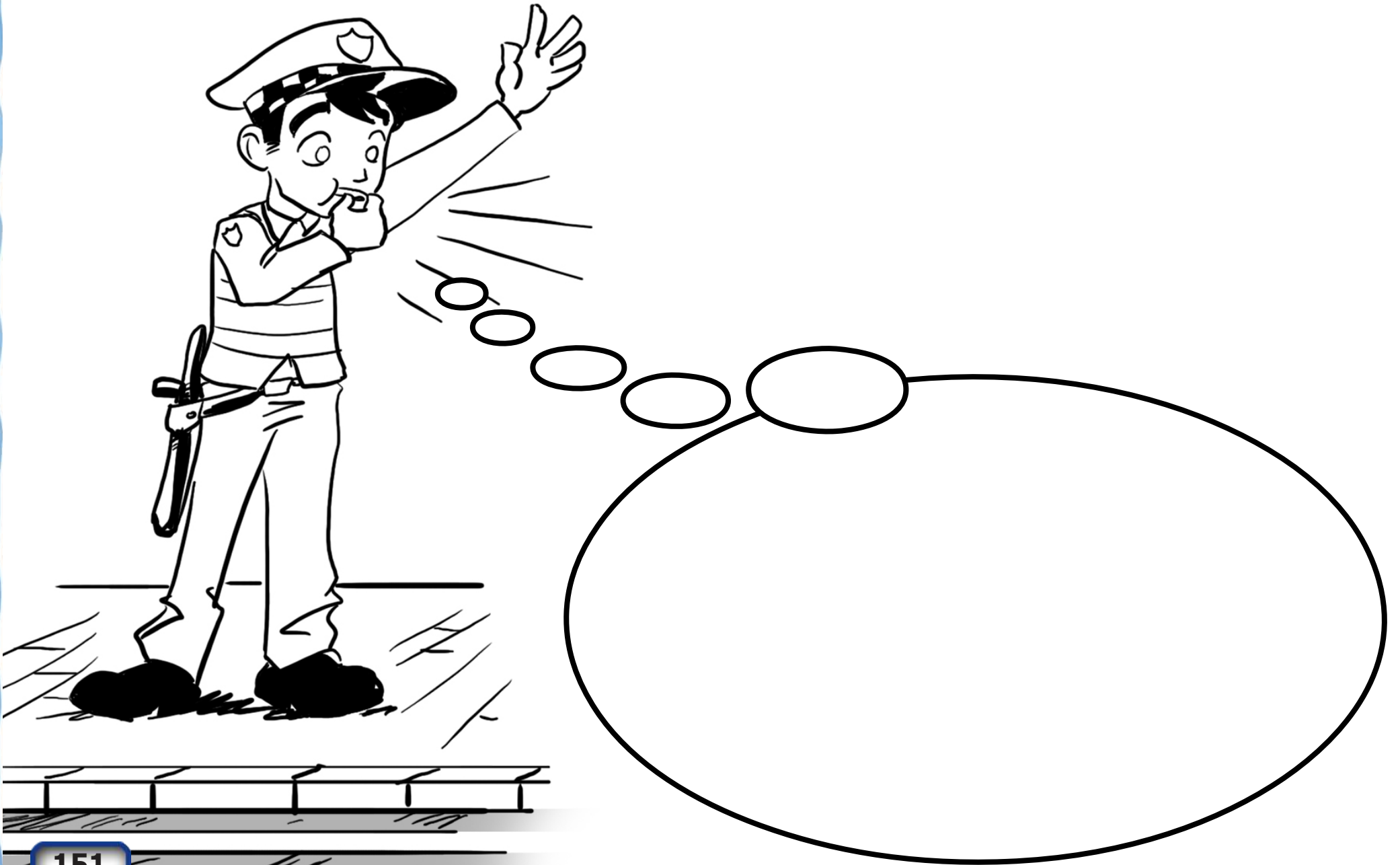

★ ¿Qué piensa?

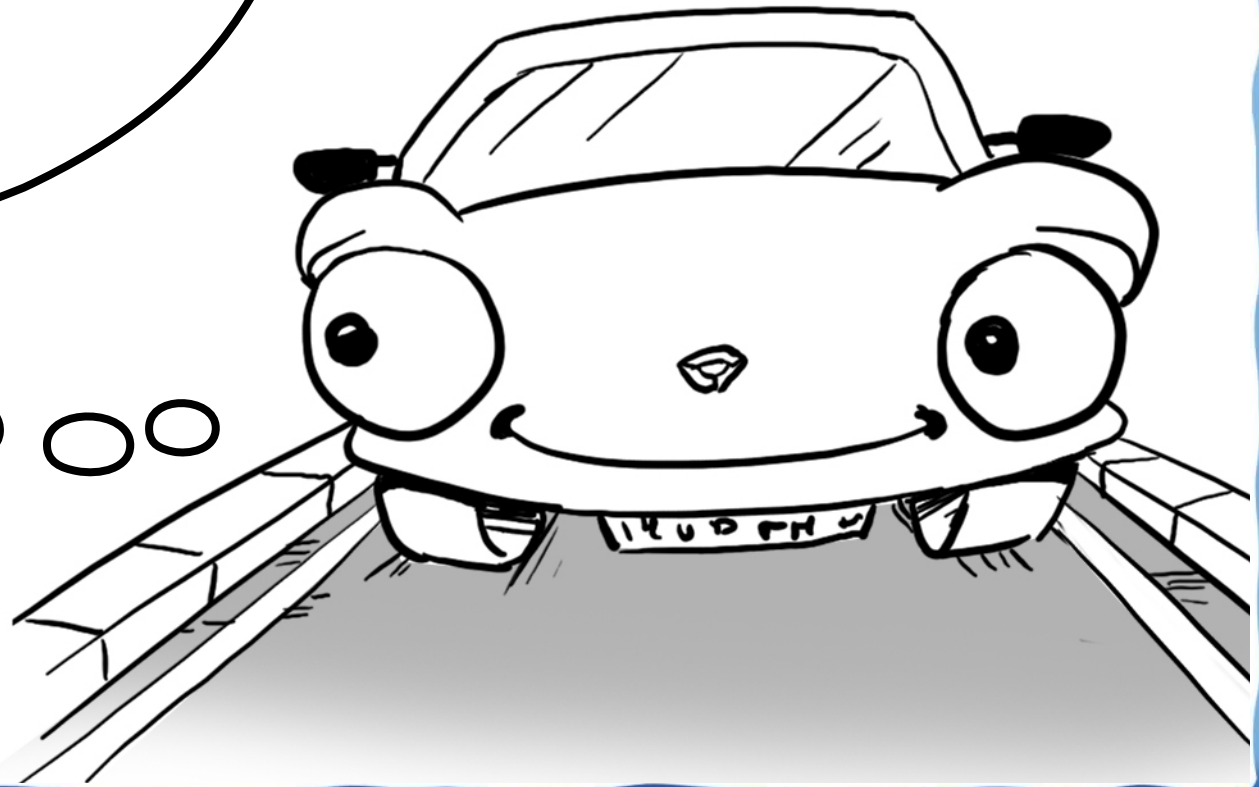
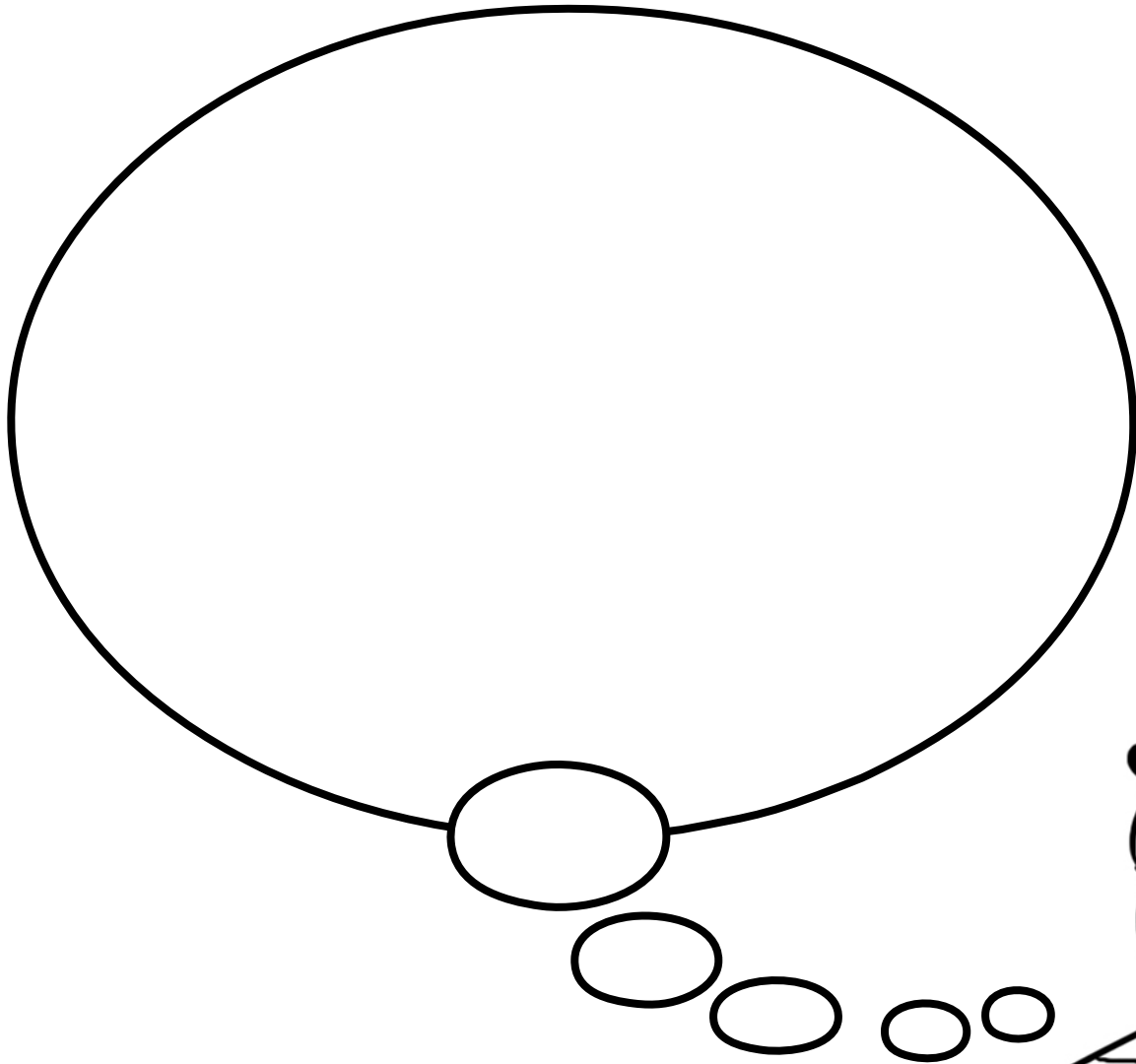



★ ¿Qué dicen?

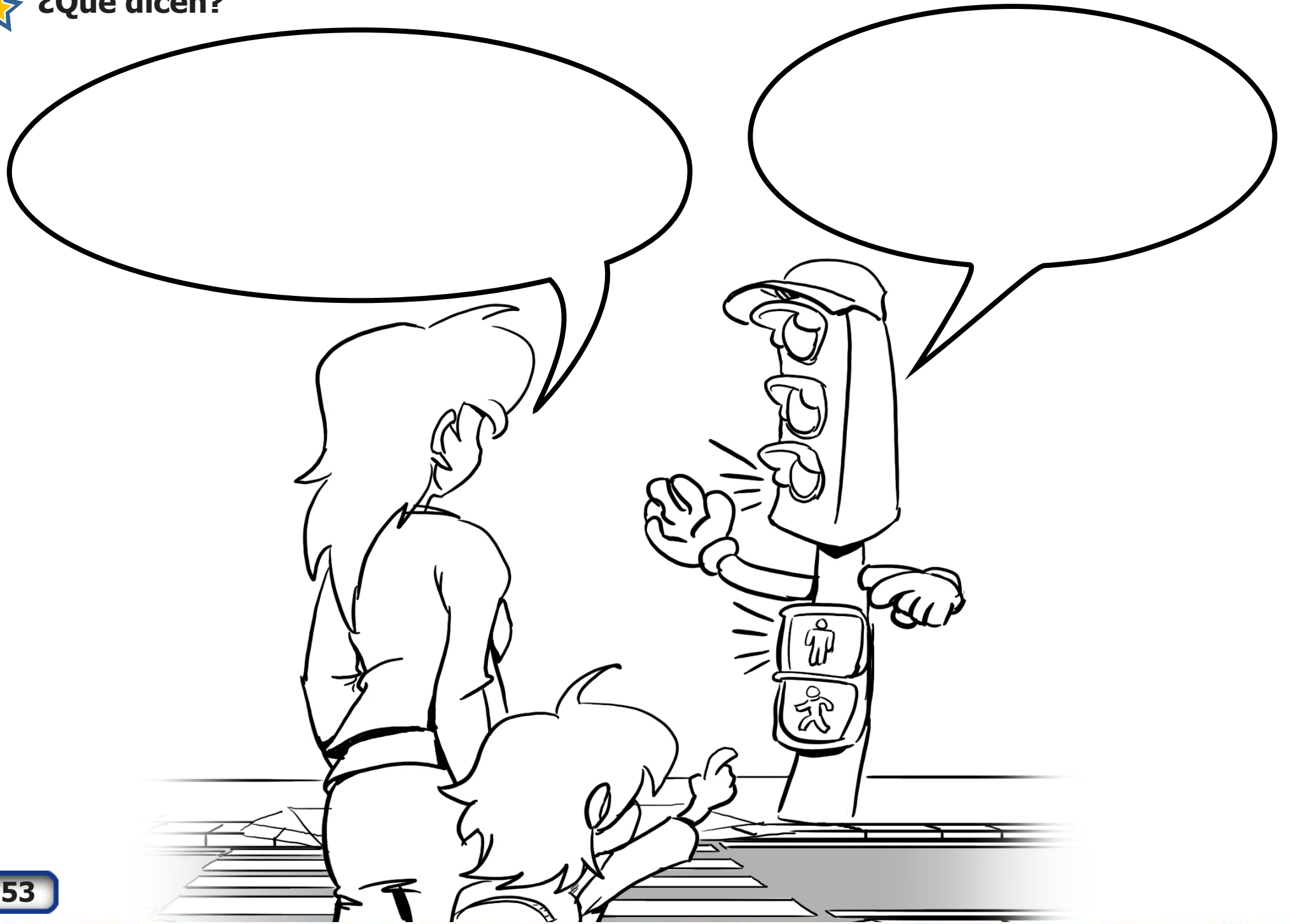

★ ¿Qué dicen?

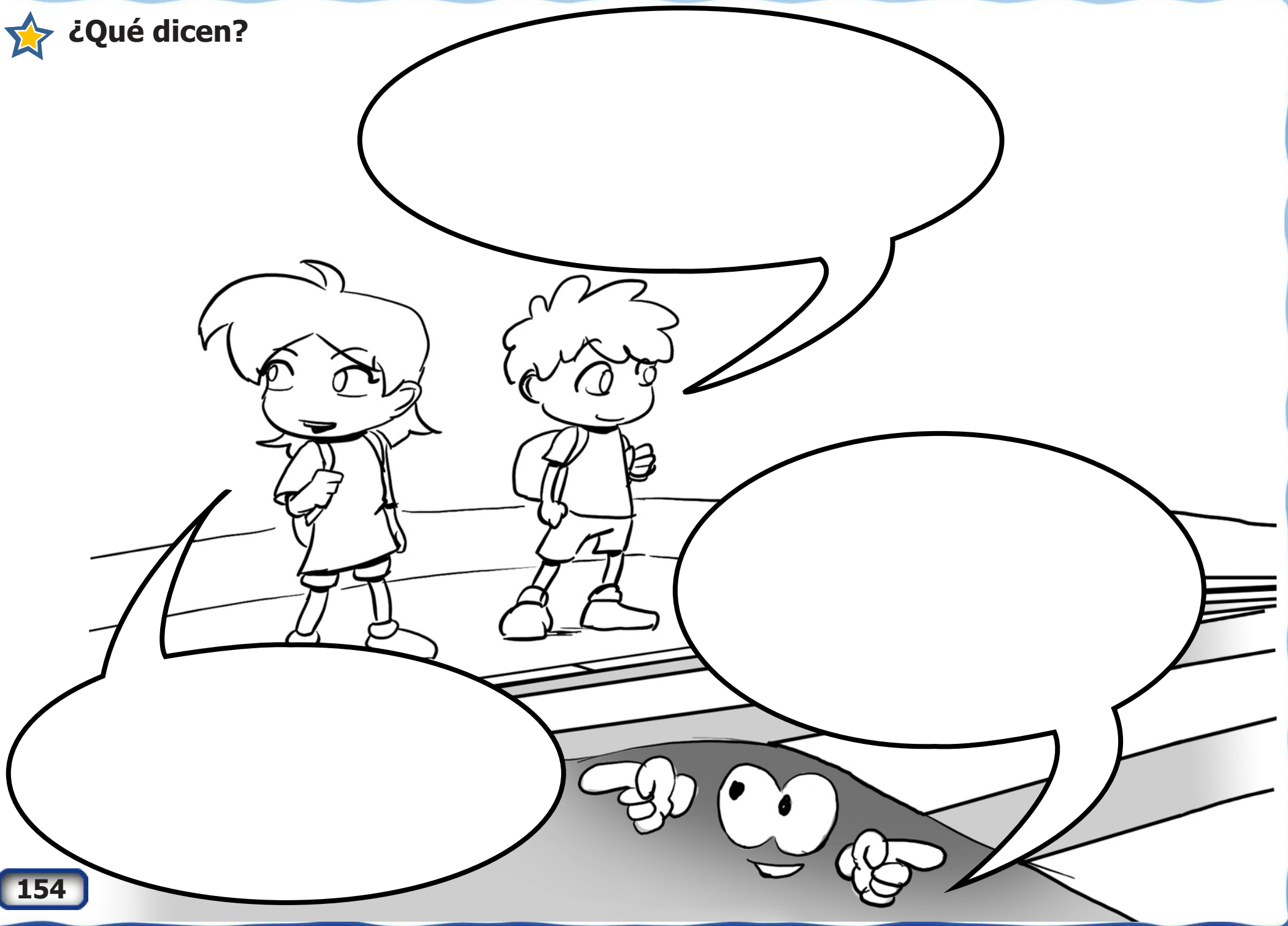

★ Escribe en cada recuadro el nombre que corresponda.

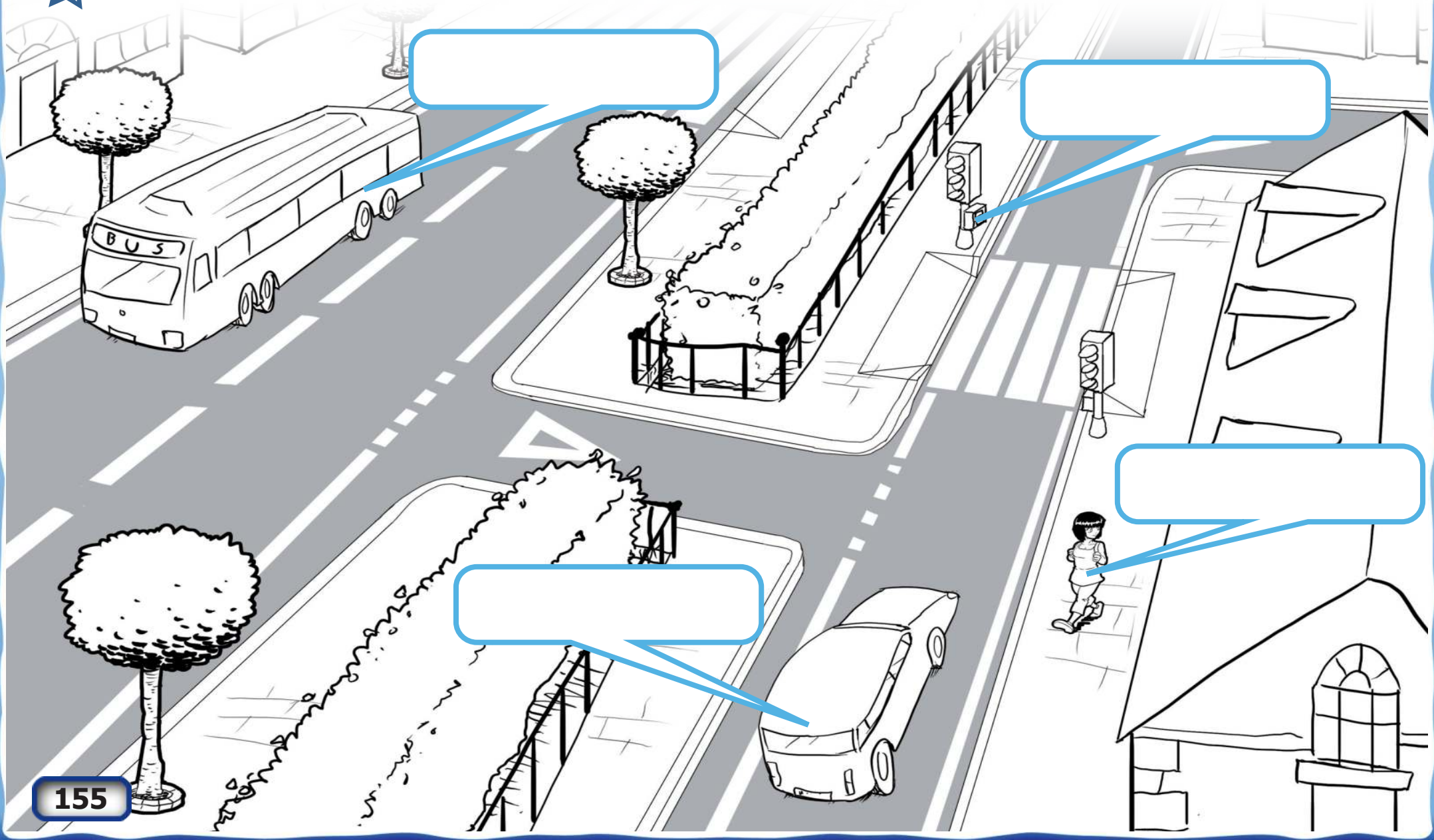



Escribe en cada recuadro el nombre que corresponda.

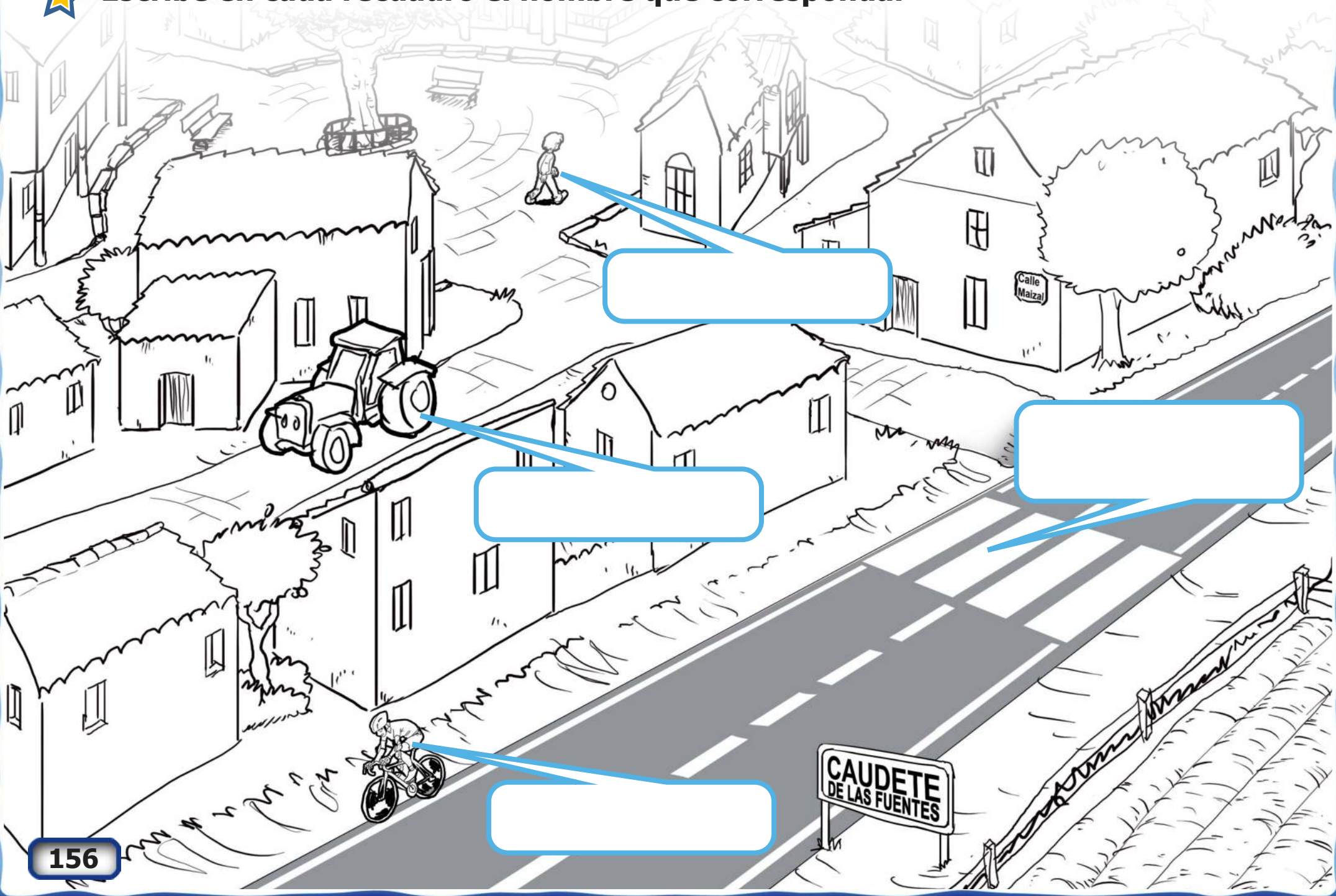

★ Señala quién circula bien y quién circula mal.



Bien  Mal

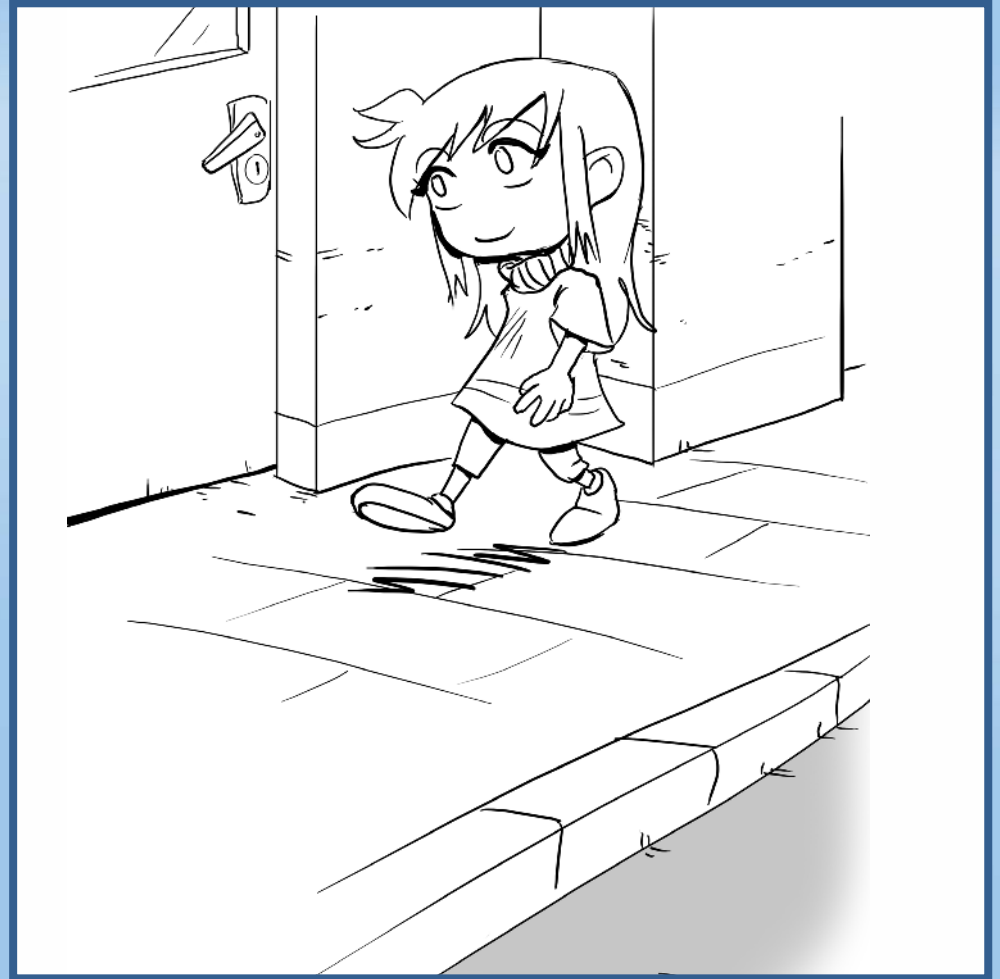

Bien  Mal



Bien     Mal

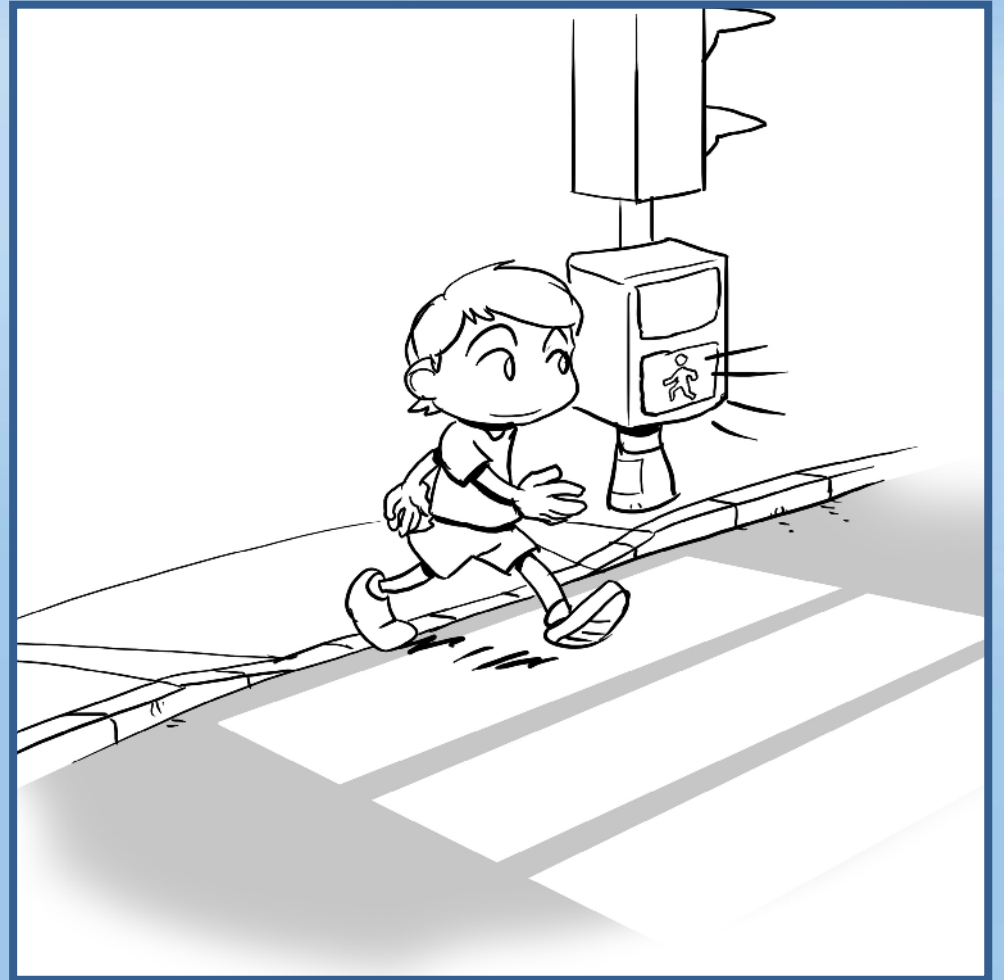

Bien     Mal



Medios de transporte.

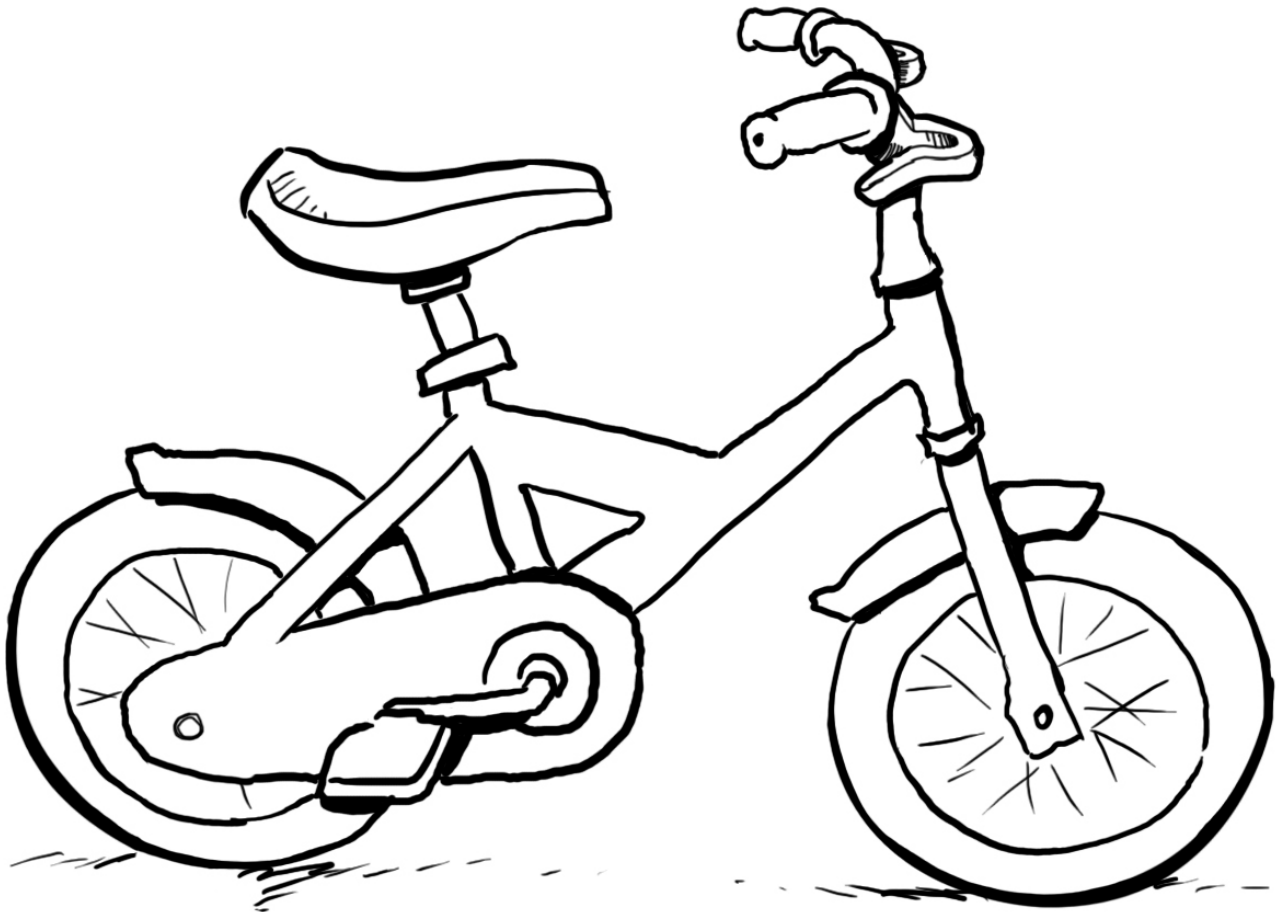

Bicicleta

**BICICLETA**

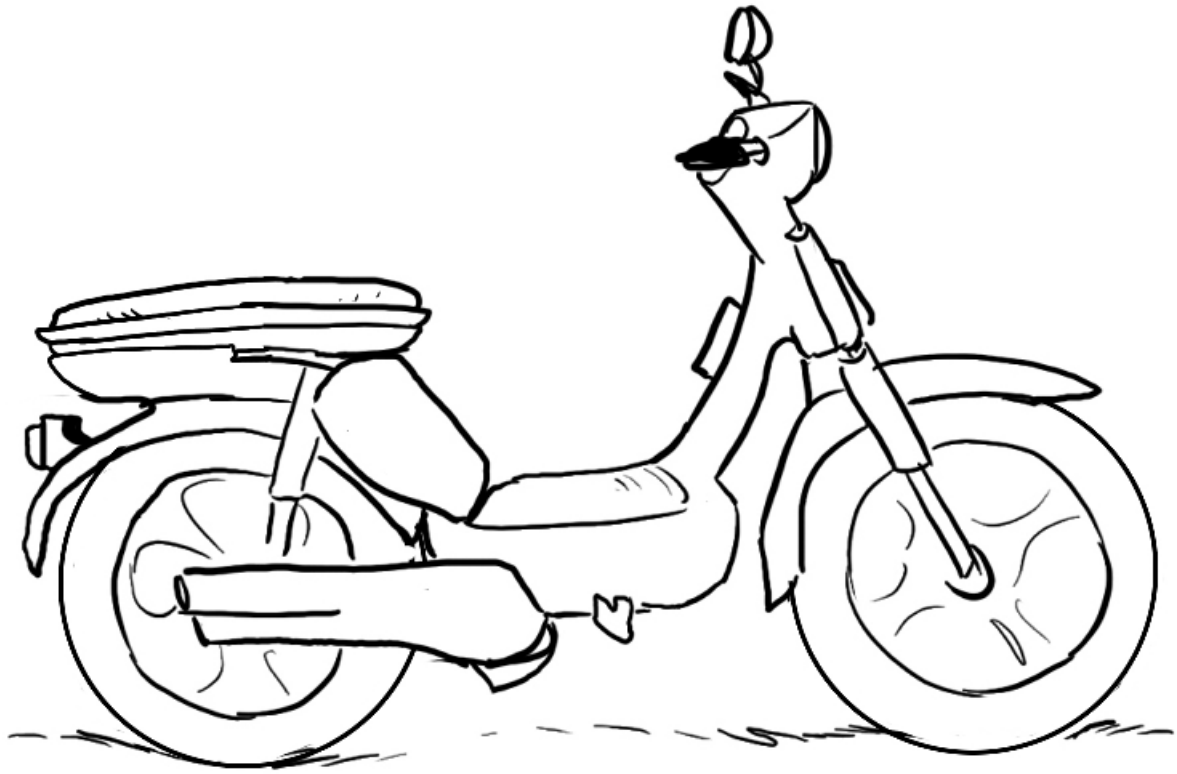

*Ciclomotor*  
**CICLOMOTOR**



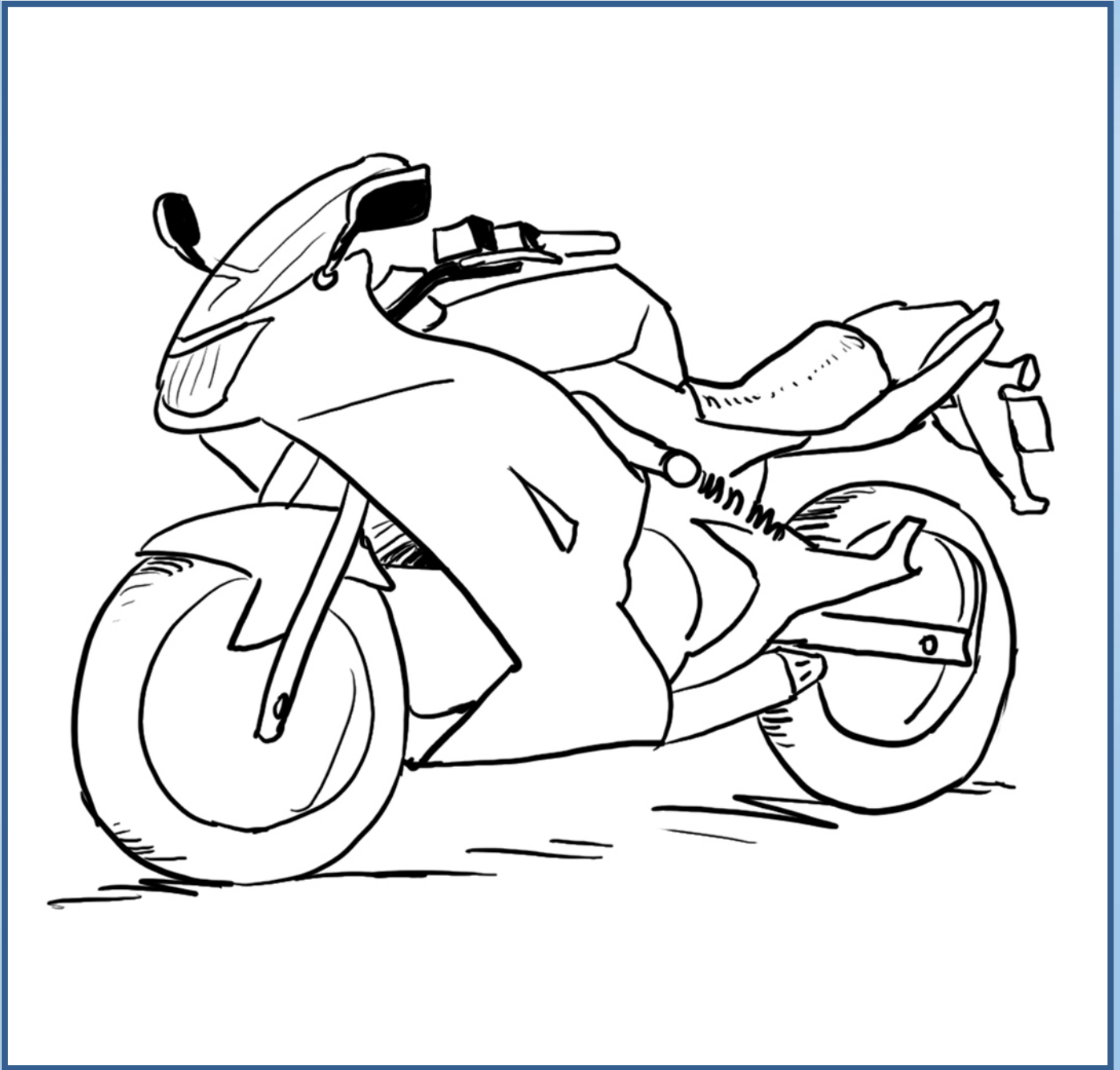

Motocicleta  
**MOTOCICLETA**

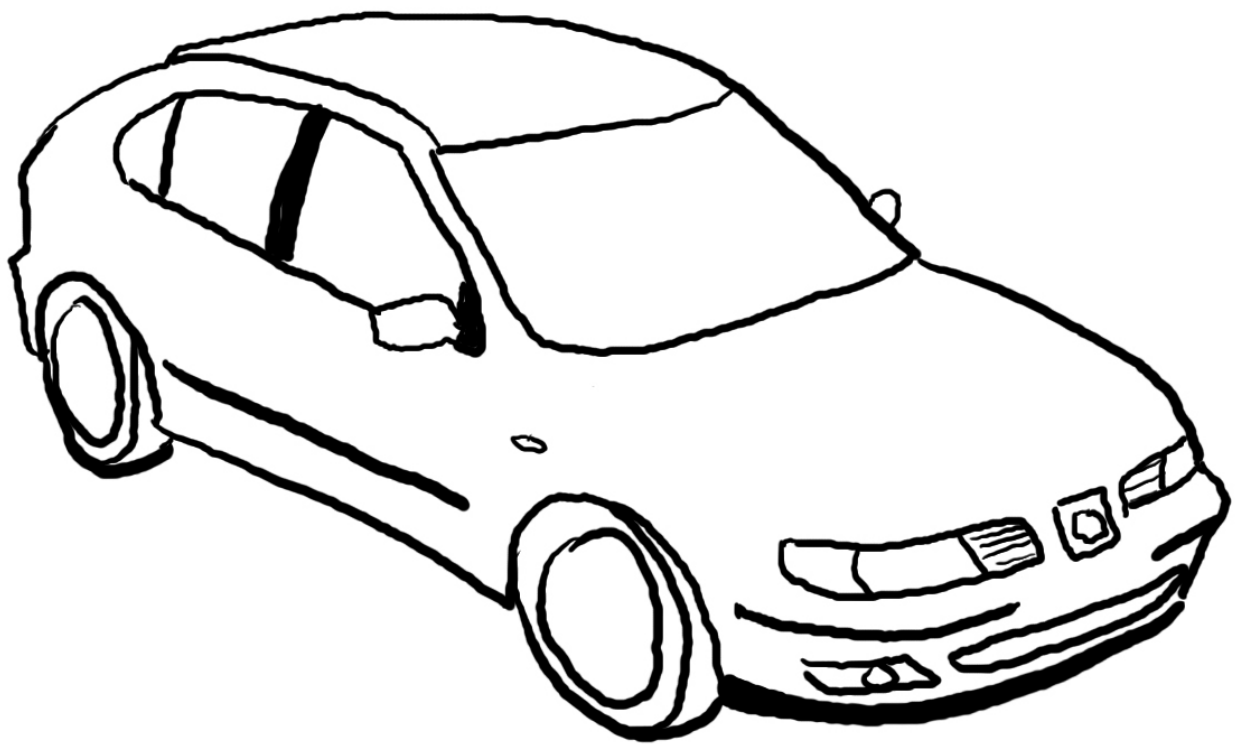

Coche

**COCHE**

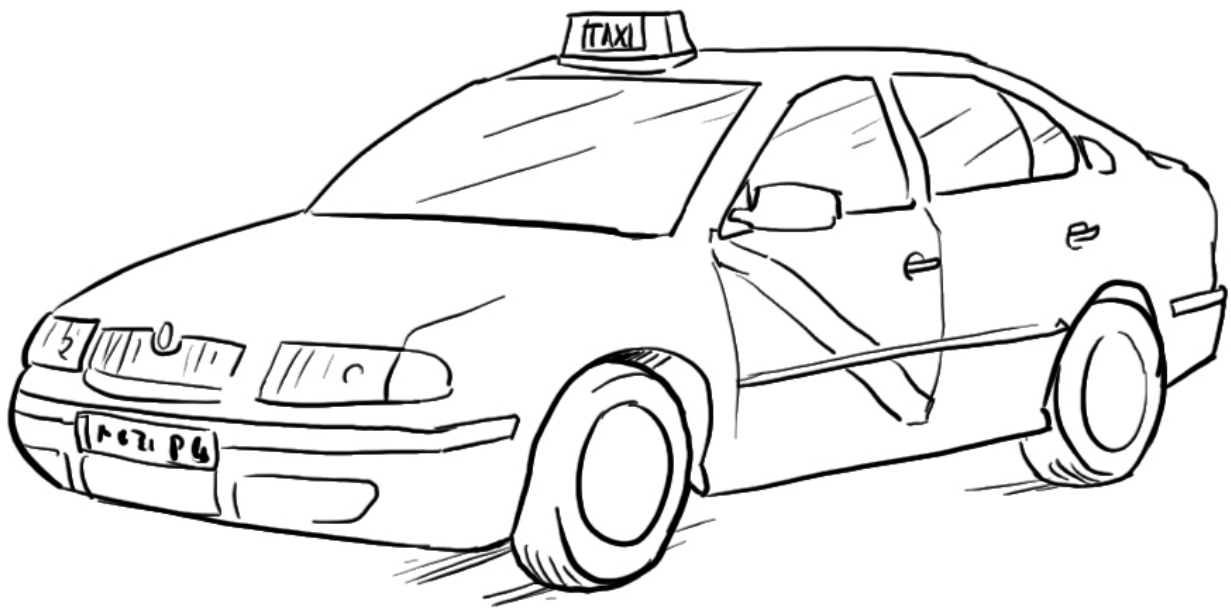

Taxi

**TAXI**

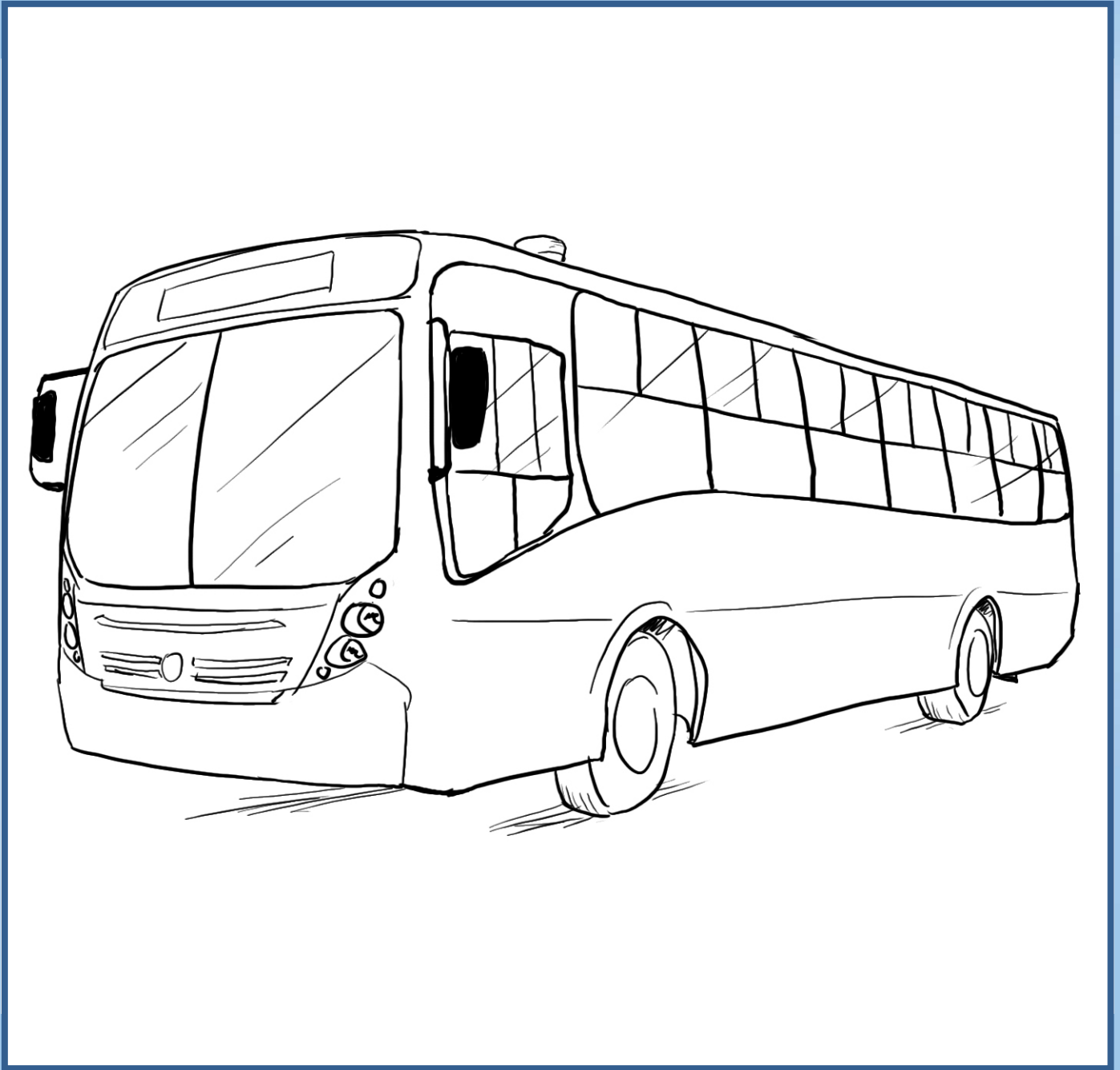

*Autobús*  
**AUTOBÚS**

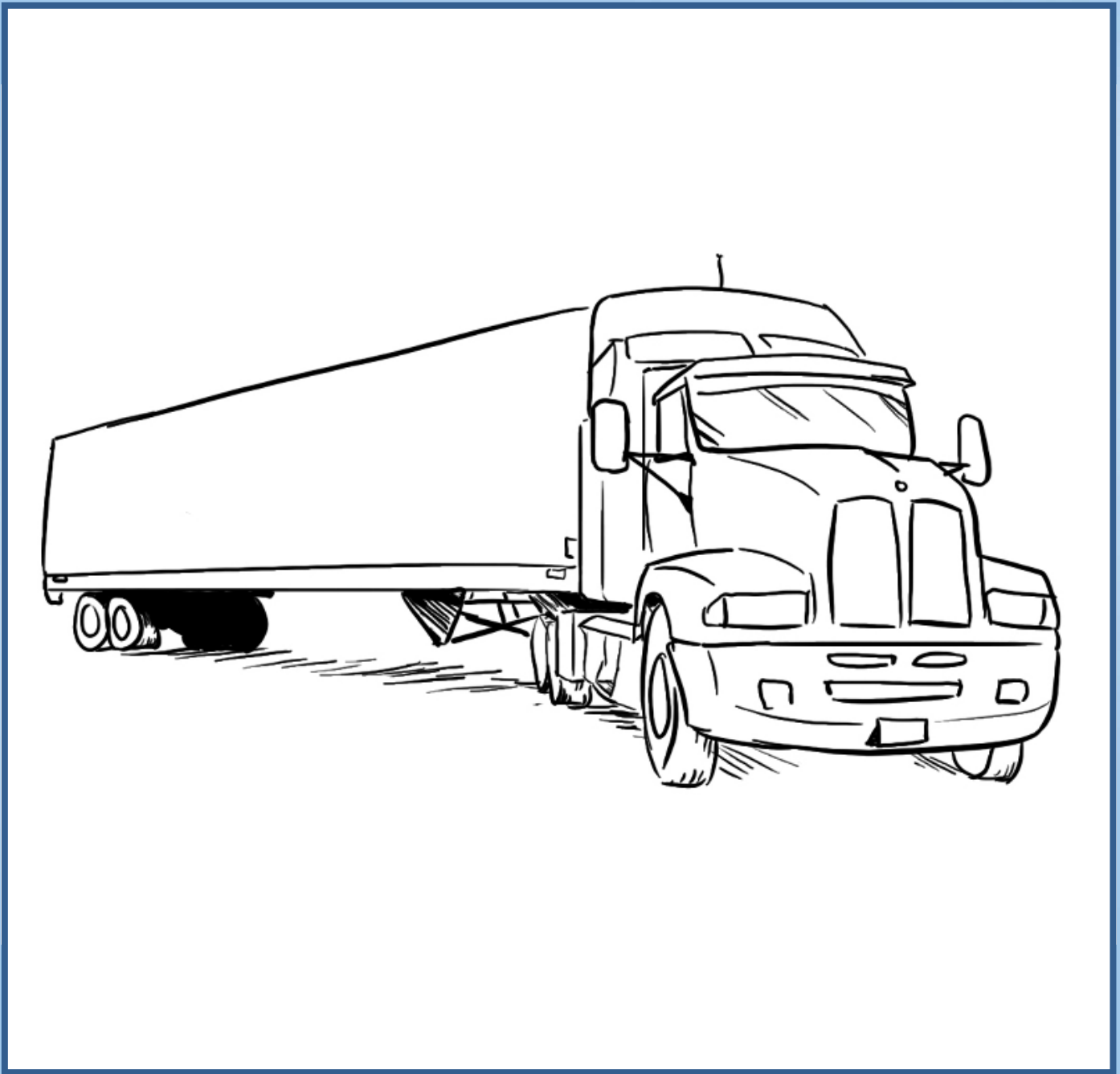

Camión  
**CAMIÓN**



Recorta y pega en la siguiente página.

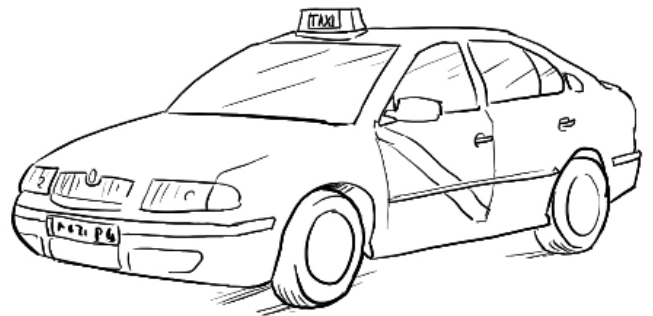
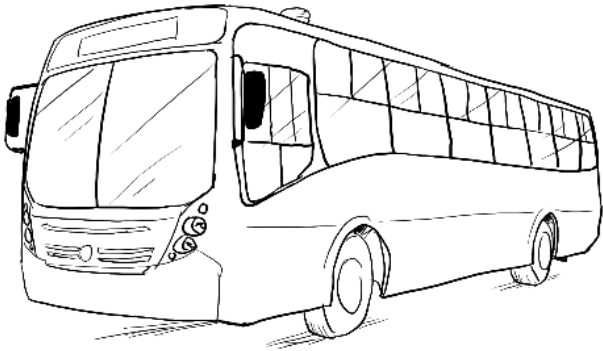
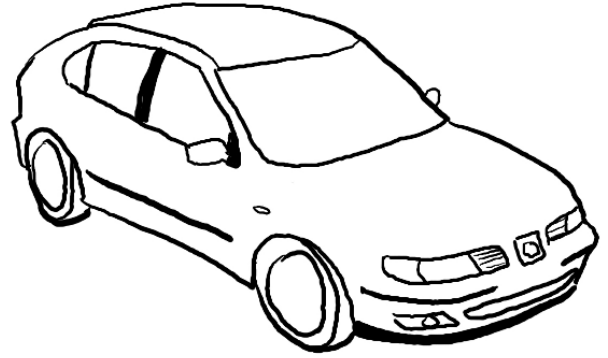
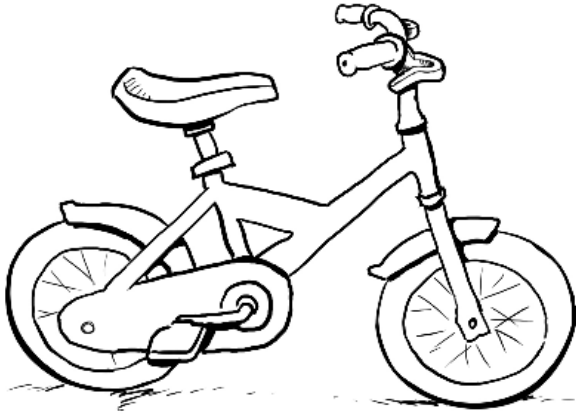

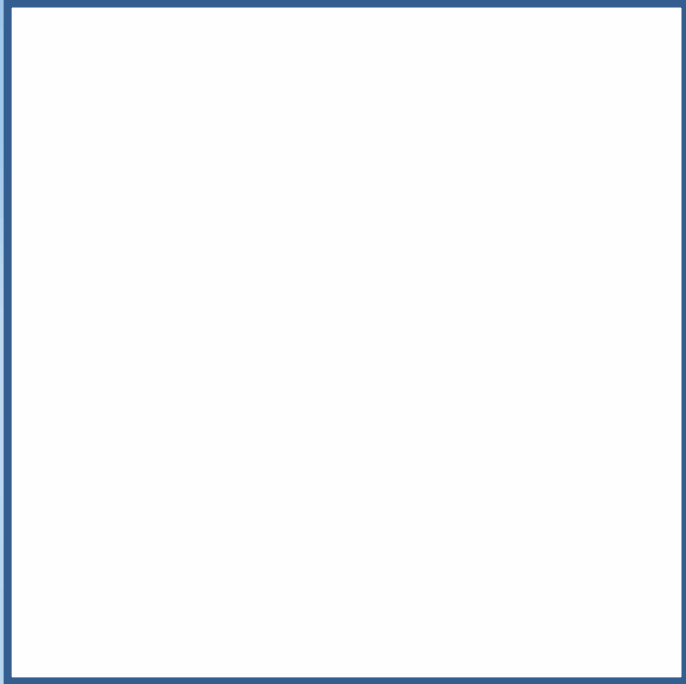

Taxi

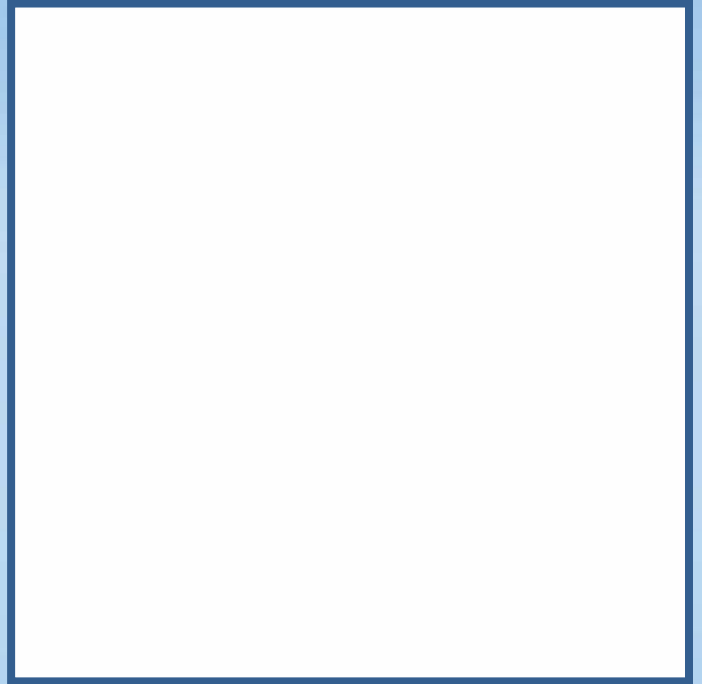

Bicicleta

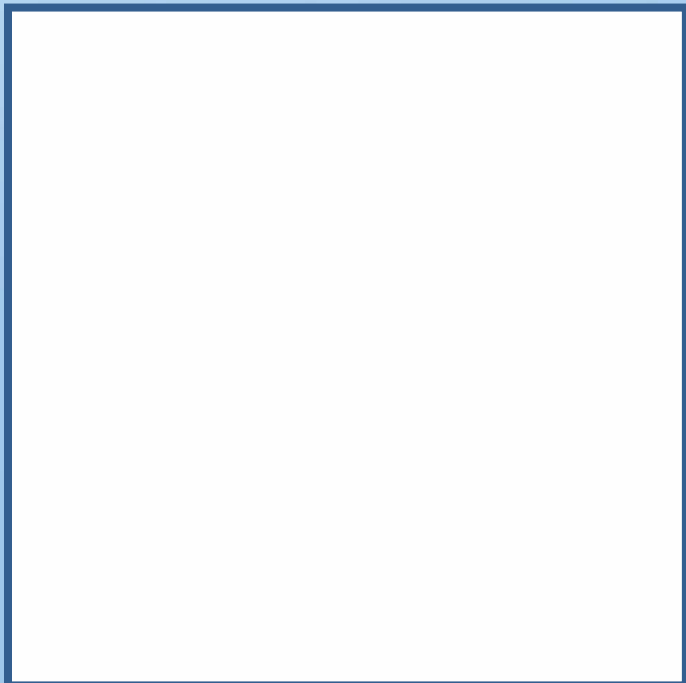

Coche

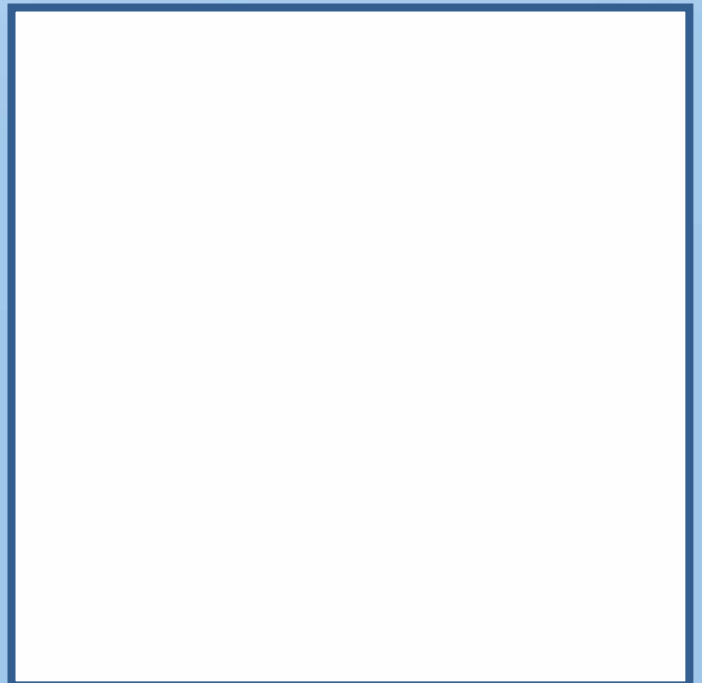

Autobús

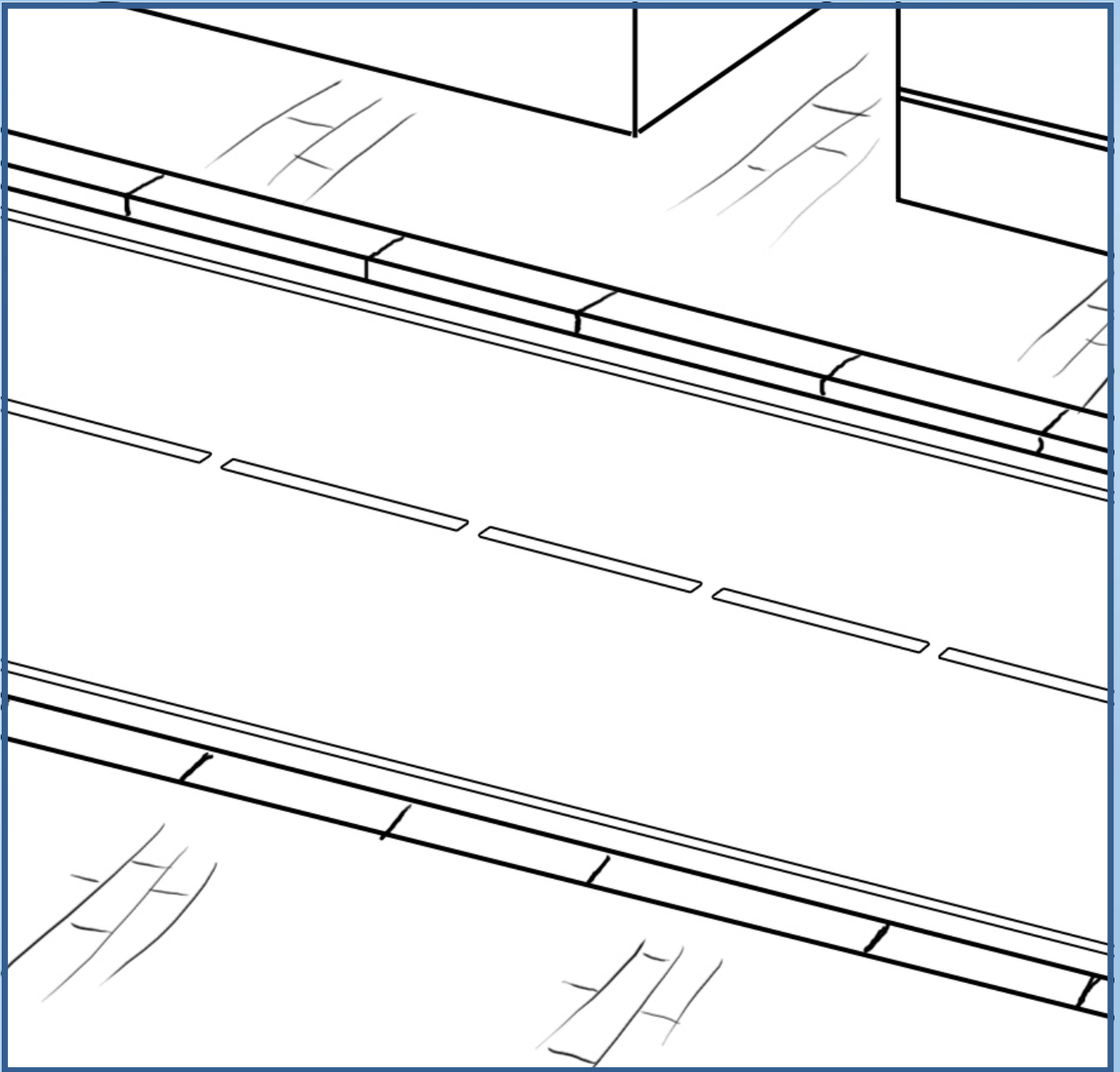

Calzada

**CALZADA**



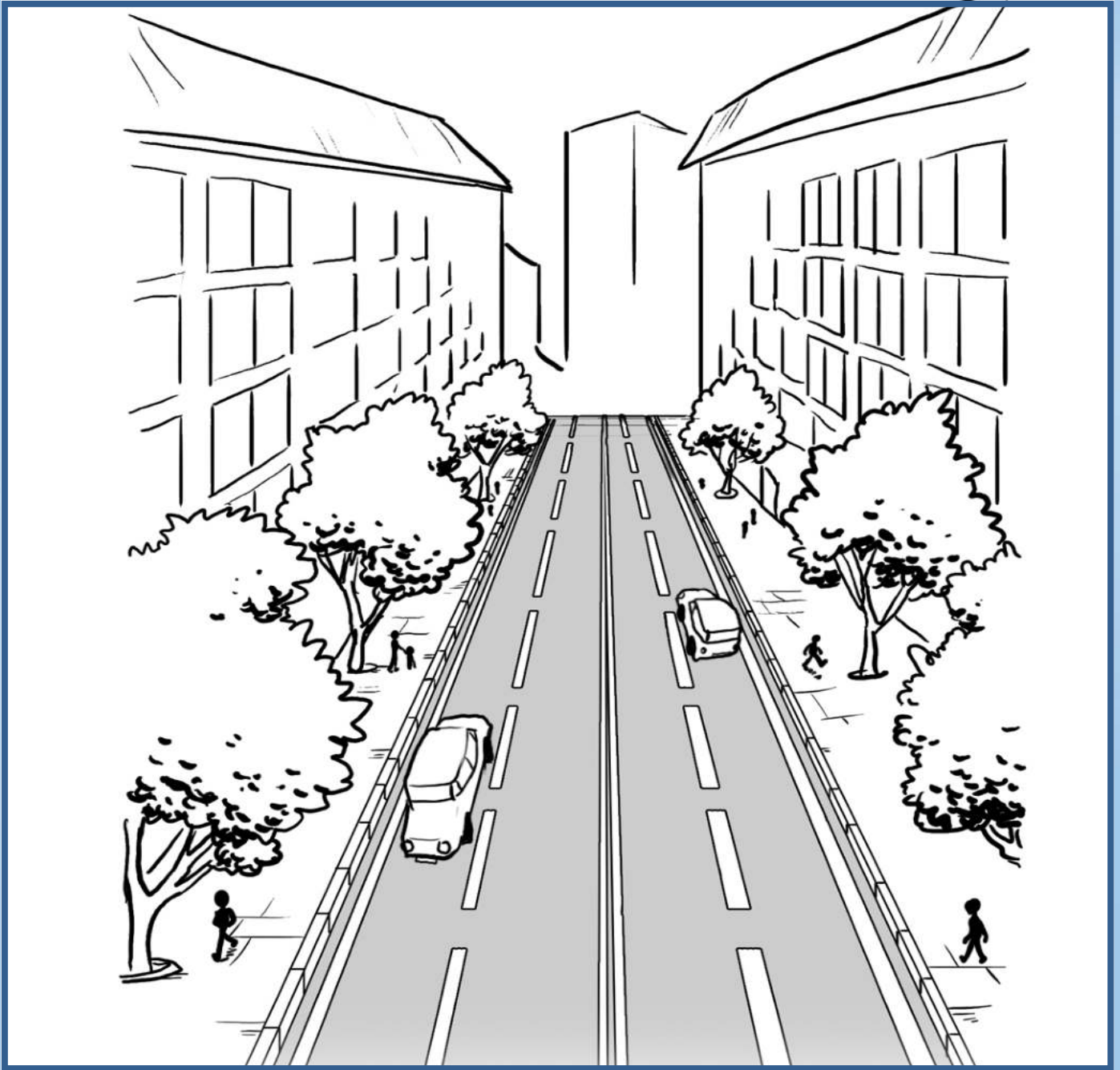

Avenida  
**AVENIDA**

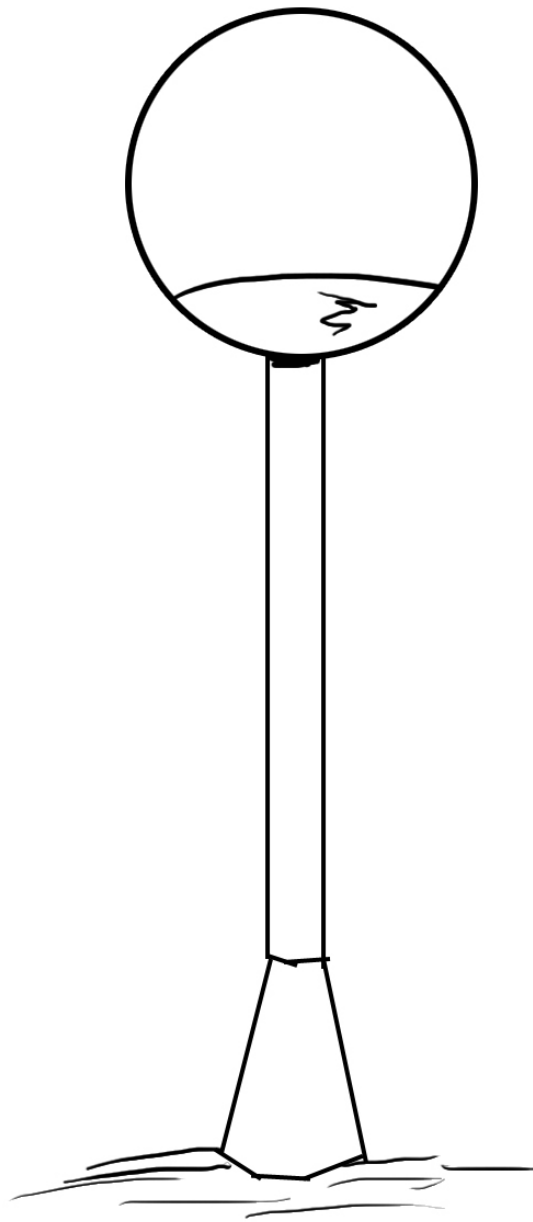

Farola

**FAROLA**

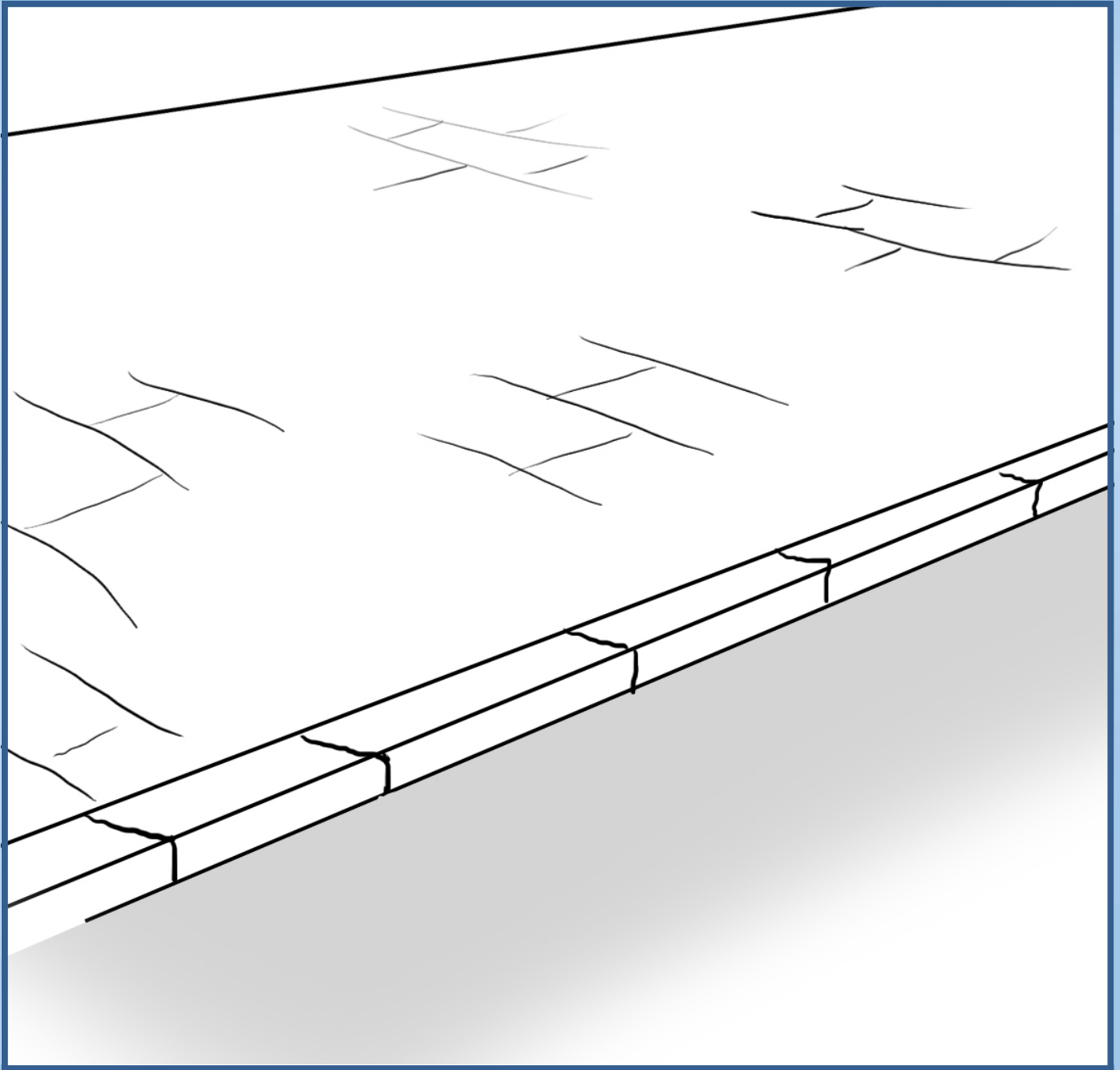

*Acera*

**ACERA**

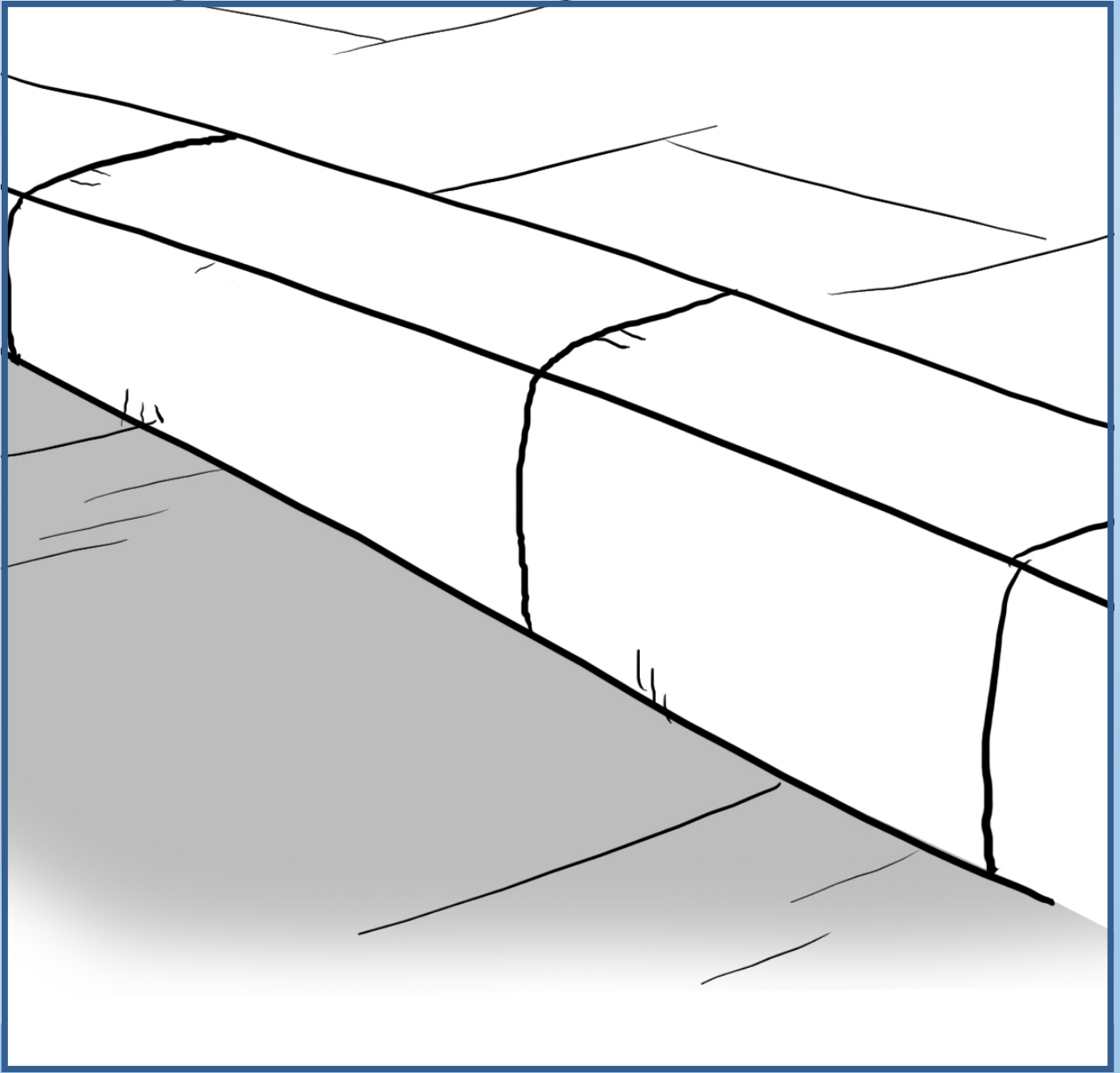

Bordillo  
**BORDILLO**

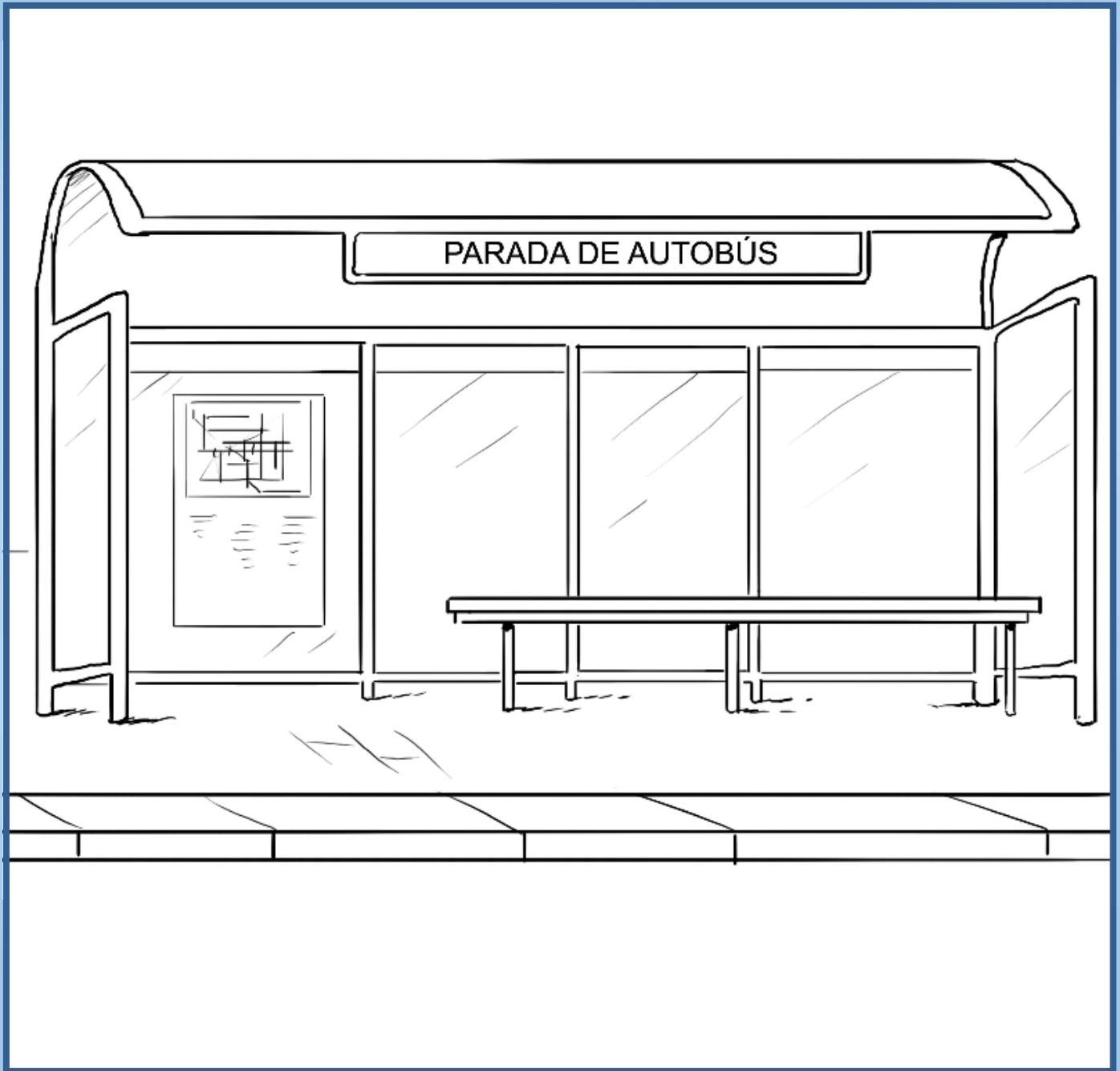

Parada de autobús  
**PARADA DE AUTOBÚS**



Papelerera  
**PAPELERA**



Recorta y pega en la siguiente página.

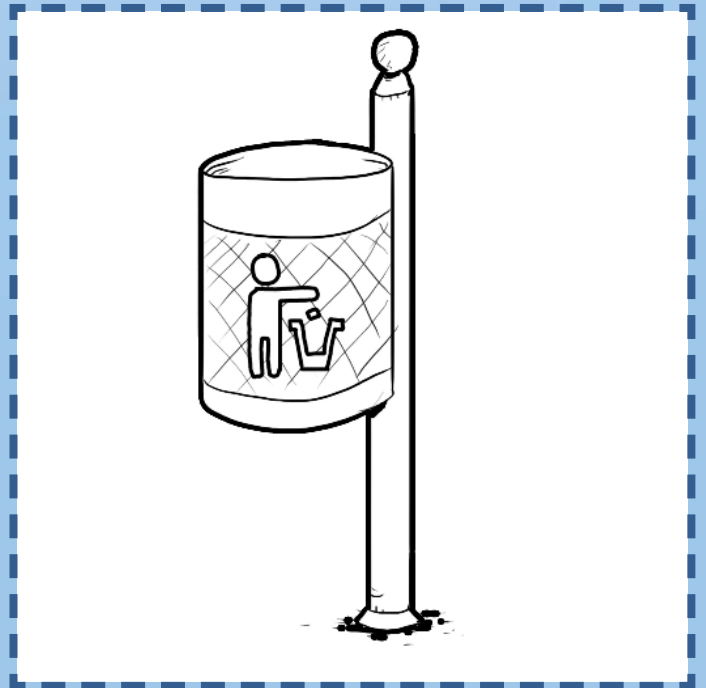
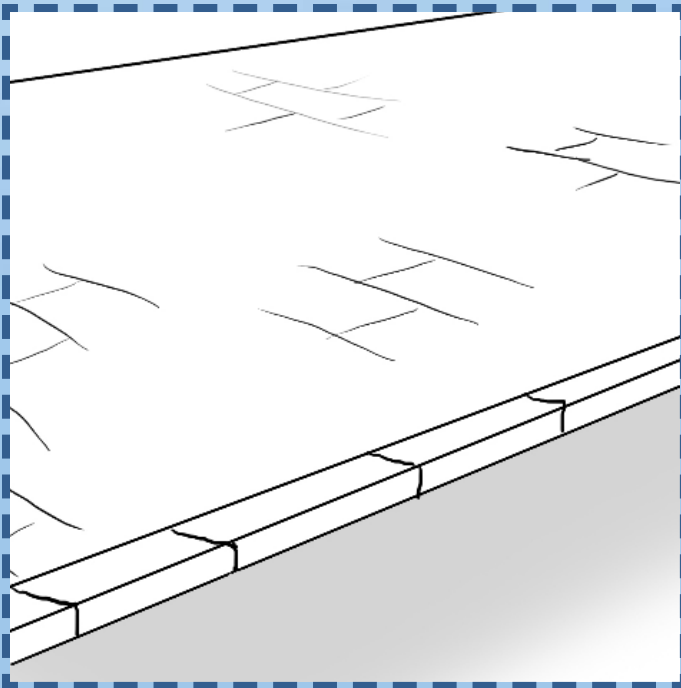
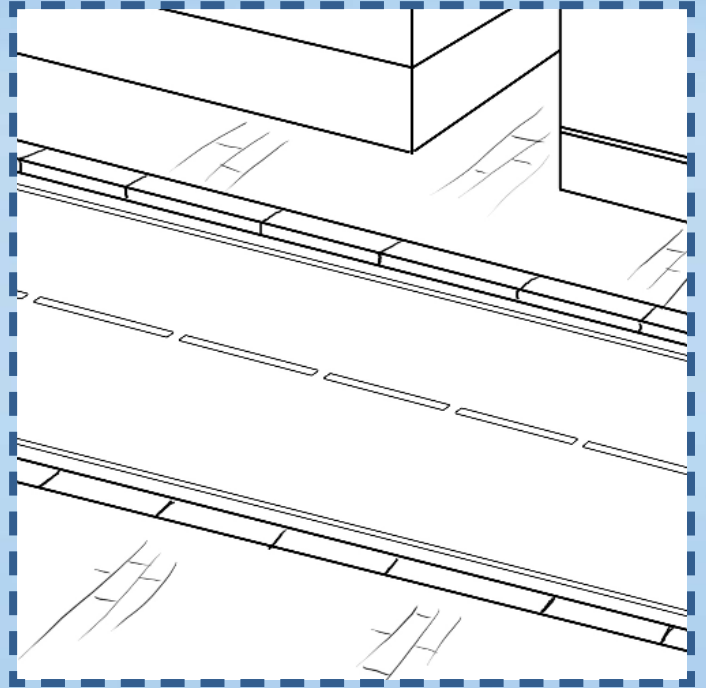
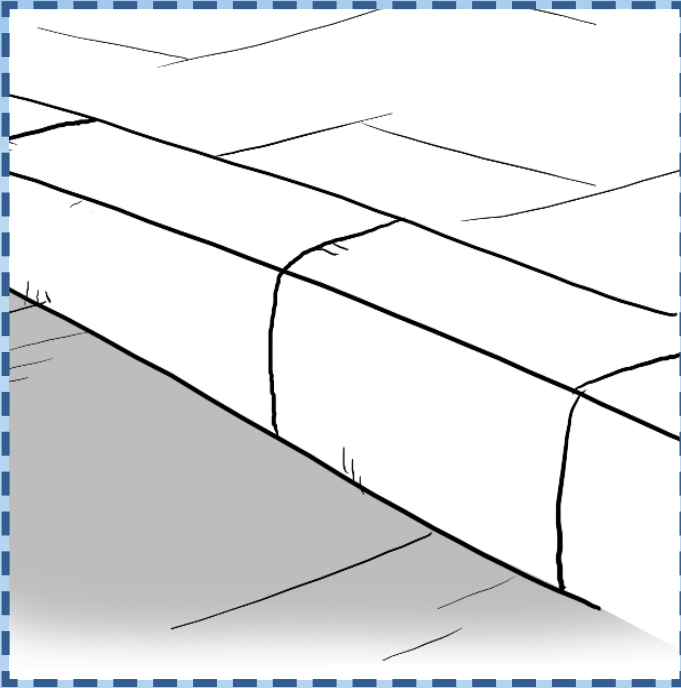

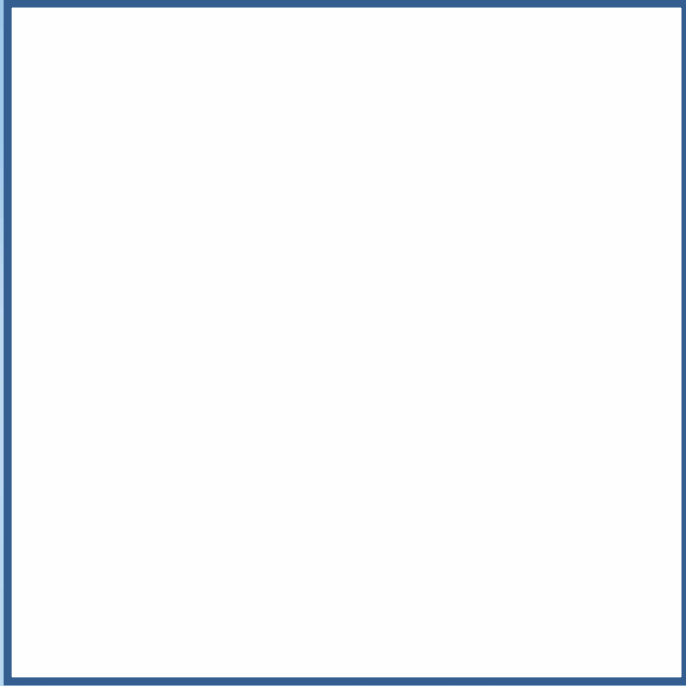

Papelera

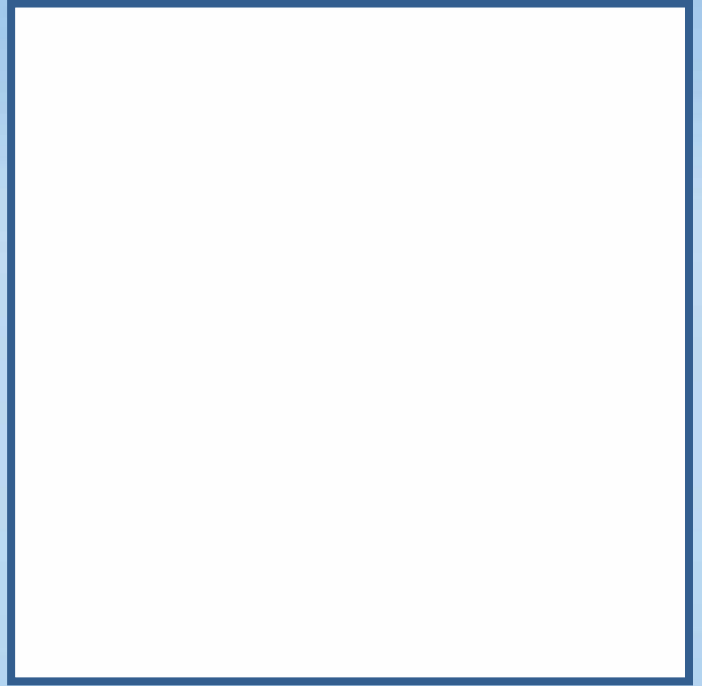

Acera

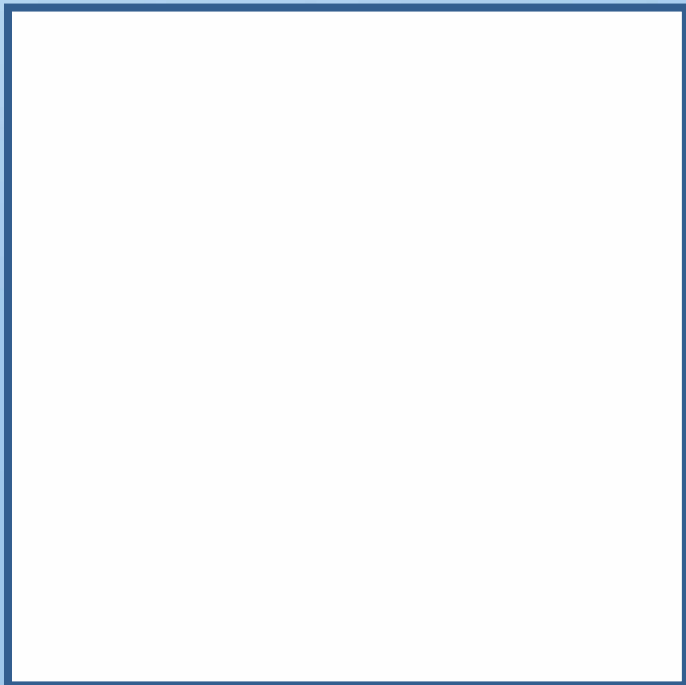

Bordillo

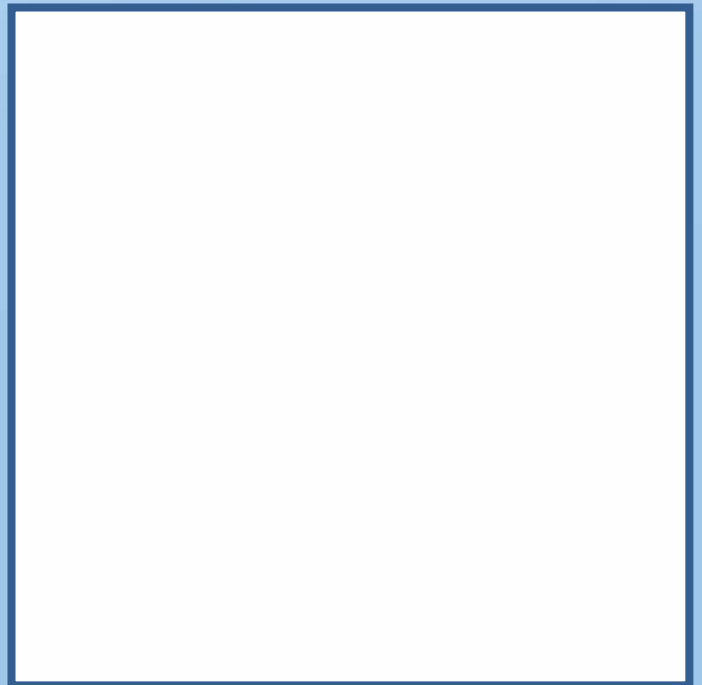

Calzada



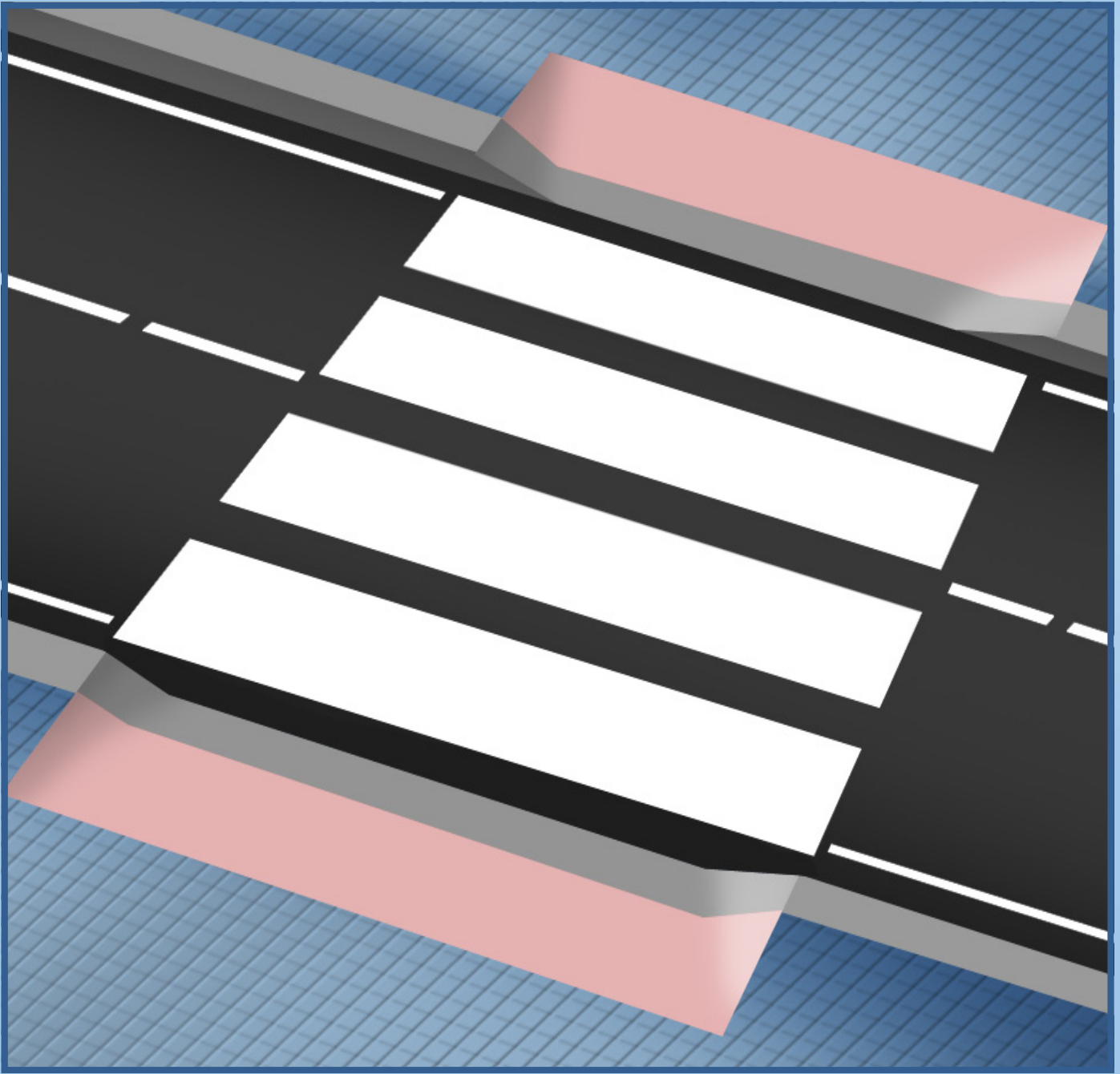

*Paso para peatones*  
**PASO PARA PEATONES**



Semáforo  
**SEMÁFORO**



*Paso superior para peatones*

**PASO SUPERIOR PARA PEATONES**

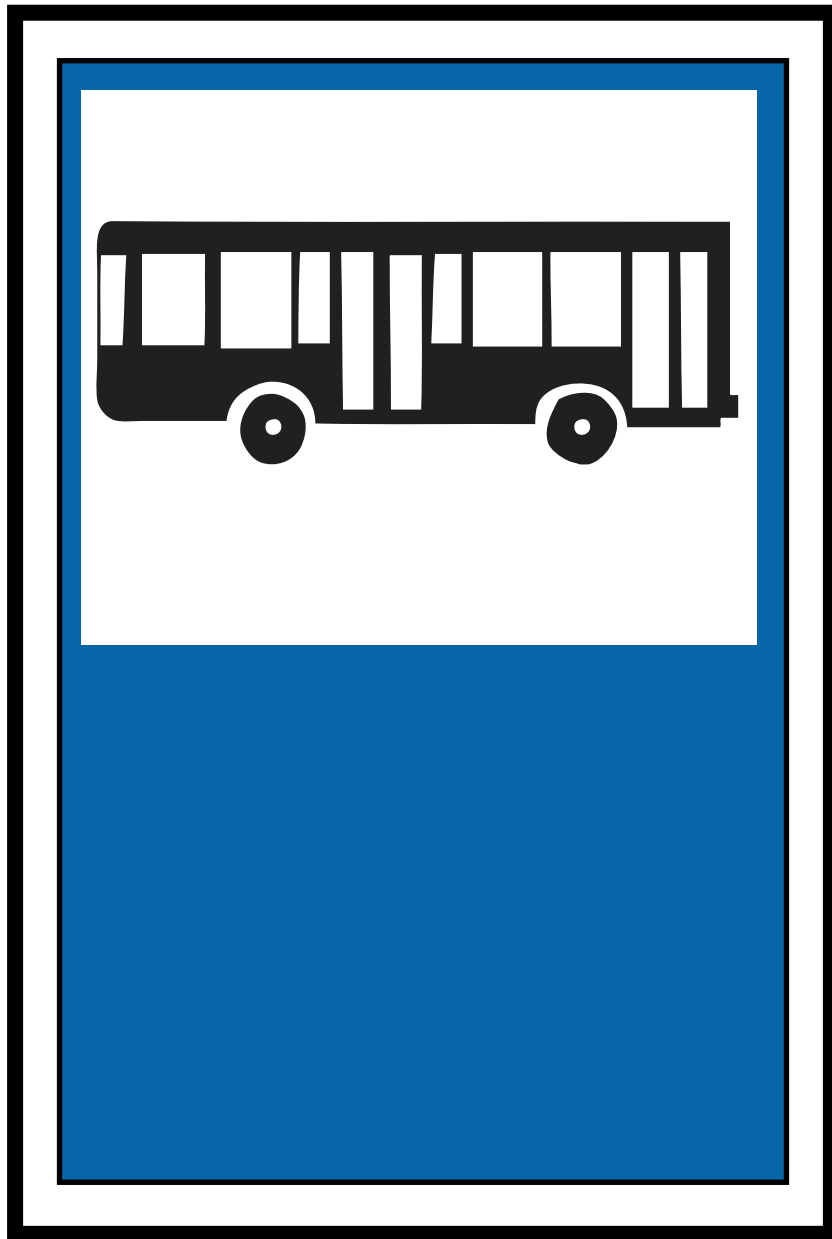

*Parada de autobuses*  
**PARADA DE AUTOBUSES**



*Entrada prohibida a peatones*

**ENTRADA PROHIBIDA A PEATONES**



*Camino reservado para peatones*

**CAMINO RESERVADO PARA PEATONES**



*Uso obligatorio  
del cinturón de seguridad*

**USO OBLIGATORIO DEL  
CINTURÓN DE SEGURIDAD**



Recorta y pega en la siguiente página.

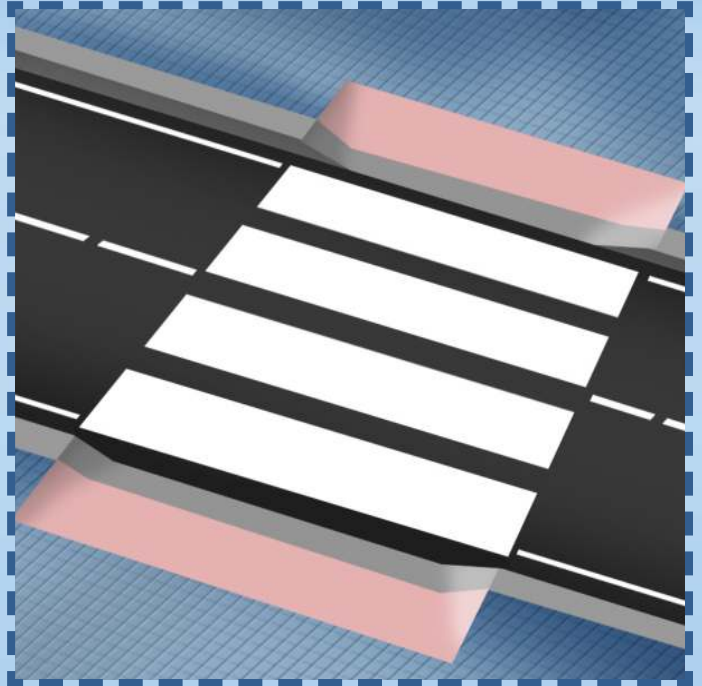



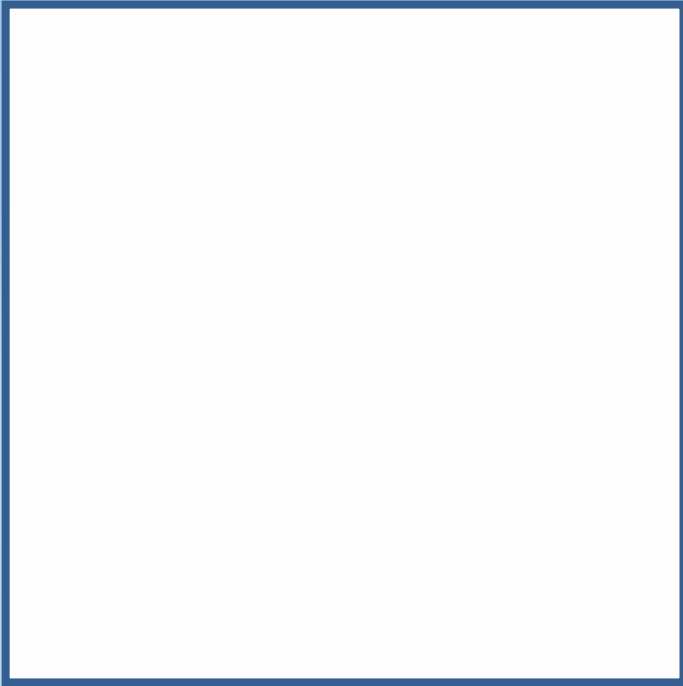

Paso para  
peatones

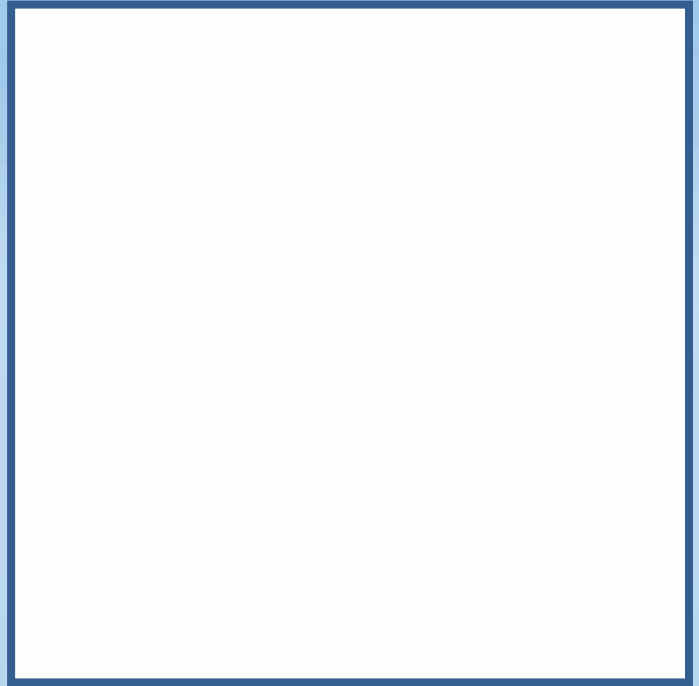

Entrada prohibida  
a peatones

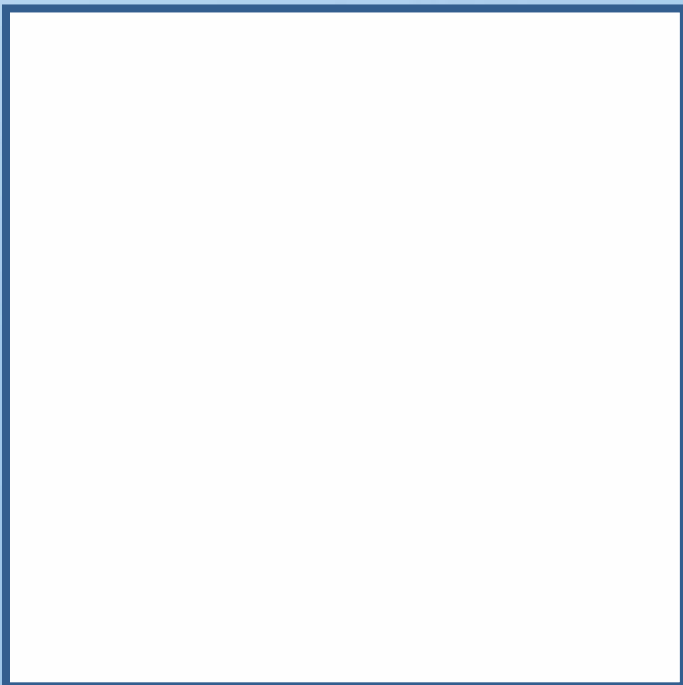

Semáforo

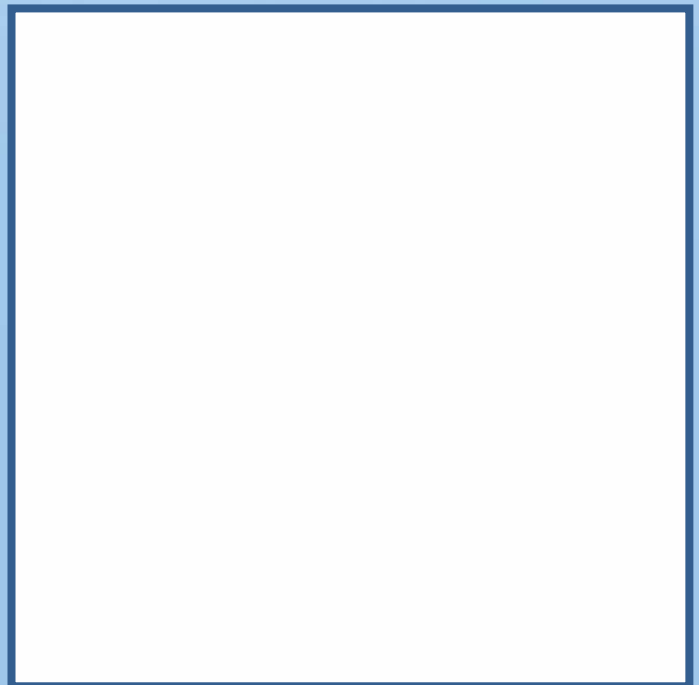

Paso superior  
para peatones



Recorta y une cada personaje con su vehículo.









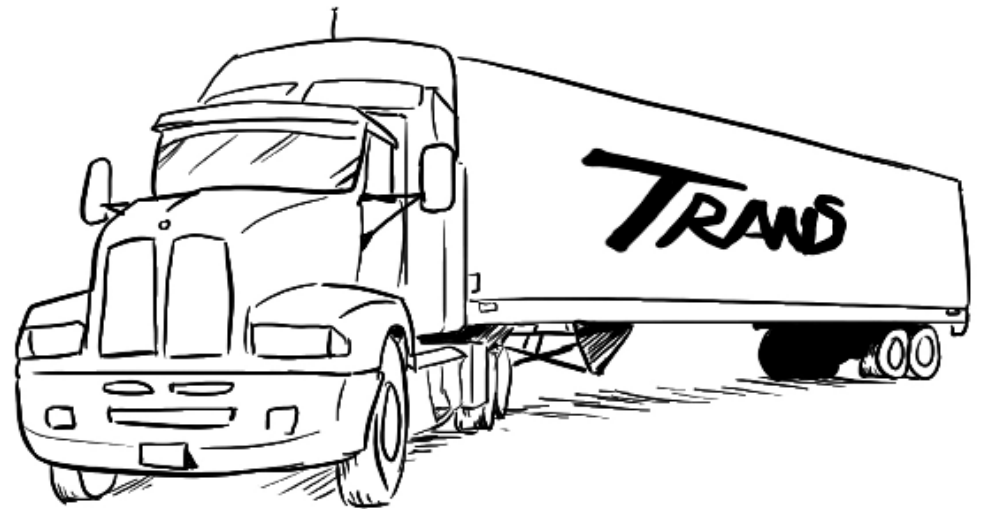
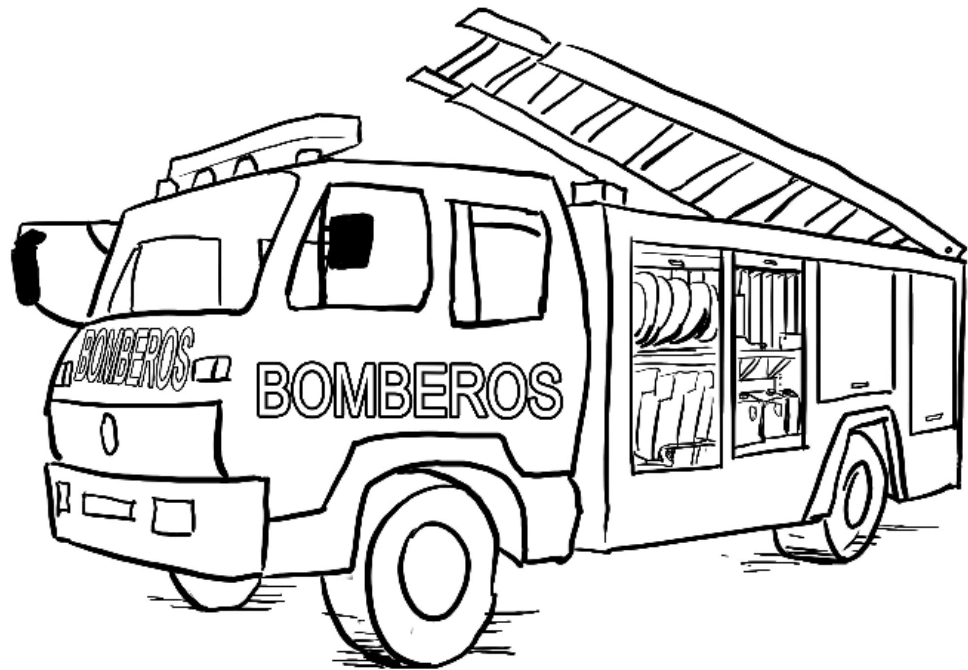

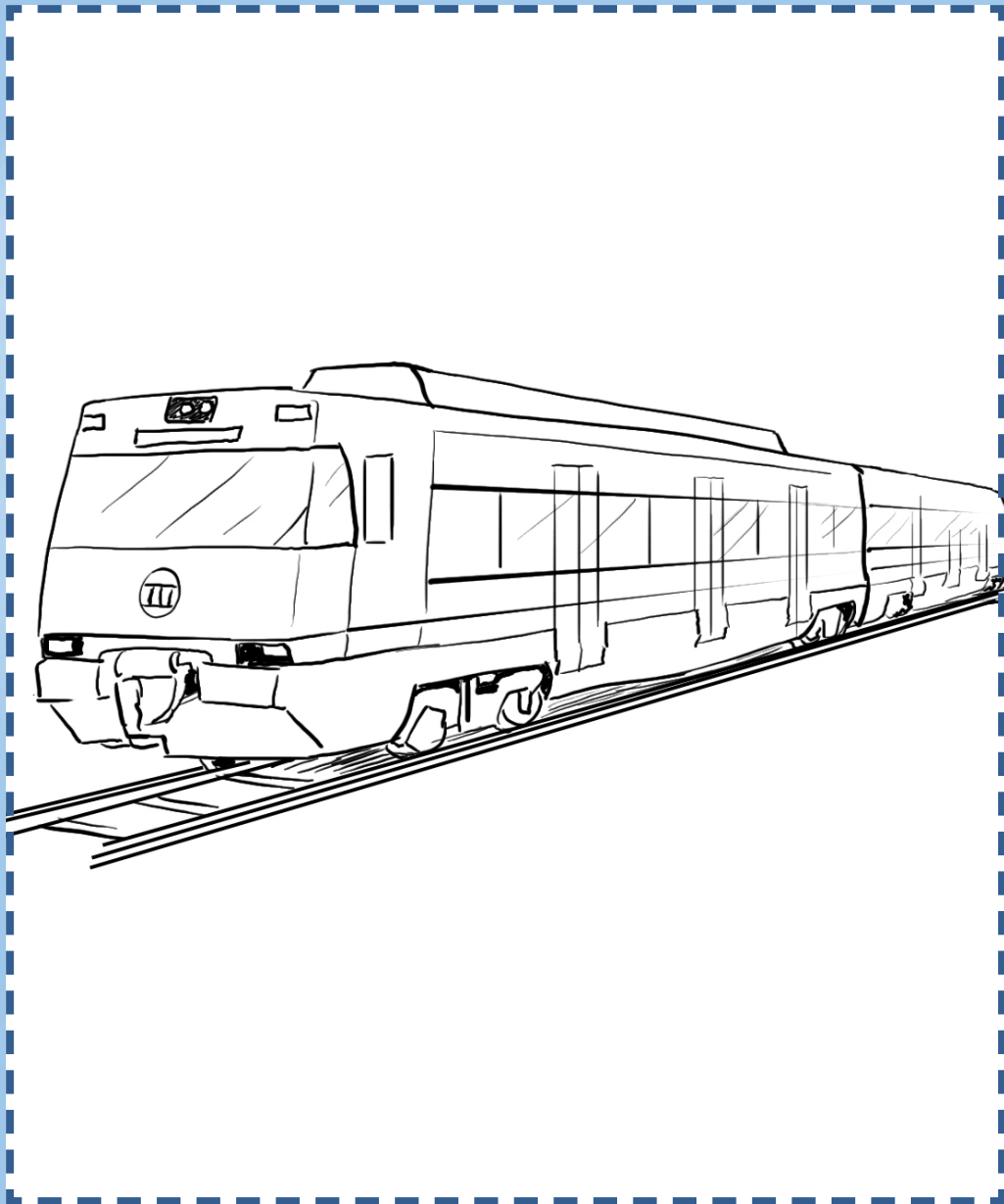

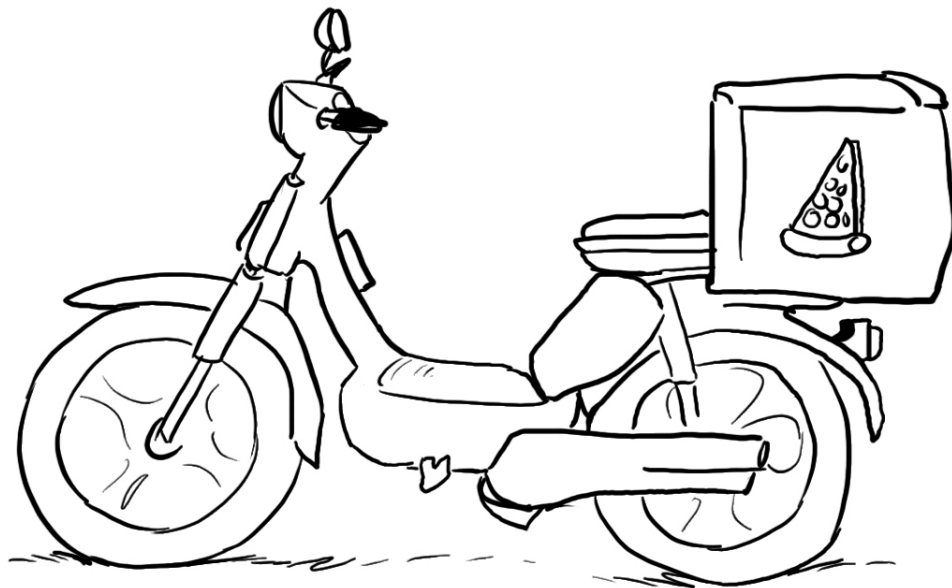
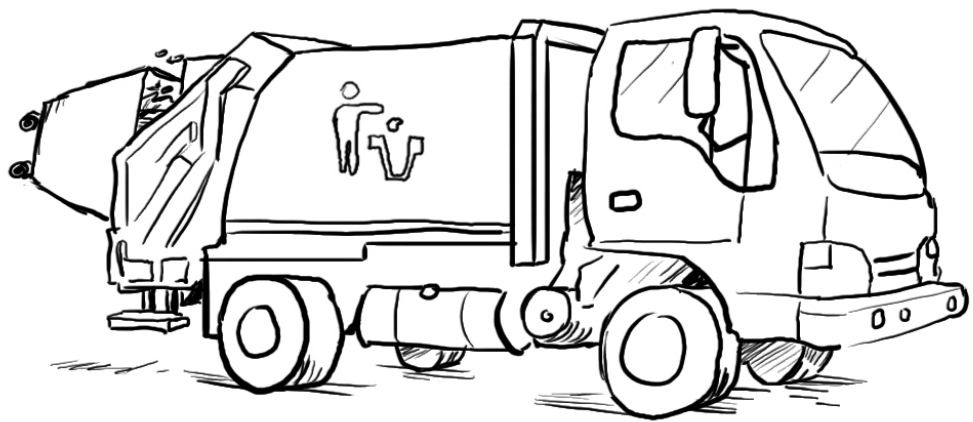



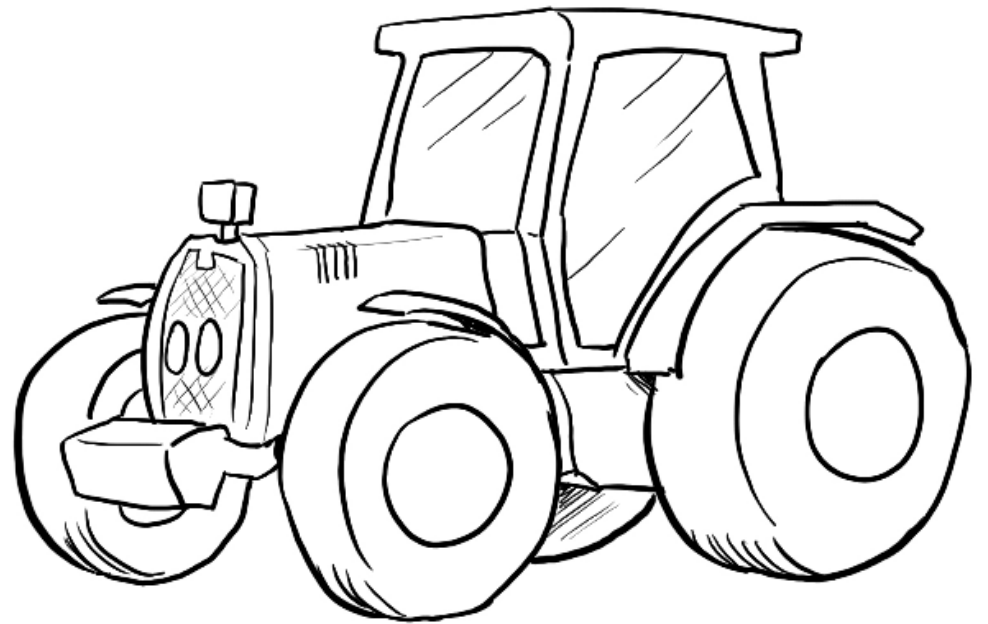
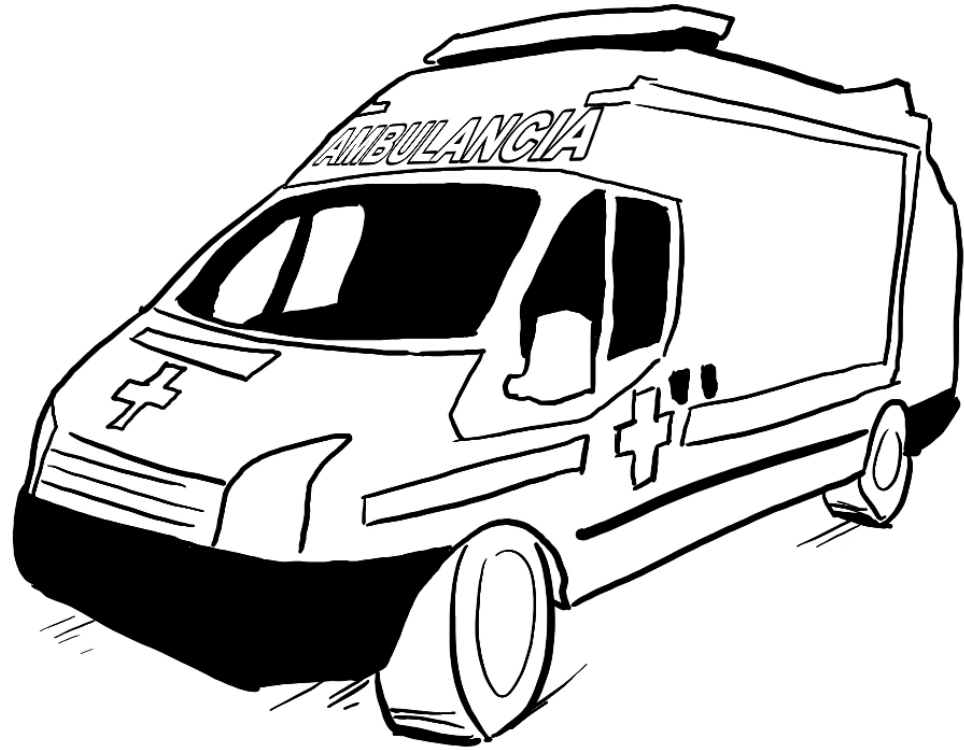

★ Pictogramas utilizados en las frases.



Niños



Caminar



Correr

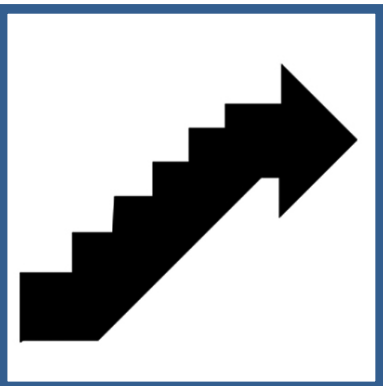

Subir

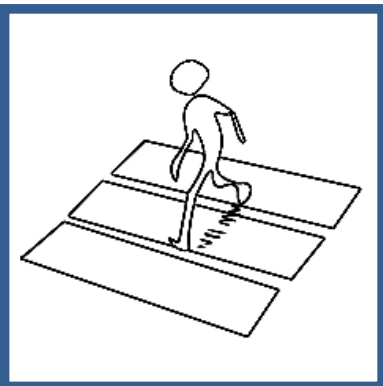

Cruzar

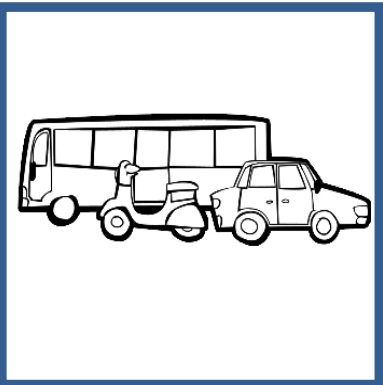

Vehículos

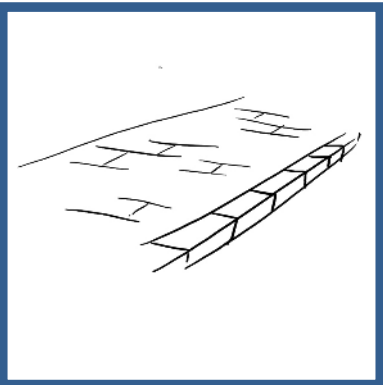

Acera

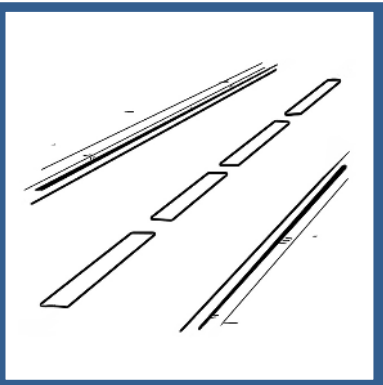

Calzada

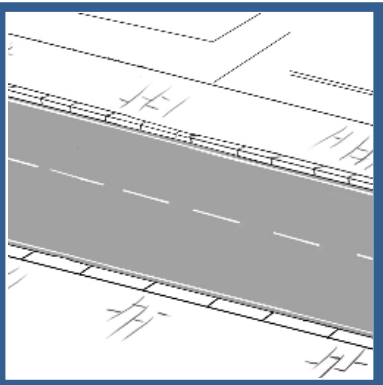

Calle

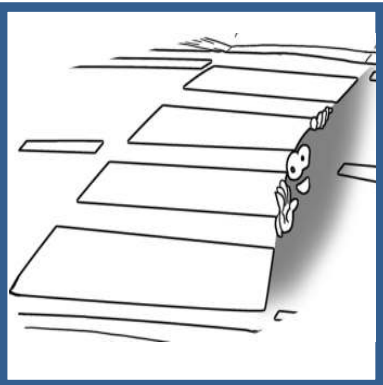

Paso para peatones



Escribe la frase completa interpretando los dibujos.







Escribe la frase completa interpretando los dibujos.

Un  sube a un 

---

Los  apagan un 



---

El   al 

---



Escribe la frase completa interpretando los dibujos.

La  lleva su  al 

---

El  y la  juegan en el 

---

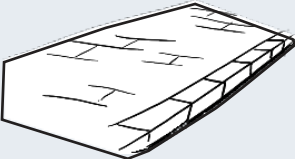
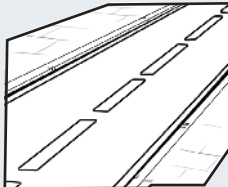
Los peatones  por la  alejados de la 

---



Escribe la frase completa interpretando los dibujos.

Los peatones no deben  ni  en la 

---

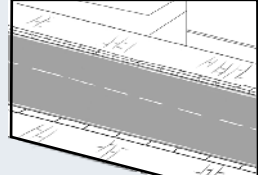
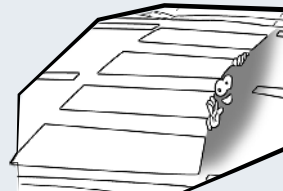
Los  cruzan la  por un 

---

El  ayuda a circular a  y 

---



Escribe la frase completa interpretando los dibujos.



cruzan la

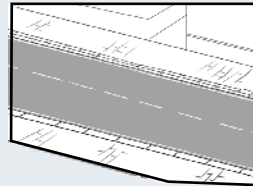

cuando el

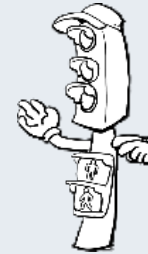

está en



---



en



no puedo

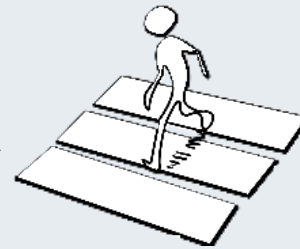

la

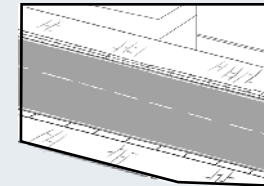

---



Lee la adivinanza y señala el objeto que corresponda.

3 colores en 1  
y no se repite ninguno.

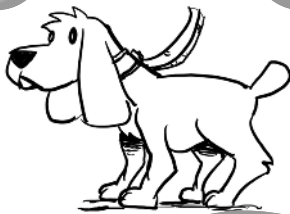



★ Lee la adivinanza y señala el objeto que corresponda.

Por el día y por la noche  
me lo pongo en el coche,  
y en caso de frenazo  
no me doy un porrazo.

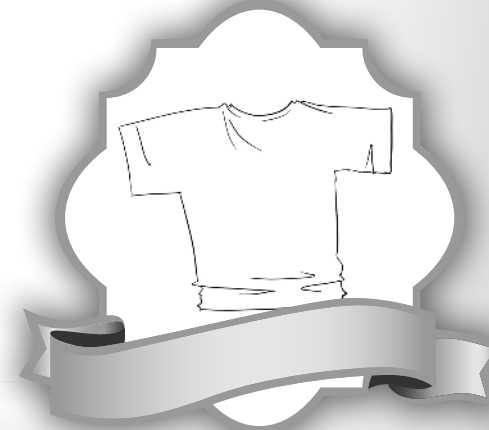
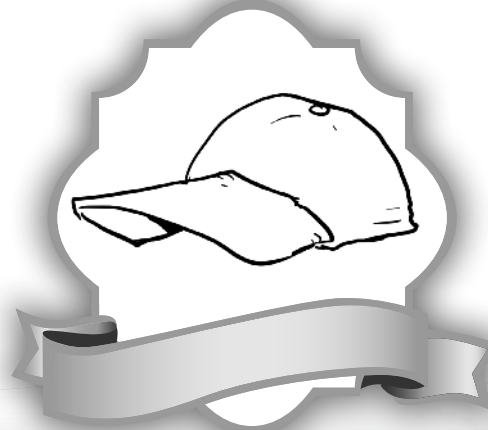
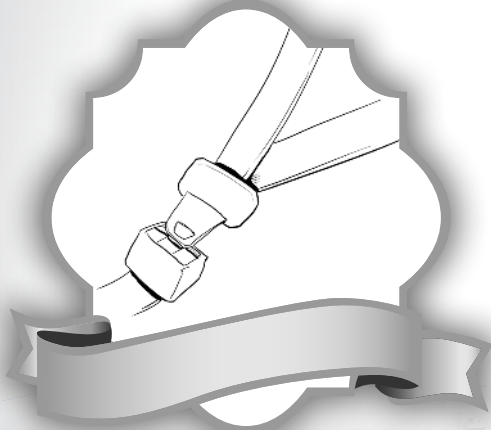

★ Lee la adivinanza y señala el objeto que corresponda.

En la calle me verás  
y al cruzar de un lado a otro,  
mis rayas pisarás.

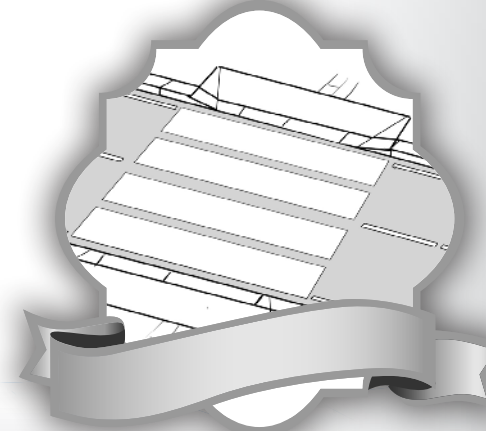
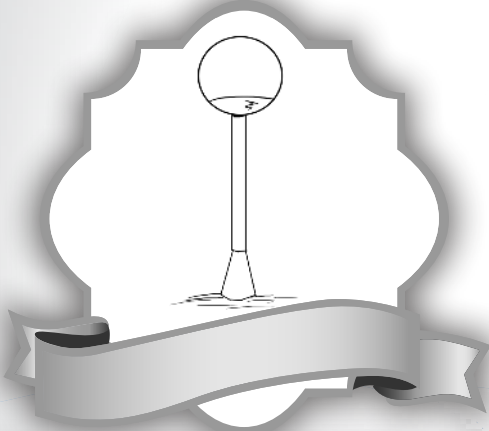

★ Lee la adivinanza y señala el objeto que corresponda.

2 pedales tengo  
que giran sin cesar,  
y a todas partes  
me llevan sin parar.

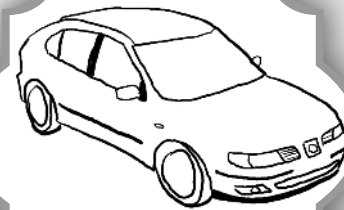
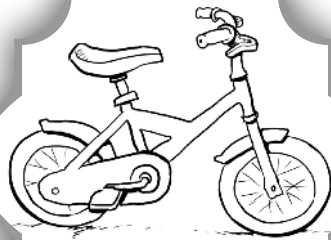



Lee y colorea la parte correcta.

¿Qué luces del semáforo se dirigen a los peatones?



¿Qué luces del semáforo se dirigen a los conductores?



★ Lee y colorea la parte correcta.

Un semáforo soy,  
si me ves así no cruces  
por aquí.



Un semáforo soy  
y ahora el paso te doy.





Lee y colorea la parte correcta.

Ten cuidado no debes pasar, cuando me veas de este color has de parar.

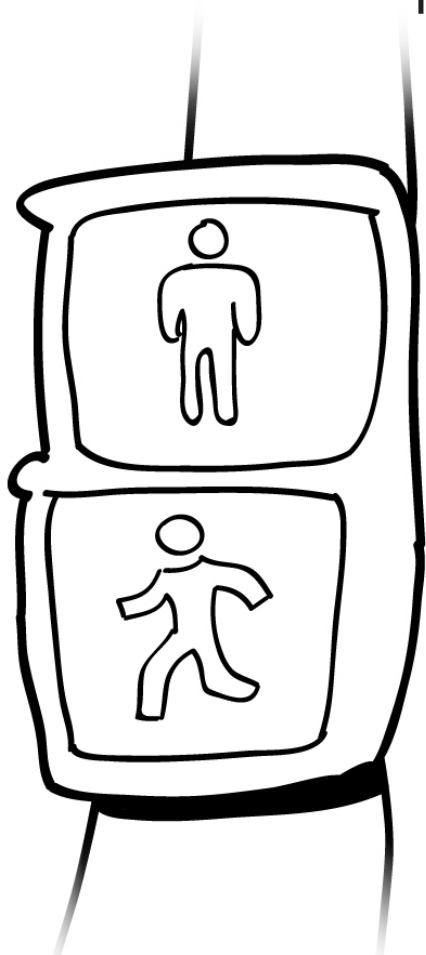

Si me ves de este color, cruza con precaución.

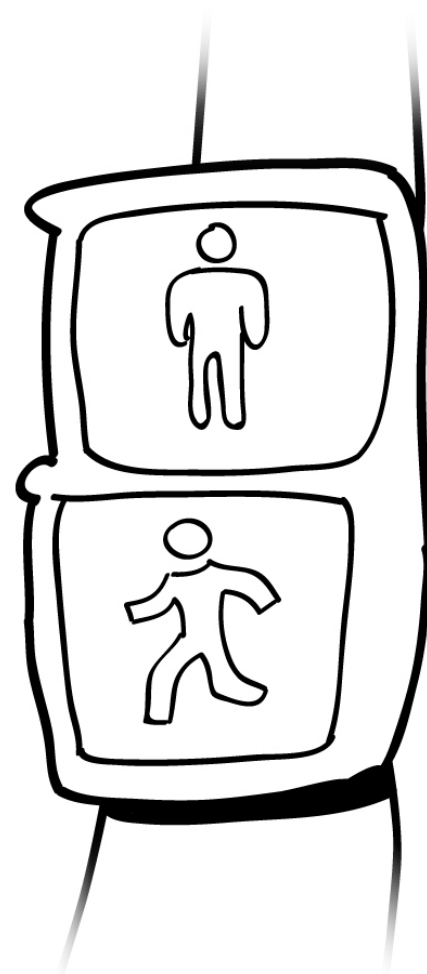

★ Recorta y pega las formas donde correspondan para completar la frase.

La señales de peligro tienen forma de \_\_\_\_\_

La señales de prohibición tienen forma de \_\_\_\_\_

La señales de indicación tienen forma de \_\_\_\_\_ o de \_\_\_\_\_

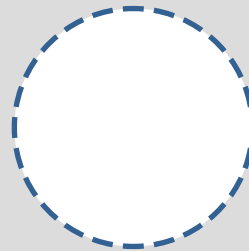
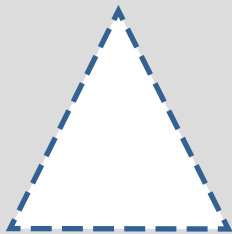

★ Lee y colorea la palabra correcta para cada frase.

1 Los coches y el resto de vehículos circulan por la

calzada

acera

cuneta

2 Los semáforos y pasos para peatones nos ayudan a cruzar la

bordillo

acera

calzada

3 Nosotros los peatones siempre circulamos por la

bordillo

acera

calzada



★ **Une cada frase con la ilustración correspondiente.**

Siempre subimos al coche desde el lado más cercano a la...

En el coche usamos los...

En el coche no molestamos al...

Cuando el coche circula nunca abrimos las...



¡Muy bien!  
Has completado todas las actividades.

Ahora no olvides todo  
lo que has aprendido, ponlo  
en práctica y demuestra  
siempre lo buen  
peatón que eres.

